

THE
INDIAN FORESTER;
A MONTHLY MAGAZINE
OF
FORESTRY,
AGRICULTURE, SHIKAR & TRAVEL

EDITED BY

J. S. GAMBLE, M.A., F. L. S.,

CONSERVATOR OF FORESTS, AND DIRECTOR OF THE
FOREST SCHOOL, DEHRA DÚN.

VOL. XVIII, 1892.

MUSSOORIE :

PRINTED BY THE MAFASILITE PRINTING WORKS
COMPANY, " LIMITED."

1892.

THE HISTORY OF THE CITY OF BOSTON FROM 1630 TO 1800

BY
JOHN H. COLEMAN
OF THE
BOSTON PUBLIC LIBRARY

THE HISTORY OF THE CITY OF BOSTON FROM 1630 TO 1800. BY JOHN H. COLEMAN, OF THE BOSTON PUBLIC LIBRARY. BOSTON: PUBLISHED BY THE BOSTON PUBLIC LIBRARY, 1891.

Index. 1892.

Vol.—XVIII.

I.—ORIGINAL ARTICLES AND TRANSLATIONS.—	Page.
A Tour through Kamraj-Kashmir, by J. C. McD.	1,41, 81, 127, 175
Sledge-Roads in France and in India—a letter from "Q" with translation, from the <i>Revue des Eaux et Forêts</i>	5
Practical Forest training grounds for the Coopers Hill College, by W.R. Fisher	12
An interesting new product	19
Leaf-fungus on <i>Ehretia serrata</i>	21
The Tortrix of the Teak tree, by J. N.	46
Famine and the forests of Bellary	48
Forest petitions in Ganjam	50
Kashmir products, by B. P.	51
The ferns of Pachmarhi and those of Mahendragiri, by J. S. Gamble	55
Obituary—Mr. F. C. Henvey	58
The Classification of Ants, by R. C. Wroughton	78
Thana Forests and their Working Plans, by G. P. Millett	89
The advantage of preliminary practical work in the training of Indian Forest Officers, by J. S. Gamble	96
Forest Settlements in India, by B.H. Baden- Powell, C. I. E.	182
Famine Work in the Madras Forests	148
The Stinging Tree, by J. S. G.	148
Village Forests, by Tserofski	150
The Germination of Teak, by S. C. Moss	178
The Double Coconut of the Seychelles Islands, translated from the ' <i>Revue Agricole</i> ' of Mauritius, by A. S.	181
Cutch and its adulterants, by F. J. Branthwaite	184,217
Obituary, A. J. Mein and W. E. D'Arcy	185
The Forests of Natal; being an account of the Report on them by H. G. Four- cade of the Cape Forest Service, by D. E. Hutchins	205,245

Timber carting in Surrey, by A. W. Lushington	214
Rate of growth of teak in the Magayee Plantations, Burma, by J. N.	218
A note on the Californian Poison oak, translated by S. E-W.	222
Christen's Patent Dendrometer, translated from the <i>Forst-und Jagd Zeitung</i>	254
The Extermination of Wild beasts in the Central Provinces, by P. H. C.	255
Note on Turpentine, by E. Thurston	261
Teak cultivation, by W. Buurman (translated)	285
Instruction in Forestry at Coopers Hill, by W. R. Fisher	292
Coorg and its timbers, by G. H. Foster	297,332
Useful Maxims for Tree-planting (translated)	303
The 'Local Trade' in Upper Burma, by J. N.	334
The qualities of good saws, by A. W. Lushington	337
Bürgermeister Krahe, by Sir D. Brandis, K. C. I. E.,	340
Cast Wood (translated from the <i>Révue des Eaux et Forêts</i>)	341
Forest Administration in the Central Provinces, by 'Tuscan.'	373
Durability of Railway Sleepers, by A. S.	379
Forest and Revenue Officers	379
On Pruning—translation from the ' <i>Révue des Eaux et Forêts</i> ', by A. F. G.	383
The Andamans, by E. M. B.	411
The condition of Forestry in New Zealand.	416
Tour of the Coopers Hill Students in France (Translation)	417
A great day at the Forest School at Nancy.	417
Grazing and commutation in the Central Provinces.	418
The Date Sugar Industry of Bengal, by Upendra Nath Kanjilal	451
Comparison between the Floras of the Eastern and Western Peninsulas of India, by Sir D. Brandis (translated by C. G. R.)	457
The Forest Service of Netherlands India	460
Visit of Spanish Foresters to the French Reboisement Works (from the <i>Révue des Eaux et Forêts</i>)	460

II.—CORRESPONDENCE.—

	<i>Page.</i>
A Hand seed-drill.	22
A Forest Department 'Blazer' ... 60, 186, 229, 306, 464	464
False quantities in botanical names	60
The Thana Working Plans,	61
The Coopers Hill Prospectus,	99
The Grass Farm at Allahabad	154
The formation of Dew	155, 226
Fires caused by Sparks	155, 186, 342
The Warrant of Precedence,	225
A plea for our feathered friends,	227
Range Officers in the Central Provinces,	263
The Mythology of Forest fires,	263
Occurrence of the Hamadryad in the North- West Himalaya	265
The seeding of bamboos.	304
Fires caused by bamboo friction,	305, 388, 432
Reproduction by extraction of stumps,	305
The appointment of Foresters,	307
Teak in Travancore,	385
Improvement in the Indian Raspberry by cultivation,	386
Note on the reproduction of Shisham,	387
Forest and other Civil Officers in Bombay	419
The Bombay Administrative Rules	423

III.—OFFICIAL PAPERS AND INTELLIGENCE.—

Bengal Arboriculture	23
Review of the Report of the Imperial Forest School for 1890-91	61
Articles on forest products for the Board of Trade Journal	63
Rules to regulate appointments and promo- tions in the Provincial Forest Service	101
Effects of the Cyclone of November 2nd 1891 on the forests of the Andamans	156
The Debra Dún Forest School, Distribu- tion of prizes and certificates	187
Forest products used in Soapmaking	189
The Forest Budget of 1892-93, extract from the Finance Minister's Statement	190
Budget Estimates of the Forest Dept. for 1891-92	191
Note on Lucerne cultivation, by J. Mollison	266
Wheat prospects in India for the year	269
Rules for the study of Forestry by Officers on furlough	310
Report on the physique of Junior Forest Officers	312
The New Edition of the Code	312

Report of the Board of Control of the Forest School, Dehra Dun	312
Fodder Reserves and Pastures	343
Sources of Rubber Supply	349
Good conduct badges	389
Budget Estimates of the Forest Depart- ment for 1892-93.	390
Forest Fellows of Coopers Hill	424
Joining arrangements for Forest Officers on first arrival	424
The re-organization of the Provincial and subordinate services	435
Note on the Potato disease in the Poona District	465
Pass marks at the Forest School Entrance Examination	469
Travelling Allowance of Foresters	469

IV.—REVIEWS.—

The Government Horticultural Gardens at Lucknow, 1890-91.	24
The Agri-Horticultural Gardens, Lahore, 1890-91	25
The Nagpore Experimental Farm, 1890-91.	25
Arboriculture in the Hyderabad Assigned Districts, 1890-91.	26
The Departments of Land Records and Agriculture in Bengal and Assam, 1890-91	27
Potato Culture—Mr F. W. Seer's Manual	27
Annual Report of the Botanical and Affores- tation Department in Hongkong for 1890...	64
Progress Report of Forest Administration in Jodhpur for 1890-91	65
Progress Report of Forest Conservancy in Ceylon for 1890	66
Indian Museum Notes Vol. II, parts 1 to 4	67
Report on the Department of Land Records and Agriculture, Burma, for 1890-91	68
Report on the Canal Plantations, N.-W P., for 1890	69
Report on Forest Conservancy in Victoria in 1890.	109
Descriptive List of the Timber trees of the Central Provinces of Ceylon	113
Forest Work in Baluchistan in 1890-91	114
The Central Provinces Forest Report for 1890-91	157
The Agricultural Bureau of South Australia	191
The Madras Forest Administration Report for 1890-91.	192, 471
"Inventions"	195
Administration Report on the Railways in India, for 1890-91	230
Raising Strawberries from seed,	232
The Berar Forest Report of 1890-91	232

Annual Forest Administration Reports of Bengal, Ajmere and the Andamans for 1890-91.	269
Annual Report of the Khandesh Experimental Farm for 1890-91.	272
The Scrub Exterminator	273
Annual Forest Administration Reports of the N.-W P. and Oudh and Coorg, for 1890-91	317
Number of species in the Java Flora	320
Manilla Hemp	320
Report on Forest Administration in the Jeypore State for 1891.	354
Effect of the time of felling on the production and development of coppice shoots	355, 391
Indian Meteorology	359
Vegetable cultivation in India	361
Annual progress Report of State Forest Administration in New South Wales for 1890.	395
Peach culture in Simla District	401
Report on the operations of the Department of Land Records and Agriculture, Madras, for 1890-91	434
Administration Report of the Railways in India for 1891-92	435
Forestry in South Australia	436
Botanical and Afforestation Department of Hongkong in 1892	470

V.—SHIKAR.—

Another last tiger, by S. E.-W.	70
Accident during the Garhwal Kheddas: The end of the rogue elephant	115
Destruction of a rogue elephant in the Dún, by Rajah Runbeer Singh	196
A tiger killed by buffaloes	198
A Man-eater, by E. D.	234
The Dehra Dún Fishing Association	274
A trip to Bara Bangahal, by F. O. L.	321, 437
Camp incidents in N. India, by O. C.	362
Hollow-fronted Bullets and large game, by O. C.	402
Forest School Sports, Dehra Dún	441
Extraordinary Capture of Wild Elephants, by H. B. Bryant	472
Dehra Dún Camp of Exercise	473

VI.—EXTRACTS, NOTES, AND QUERIES.—

Diseases of Conifers	29
Saltness of Coconut milk in the Sunderbuns	30
Grass-farming at Allahabad.	31
A Cannibal plant	35
'Tombak'	38
Collecting Mosses	72
The Indian Forest Service and its founders	73
Casuarinas	76
Forest of Box	76
A curious find in a Walnut Tree	76
Utilization of cut Grass in Reserves	77
Elephant-catching operations	77
The Forests of India and their products	118
Kamila dye in Ganjam	122
Indian Gutta Percha	122
The new Professor of Forestry at Edinburgh	123
Change of Editorship of the <i>Révue des</i> <i>Eaux et Forêts</i>	123
The Forest Department List	123
Effects of parasites on trees	124
Portraits of Forest Officers for the Nancy Collection	159
The Economic importance of birds in India, by W. L. Sclater	160
A new method of sawing planks	164
Forestry in Ireland	164
Death of Mr. John Macgregor of Dunkeld	165
Padouk wood in England	166
Deterioration of Scotch Fir	166
The European C. S. Association	172
Growth of planted trees in Assam	198
Aloe fibre	199
Eucalyptus Oil	201
The Teak trade of the Laos States	203
The comparative value of various fuels	236
The pencil cedar industry	238
Creosoting sleepers	239
Is it good to dig about trees ?	240
Olive oil in the South of France	241
Forestry Lectures in Edinburgh Univer- sity— <i>Session 1891-92.</i>	243
Seeding of Bamboos	244
The Oak	275
Goats in the Bombay Presidency	275
Match manufacture in Japan	276
The preservation of logs	277
The influence of Forests on Water-supply	277
Alaskan Forests	280
Report on the Timber trade of Bosnia and the Herzegovina	323

A Burmese Axe-head Wood	327
How nutmegs are grown	328
The new head of the Woods and Forests			
Department of the Cape	329
Dew, and its action on plants	364
Forest destruction and the Russian famine	366
Seeds of Sugar-maple	366
Match manufacture in India	367
State Forestry in America	367
The largest band saw machine ever made	367
White Wax in China	468
The Coopers Hill Prize day	404
A serious grievance	405
Wattle bark for tanning	405
A Tea-Estate pest in the Dún	406
A corner in "Nuns."	407
State Forestry in America	407
The Brandis Prize	408
On Judicious Pruning...	443
The history of a Railway Sleeper	446
A new method of preserving potatoes	474
Barré and the discovery of the Coco-de-mer	474
Pruning in Parks and Gardens	477
New appointment of Col. Bailey, R. E.	479
Wood Concrete	480

VII.—TIMBER AND PRODUCE TRADE.—

Churchill and Sim's Wood Circular	40, 79, 126, 172, 245	
	284, 371, 408, 449, 482	
London Produce Sales	...	40, 173
Selling rates of timber in the N.-W. Provinces		
	125, 204, 330, 481	
The Teak Market in the first quarter of		
1892	...	282
Market rates for products	...	284, 331, 409, 450, 482

VIII.—EXTRACTS FROM OFFICIAL GAZETTES.

SUPPLEMENTS.—

APPENDIX SERIES.

- (1) Padauk Wood.
- (2) Podophyllum.
- " Lac."

Indian Woods for Tea Boxes.

Report on the Sea-borne Trade in the Timbers of Burmah.

Forestry

SD

I 398

THE INDIAN FORESTER.

Vol. XVIII]

January, 1892.

[No. 1.

A Tour through Kamraj—Kashmir.

After a month spent in Srinagar during which I had been endeavouring to make myself acquainted with the present state of affairs in forest matters, I was at length able to leave for my first tour in the forests. The Kamraj District was chosen to start with, as it contains the famous Lolab and Utr Machhipura valleys in which were said to lie the best forests. These valleys are situated to the N. W. of Srinagar and the easiest way to reach them is to drop down the river in boats, known as *dongas* to Sopor (Shivpur) or some point near and march from there. I did not take this latter route, as I wished to see all the forests in the District. The *donga* requires merely a brief description; it is a long, narrow and shallow flat-bottomed craft with bow and stern slanting upwards from the main hull, both being narrowed to a point. A frame work of light poles is fitted on the hull and on this mats are placed to form roof and side walls. The whole can be lifted out and the sides rolled up. The traveller occupies nearly the whole of the hull, a small space being left at the stern for the boatmen and his family, in which there is invariably at least one baby in the crying stage! Another such craft is hired for the servants and luggage and then the traveller is equipped for Kashmir boat life. Having arranged all this we left Srinagar very early one morning at the end of July; we floated slowly down the Jhelum enjoying the lovely air and scenery, past the Munshi Bagh where dwell the Europeans, and past the shops where the said Europeans are supplied with canned goods as our friends the Yanks call them, more or less fresh at more or less exorbitant prices. Then the Lal Mandi comes in sight, a handsome building seen from a distance, but one that will not bear close inspection; the rooms are fine and well suited for the entertainments for which the building was erected, but the decorations on the walls and the coloured glass globes are not of a high order of art. Next we leave behind the state Hospital and passing under the Amira Kadal or principal bridge, the State Council House and Palaces come in sight. The bridge is a wonderful structure on

the cantilever principle, too well known to need description. It is amazing how long it has lasted and the builders of old evidently knew or did their work much better than their modern brethren, for while the Amira Kadal has stood for many a long year and looks as if it would never get any more rickety than it is at present, two new bridges made last year over the river, near Islamabad have both been carried away by a flood which swept down during August and simply floated them away. The new palaces are to be of modern European architecture and will be substantial, handsome buildings, but will take a long time to complete, judging from the present rate of construction. Raja Sir Amar Singh, the President of Council, has built a very handsome little summer house for himself, just below the palaces, but here also there are grass green tubs and marble top tables in the garden which somewhat jar upon one's nerves. After the palaces, comes chaos, otherwise the dirtiest, smelliest, most tumble-down city in the world, reminding one of the pictures of Old London Bridge in one of Harrison Ainsworth's novels. About midway down is the principal ghat which leads to a square called Maharajgunj; here dwell the persuasive silver, copper, and shawl merchants. A warning must be given against any one going here to buy, it is far better to get the name of a good man and let him bring his wares to the house. The silver-work is beautiful, the pattern most appreciated being the lotus flower. These men must do a great trade judging from the orders in their books; and here, be it noted, that Kashmir is, above all, the country for chits, every one from the Thasildar down to the lowest boatman asks for a *razinama*; and a mighty pest it is, especially so when, as happened to me, one is given saying everything had been beautifully arranged, only for us to find it the very reverse after we had started, but still the certificate remains to be shown to others. The copper-work next demands attention, the work is most artistic where they have kept to Oriental patterns; when new, a copper tray is a thing of beauty but it very soon tarnishes and though the merchants say it can easily be cleaned, the general verdict is that it cannot be done satisfactorily. After Maharajgunj more dirt, smells and tumble down houses as we drift slowly down the busy river studded with boats of all kinds from the tiny *shikari*, holding one or two people, the *donga* for travelling, up to the huge *kishti kalan* capable of containing many hundreds of maunds of *shali* (paddy,) with a house at the stern in which the boatman and his family are born, grow up and die, for they are entirely a floating population and possess no home on land. They have a hard life these boatmen, their food being apparently rice of a poor description and Singhara nut, but still they are a fine strong race and as far as one can see through the dirt, not bad looking. Like most Kashmiris they are very unmanly and a huge male creature will break out into the most womanly shriekings on a very small provocation.

At last we leave the city behind and emerge into a flat unlovely country only redeemed here and there by a beautiful grove of chinar trees. One hears boat life very differently spoken of, some praise it as the most luxurious life possible, others say the very reverse, my experience inclines me to the latter view. To begin with, the boat swarms with fleas so that a liberal supply of insect powder is indispensable if any rest is to be expected at night. Then there is hardly room to move about and to wind up with, the boatman and his family live at the stern and when they want to cook their food the traveller is simply smoked out. In the day time if the weather is fine it is indeed most pleasant, but it soon gets terribly hot especially on the Wular Lake; and towards sunset, life is made a burden to the traveller by the myriads of ferocious mosquitoes which pursue him as long as he is on or near the lake. So we float along till we cross the Wular Lake and make Sopor, a great fishing resort, but not an inviting looking town to stay at; we pass rapidly under the bridge and urge the men to work hard as night is approaching and our destination is Duabgah, vulgarly known as Dobgam, a few miles below Sopor, this being the great firewood and timber depôt for the forests below Srinagar. It is dark when we arrive and as it has been raining, the ground is a swamp and we experience an hours misery while the tents are being put up, for cooking is going on in the boat and the mosquitoes swarm outside; not at all a nice place is Duabgah at the end of July after a heavy fall of rain. We are up betimes next morning after a cool night, which we spent in the boat, made lively by fleas, and mosquitoes. I then take a survey of the first Kashmir timber depôt which I have seen and luckily no expectations of order or regularity had been formed, so there was no disappointment. The old lines "The British fleet thou canst not see for 'tis not yet in sight," came to my mind for the depôt proper contained no timber, that was all lying in the Pohru river which joins the Jhelum at this place; nor is it ever taken out and landed here, but without being numbered or registered is taken on in boats or rafts to Srinagar. What the depôt contained was a sight not to be seen in the Punjab, *viz.*, thousands of short logs of deodar, kail (called kairu here) *tos* (*ré*), *rai* (*budlu*) standing on end and closely packed together, ranging from 4 to 7 feet in length. This is not used for building purposes but for firewood, and an enormous quantity of it is yearly consumed in the city. The old system was that the *hanjis*, that is boatmen, simply went into the nearest forest, cut what they liked, brought it to the waterway and then conveyed it to this depôt. Here the weight was estimated, then the state share, one fourth, deducted in kind; the balance remaining the property of the *hanjis* who took it into Srinagar for sale. The one fourth state property was also taken to the city and sold for the benefit of the state government. There is also another method in which all the timber is state property, the *hanjis* cut in the

forests and bring to this depôt and are paid at a fixed rate of so many *Kharwars* per rupee (a *Kharwar* is some seers over two British maunds) this too was estimated and the boatmen knowing that they were to take it into the city afterwards and sell it for the State, used to understate the quantity and sell the excess on the road. In fact, arrangements in the past have been what might be expected under the circumstances. The boatmen will now be initiated into the mysteries of cubic measurement. The deodar logs are of excellent quality and should never have been cut in such short lengths; in Jhelum they will sell for more than four times what they would fetch as firewood in Srinagar; they will now be launched and sent down to the plains together with some hundreds of the best kail logs. In this depôt were found a couple of thousand broad-gauge sleepers cut some twenty years ago and nothing done with them! As very many of them were in good condition, all have been launched for Jhelum; the highest price obtainable here was $4\frac{1}{2}$ annas and they can easily be sold for perhaps 12 annas to Re. 1 each below. The next thing to look at was the timber in the river and it was astonishing to find that the greater part of it consisted of long poles under 3 feet in girth, hardly ten per cent being really logs. This of course could only mean that young trees were being felled and such was found to be the case when the forests were examined; a most lamentable waste of timber. This is all taken in to Srinagar for sale; there are some 30 different names for this timber, not the simple classes of British depôts. Thus a *Shahtir Kalan* is a round piece of timber about 35 inch long by 36 inches girth; *Shahtir rasami* 30 feet long and 30 inch girth; *Shahtir nim* 27 feet long 30 inch girth and so on. Here can also be seen some of the enormous *Takhta* used in boat building, they run to 70 feet in length by perhaps 3 feet in breadth and 4 inches thick, two of these are cut out of one tree. The men use axes for this purpose, long and thin, they cut as deeply as they can down the length of the log till they reach the centre, then turn it over and repeat the process till the cuts meet; the outside slabs are hacked off in the same way and the *Takhta* cleaned with an adze. After this it has to be dragged with much labour from the forest to the water way. This boat building question is a most serious one, for the number of boats plying on the river and lake is prodigious and what the people will do when they are no longer allowed to cut first class trees into planks it is difficult to say. They do not understand the use of the saw and even if they did, the cost of building a boat of sawn planks would be very high compared with the present method, but change they must for the forests cannot now contain many large trees, seeing that unrestricted fellings have been going on for generations past, and those that are left must be most carefully dealt with.

J. C. Mc D.

(To be continued.)

Sledge roads in France and in India.

DEAR SIR,

I send you a translation of a paper on Sledge Roads by M. Jolly in a late number of the "Revue des Eaux et Forêts," because it seems to me to contain many points of great value to an Indian Forester. So far, in India, the cost of labour being so low has restricted sledge road construction to main arteries and that being so it has been found advisable to build them strongly while about it. I cannot but think, however, that experience would shew that we might with advantage proceed a step further—though not so far as in France—and make sledge lines down accessory valleys of moderate size that it will take, say three years, to work through. And it should be recollected that the mere saving in money is by no means all the advantage to be had from such export works—there is the saving in time, a great consideration, and comparative independence of the coolie supply market (often also of considerable moment in distant parts). I believe a great deal more may be made of the forest means of transport so long in use in Europe (especially in obscure corners of Europe, where labour is probably cheap) than is made, though at the same time it is certainly exceedingly essential to recollect the strong tendency a keen forester feels to go in for "jims" of the kind. He may throw a lot of money away, but then again he may introduce a means of immense economy, I think the larger sum is more likely to be on the side of the economy.

"Q."

TRANSLATION OF A PAPER ON "SLEDGE ROADS"
BY M. JOLLY

in the "REVUE DES EAUX ET FORETS" of the 10th March, 1891.

In mountains more than elsewhere, means of export constitute one of the chief factors in estimating the value of woodlands. The works undertaken in order to improve these means of export in the Government forest charge of Senones aim at reducing the cost of transport and maintenance not by means of a perfected system, but in the rational use of the old methods of the country.

These forests, of which the altitude varies from 340 to 930 metres (about 1,100 to 3,000 feet) form a block of 5,171 hectares (13,020 acres) situated on the Vosges Sandstone. The rock is not good metalling and the maintenance of metallated roads is consequently very expensive. Trap, only found in distant quarries, does not cost less than 10 francs the cubic metre on an average. Consequently, the forest roads scarcely penetrate except into the main valleys. In the secondary valleys, carts go over the natural surface: the smallest cart road would necessitate exaggerated expense both for construction and maintenance.

How then are we to ensure satisfactory communication at small cost, from the fellings to the pukka roads? After making experiments, the most practical plan has been found to be Sledge Roads.

As we know, what has to be done is to load up the wood on the sledges, which men guide, augmenting or moderating the rate of speed according to circumstances. These sledges, which are built to carry relatively large loads, are made of very well-seasoned beech by the sledgemen themselves, the component parts being fixed together by trenails. They can carry all kinds of material: logs, planks, scantling or fuel.

The logs intended for sawing are converted, some to order, others, according to the ancient usage of the Vosges, into lengths of 4 metres (just over 13 feet). The latter are sledged in the "bouc" sledge or the "large sledge." The "bouc" (fig. 1) is short and only carries one end of the log* which is first slightly notched so as to catch on to the sledge properly. It is fixed in firmly with a chain finishing in an iron wedge driven into the bark.†

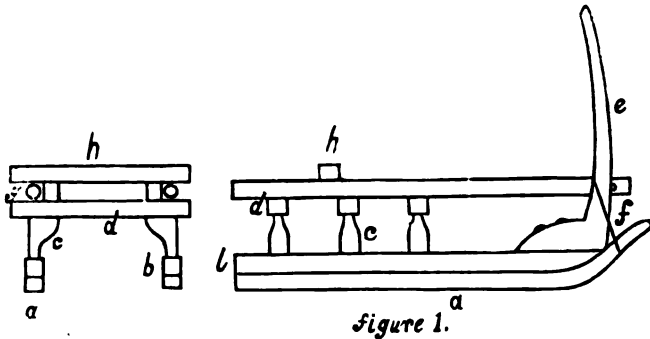

The average load of a "bouc" is about 40 planks. To bring very large logs containing perhaps 60 to 80 planks, several men are often employed directing the "bouc."

One can in this way negotiate slopes varying from 50° to 20° ; since the "bouc" only carries one end of the log while the other end drags on the ground, which gives considerable friction. Towards 20° it becomes necessary, in order to make the sliding easier, to cover the soil with small branches and twigs.

*—*a*.—Sole; *b*.—runner; *c*.—log; *d*.—transverse; *e*.—handle; *f*.—binding with iron wire; *g*.—a fir pole; *h*.—upper fir transverse. Fig. 1, is to a scale of $\frac{1}{30}$ fig. 2, 3, and 4 an to a scale of $\frac{1}{40}$.

A "large sledge" weighs about 40 Kilog. (88 lbs.) and cost 18 francs; a "bouc" or fuel sledge weighs 20 Kilog. (44 lbs.) and costs 8 frs.

†In this way neither the notch nor the wedge are any objection; scarcely a trace remains after the axe has been applied preparatory to sawing. In any case, nothing but the outer slabs, which are of small value, would be injured.

When the slope falls below this figure and remains below it, sledging with the "bouc" is not practicable. In that case one substitutes for the friction of wood on earth the lesser friction of wood on wood. With this view the logs are loaded out a sledge of sufficient length,—the "large sledge" (fig. 2) intended

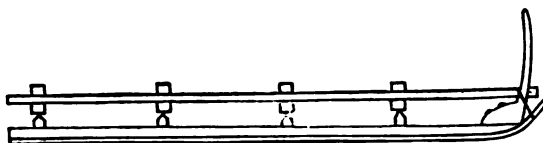

Figure 2.

to glide on cross-pieces spaced on an average 0.60 metres (23.4 inch) these cross-pieces are called "ravetons." The sledge ought to press equally on all the cross-pieces, and consequently the placing in position is carefully done. Two long pieces, fixed at the same distance apart as the soles of the sledge, are used to regulate, according to a succession of regular inclines, all the surfaces of friction. Each cross-piece is firmly fixed in place by two pegs (fig. 3), which both hold it and

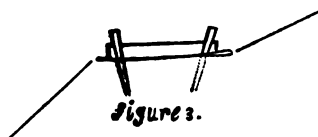

Figure 3.

keep the sledges on the line. They are placed nearer together in proportion as the incline diminishes, and are far apart when the incline approaches 20° ; in the latter case they simply consist of small branches and give but little support to the sledge, which scrapes the ground in the intervals. If the incline becomes less stiff "lattes de rebût," split fir, or "rais de sapin" are used; yet less steep, and one uses "quartiers de hêtre"* and if it is very slight, one harnesses bullocks to the sledge. Should the slope be considerably pronounced throughout the length, the sledgemen are careful to furnish their sledges with soles of soft green wood; while well-greased soles of dry wood are useful on mild inclines. Alternations of dryness and damp, although less marked in forests than elsewhere, have nevertheless a great effect on the sliding. Fine weather eases it, so that on stiff inclines the pace of the sledge increases, while, on the other

*Generally one uses "rais de sapin" between 15° and 7° ; "quartiers de hêtre" are used when the incline remains steadily for some distance below 6° . This last year, a wood merchant has constructed, in order to get over a ridge, a bullock sledge road with cross-pieces of beech. He has thus brought up 1,500 stères (22,280 c. ft.) of fuel. The slopes vary from 3° to 11° on a length of 1,200 m. (3,936 feet.)

hand, the effort required to draw the sledge is also easier on the slighter gradients. Naturally, rain has the exactly reverse effect.

Like the "bouc," the "large sledge" receives about 40 planks, similarly also, when by reason of the load or the gradient the effort required becomes excessive, several men are necessary to bring down one sledge. If the length of the logs is more than 4 metres (just over 13 feet) the "large sledge" is replaced by a couple of sledges joined together. The front sledge is an ordinary "bouc." In addition to the forward man guiding, there is a second who guides the movements of the "chèvre," or after sledge, by means of a rope or pole. One can in this way convey timber of all lengths, whether sawn or in log. Fuel is carried on a sledge with four uprights (fig. 4) between which it is piled. It can be

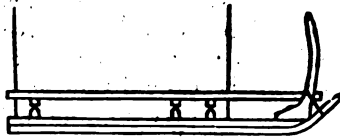

Figure 4.

used on any gradient, but while with cross-pieces nearly two "stères" (70.6 c. ft.) can be carried, it often happens that scarcely half a "stère" (17.7 c. ft.) can be carried on "bouc" roads.

In fact sledging over the ground itself with gradients of from 50 to 20° is quite distinct from sledging over cross-pieces with a gradient of under 20°. This latter requires generally regular roads built at the expense of the owner of the forest, while the former requires nothing, but a slight expenditure that the exporter can always himself manage. The sledgemen themselves mark out the "bouc" roads, simply removing the rocks and using the hoe a little. On the other hand a sledge road made with cross-pieces, requires a regularly levelled road at least 1.20 metres (3.94 feet) wide, so that it necessitates an immediate expenditure that an exporter will never wish to incur, in addition to the fact that a single year's use of it will not always repay him. Consequently the cartmen go beyond the metalled roads to cart over the natural ground of Vosges sandstone however wretched it may be.

It is true that some sledge roads exist, but they were marked out without any method and without any other care than the requirements of the moment. They are therefore generally defective and do not present all the advantages which, had they been properly conceived, they would have done. During the last four years the attempt has been made to construct them in a more rational manner. The roads undertaken during this period are of two kinds.

The first traverse the secondary valleys and end in the principal valley at the metalled road. It frequently happens that the valleys present gradients suitable for sledging with cross-

pieces, but are too slight for the "bouc." As long as a sledge road is made, then the cartmen are simply obliged to go up these valleys to get the wood where the "bouc" has stopped. It is only their passage which, after a long lapse of time, has marked out a few tracks taking the place of roads. Carriage is very difficult, rocks alternate with holes and the soil presents such inequalities that were the loads put on the carts above the axles they would not be sufficiently stable. Consequently they hang them below the axles with chains and iron wedges. These wedges are driven into the wood deeply at the ends, causing damage to several of the planks which are eventually to come out of the log, and in consequence they are sold off cheaply. This loss may be estimated at 10 fr. per thousand planks. As to "paunes" and "chevrons," they are dragged by a chain; fuel can only go out in smaller quantities. Finally, since it would be impossible to remove pieces of great length, such are not extracted in this sort of place. It is almost only along the roads that these can be worked out without difficulty and inconvenience. On slopes, in fact, without sledge roads with cross-pieces, it is impossible to sledge them; one can only roll them down, guiding them more or less with levers; one sledges with the "bouc" small scantling and logs of 4 metres. The exaggerated use of the "bouc" instead of the "large sledge," and particularly rolling, cannot be done without considerable damage to the standing trees. In order to avoid these methods, a regular sledge-road traced along the side of the slope is requisite. Cutting across all the "bouc" tracks, this hillside road collects the outturn of everything above, which it brings to the road in good condition. Throughout the ground traversed it allows of the removal of long pieces. If it can end in a saw-mill it has besides the advantage of a direct carriage without transhipment.*

The first attempt was made in 1887, with this view. A hill-side road was then begun at a uniform gradient of 14° on the North slope of the "Bouton." At 0·50 frs. the running metre, the cost of cutting came to 412·50 frs. (£16 to £17). The "large sledge" partially substituted for the "bouc" and for carts, has produced a saving of 18 frs. on a thousand planks. The number of planks so exported during the last few years has been 26,000, so that up to date the saving has come to 468 frs.†

*These hillside roads would replace advantageously the working plans lines which follow the steepest course and when so marked out are without utility either for export or even inspection.

†Since writing this, this they have just finished, in that neighbourhood, a sledge road 2,395 metres long (8,056 feet). From the ridge the logs are brought straight to the saw-mill at 100 frs. per 1,000 planks; formerly the cost was 170 frs.; 80 frs. sledging with the "bouc" and 90 frs. cutting.

(One franc = $\frac{4}{5}$ shilling.)

In 1888, it was necessary to make arrangements for exploiting four lots marked in the Canton des Tendelins, estimated at 53,000 planks. The road made for this ramifies through a length of 1,096 metres (3,595 feet) in the valleys of L'Homme tué and des Tendelins. The cutting cost 493·20 frs., or 0·45 frs. the running metre. Formerly the cost of transport to the saw-mill per 1,000 planks was 120 to 125 frs., this has been reduced to 100 frs. through the institution of a sledge-road with cross-pieces for carting over natural ground. If besides, one counts the 10 frs. made by no longer loading carts underneath, the saving rises to 30 frs. per 1,000 planks, and on all the four lots to 1,590 frs. Then the Tendelins sledge-road serves an extent of 30 hectares (74 acres) and will have to furnish for a long time to come, important products, of which 100,000 planks have to be turned out at short notice.

This being permanent, roads have to be laid out with care. For hill-side roads one adopts a gradient as suitable as possible to sledging and throughout the length of the road, it is kept nearly uniform. The effort exerted by the sledgeman appears least at about 12°; this gradient should correspond to the co-efficient of friction of the moving sledge on the cross-pieces. This is the best, but if the fact of its being necessary to serve some particular area of the hill face to come out at some fixed point, obliges us to change this gradient, we can, according to circumstances, force it up to 15° or reduce it to 9°. We can scarcely go beyond these bounds. In fact, every sledge-road thus regularly built for using the "large sledge," is a circuit compared to the line necessary for the "bouc," which can descend much steeper slopes, and if the former does not repay its greater length by much greater ease of transport, the sledgemen will refuse it and will be always cutting across with the "bouc."

For the roads along the valleys (chemins de fonds) it is a different matter. There, the question of gradient is encumbered by the necessity to serve the two hill-sides. The ravine must be followed as closely as possible, so that the first point to be considered is how to run the line so as to continually serve the two slopes, the one thing to be careful about being to avoid floods. It is generally sufficient to clear out the bed of the stream, hollowing it out in places, and to protect the embankment of the road with rocks dug out when cutting it. The levelling has scarcely any other use than to see whether or not sledging is possible. On the other hand, the levels determine the direction of a hill-side road, so that in this case one practically takes a given gradient and follows it down the hill-side.

As to the specification of such a project it is as simple as the actual laying out on the ground. Below we give one for a sledge-road projected this last year: Breadth 1 m. 30 (4·3 feet) and longitudinally the slopes to be as follows:—

	metres.		metres.
18° on a length of	38.50	22° on a length of	60.00
15 " "	23.00	12 " "	182.80
12 " "	32.50	8 " "	134.70
13 " "	29.00	12 " "	34.50
14 " "	26.50	14 " "	50.00
13 " "	32.00	15 " "	106.90
16 " "	35.50	13 " "	104.50
13 " "	204.10	11 " "	98.50
14 " "	26.50	12 " "	45.60
13 " "	41.00	11 " "	142.10
19 " "	62.00	9 " "	32.00
16 " "	39.40		
21 " "	26.40		<hr/> 1609.00

1 metre = 3.28 feet.

1,609 metres @ 45 centimes the running metre = 724.5 frs

5,278 feet @ 4½d to 4¾d ... = £ 28.8.

To this price, which is that of the earthwork of the roadway, we should add the cost of making and placing the cross-pieces. In one day, for which he receives 5 frs. (nearly 4 shillings), a sledgeman can use a "stère" (35½ c. ft.) of "raisde sapin" to serve as cross-pieces for a length of 50 metres. The value of the wood fashioned and carried is at the outside 5 frs., so that per running metre the cost is $\frac{5 \times 2}{50} = 0.20$ fr.

If the cost of construction of roads of this kind is so very low, that of maintenance is not less so. The roadway suffers no wear and tear, and, thanks to the cross-pieces, the rain does not cut it up, forming as these do a succession of small "pankaltahs." A bank of earth becomes formed over them and the rush of the water is stopped. After a few storms the original slopes are replaced by a series of steps of which the profits remain uncharged. In fact the maintenance merely consists in changing the rotten cross-pieces. Their life is from 5 to 10 years, say 7 years; consequently the annual cost of maintenance is per running metre $\frac{0.20}{7} = 0.03$ frs.

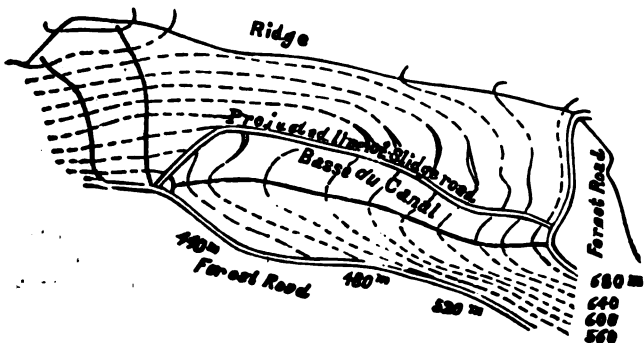

Such a project as the above includes no special works and should require, on the longitudinal section, very slight changes of level. It is under these conditions that the sledge-road is economical. We must profit by this flexibility which allows us to turn and twist with the natural ground, crossing it as we find it without expensive works. The moveable tramway is no doubt much more seductive, but in the first place, it costs, at the least, 3 or 4 frs. per running metre as cost of original construction. In the second, the traffic must be very brisk to cover the capital employed. Finally, traction on iron can only be done within relatively limited gradients. These restrictions go to shew that if such means of transport is applicable in a forest it would be rather on the principal arteries than in the secondary ramifications. Then, on the other hand, the sledge-road is in its true place as far as mountains are concerned. Let us not neglect it as too primitive; let us make as much use of it as possible.

Practical Forest Training Grounds for the Coopers Hill College.

In an editorial written presumably by Mr. Fernandez which appeared in the 2nd Quarterly No. of the *Indian Forester*, for 1890, at page 165, the question is raised whether preliminary practical training in a selected forest district in Germany should not precede the theoretical forest course at the Coopers Hill College, and I wish to discuss here the pros and cons of such a course, on general grounds; having done so, I hope to demonstrate that our Indian Forest probationers have now probably better opportunities for practical instruction in forestry than those of any other European Forest School.

During the first three years that men were trained in France for the Indian Forest service, it was arranged that after passing the qualifying examination for admission as Indian Forest probationers, they should spend six months in Alsace under M. Clément de Grandpré, *Inspecteur des forêts*, then in charge of the extensive forest of Haguenau in the flat country north of Strasburg between the Rhine and the first slopes of the Vosges mountains. This enabled us to learn a certain amount of forest botany, and to become accustomed to the French systems of management of Scotch Pine and Oak, beech, and hornbeam forests; and at the same time to improve our knowledge of the French language and of the customs of the country, all of which acquirements were extremely useful to us as a preparation for the

In 1890, 10,605 metres of sledge-road (4,919 metres hill-side and 5,686 metres valley roads) were made, costing an average of 0.51 frs. per running metre for the earthwork. According to circumstances, the cost varied from 0.30 fr. to 0.65 fr.

subsequent course of forestry instruction at the Nancy Forest School. Whilst, however, I consider that six months could not have been better spent than in the manner arranged for us by Sir Dietrich Brandis, considering that we were to follow a course of instruction for our profession in a foreign language, although a better district might have been chosen than Alsace for increasing our knowledge of French; yet the case is different when men are to be instructed in their own country. It may then be a mistake to lay stress on the advantages of a preliminary training in forest work, before a student has studied the complete theoretical course of forestry. When we read, as in the article in the *Indian Forester* already referred to, that the Coopers Hill forest students should have a preliminary probation of some months in Germany, I must confess to being sceptical as to the necessity for such a plan. Opinions in Germany are much divided, on the question of placing forest students for a term of practical work in a selected forest, before their theoretical instruction has commenced; in fact, if the Coopers Hill authorities are wrong in not arranging for a term of practical forest work for our students, they err in very good company.

Since 1837, it has been the practice in Hesse Darmstadt that the practical course of forestry should follow, instead of precede the theoretical course, and surely no one is bold enough to maintain that the Prussian system which prescribes the opposite practice, can show better results than the well managed forests of Hesse Darmstadt, where forest officers, for the last fifty years, have been trained on similar principles to those now adopted at Coopers Hill; nor than the forests of Bavaria, Baden and Wurttemberg, where the same system is also in force. The idea of setting the practical before the theoretical course of forestry, chiefly arises from a sentimental hankering after old times, when forest students acquired most of their professional knowledge, under experienced practical forest officers, and merely superadded thereto a little theoretical instruction. Gradually, however, more and more scientific teaching has become necessary until, now-a-days, demands on a superior forest officer are so great that, if a student's theoretical studies are to be interrupted by a term of practical work, he may become unsettled and only able with difficulty to resume their thread afterwards. If moreover, on the one hand, lectures may be better understood by a student, after a term of practical work in the forests, on the other hand, there can be no doubt whatever, that the forester who has completed his theoretical studies, provided they have been sufficiently illustrated in the forest, will pick up the necessary practical knowledge in less than half the time the former will take, *cæteris paribus*, to do so.

It will interest old pupils of Clément de Grandpré to hear that after filling the posts of Conservator of Forests at Epinal and of *Inspecteur Général* at Paris, he is now residing *en retraite* at Versailles.

Every forest school should evidently have a sufficient area of forest readily accessible, where forest botany may be studied, and where lectures in silviculture may be illustrated and practical instruction afforded in planting, sowing, thinning and other silvicultural operations; also in measuring trees and in estimating the contents of woods. This, however, is quite a different matter from setting a student down in a foreign country, or even in his own, to follow practical work without having previously studied all the phases of present European forest management. The officer to whom he may be deputed, will probably be biassed in favour of a particular system of management, which may be admirably suited for that locality, but not for others. Any lover of forestry who has travelled in Raden, Wurttemberg or Saxony, will at once note how zealous the forester in Saxony is for clean fellings and artificial planting; in Baden, for the group system, and in Wurttemberg for the shelter wood compartment system of natural regeneration, largely supplemented by planting:—were an English Forest student to be placed in a forest district in any of these countries, before he has been taught in the lecture room to compare all the systems impartially, he might acquire such a prejudice in favour of a particular system in vogue in that district, as to impair seriously the benefit he should derive from a subsequent course of instruction, even in the best forest school in Europe.

An Indian Forest Officer may object to this assertion, on the ground that candidates for admission to the Dehra Dun Forest School are required to pass a season of probation in an Indian Forest, but this condition was arranged chiefly in order to ascertain whether such candidates were qualified for the Indian Forest Department, by love of outdoor pursuits, and by sufficient strength of constitution and active habits fitting them for hard work in the Indian Forests. Indian candidates are frequently fond of sedentary pursuits, and many of them dread the dangers and discomforts of a life in the forest service, and it is notorious that they generally make more efficient judges and pleaders, than active administrators in the land revenue, or Forest Departments.

This cannot be said of young Englishmen; our public schools, owing to the active sports which form such a prominent feature in English School life, turn out young men well fitted physically for the forest service. No candidate is admitted to the Coopers Hill College, for the Indian Forest service, unless he can walk twenty-five miles in seven hours, without showing undue sign of fatigue, besides having to pass strict medical examination at the commencement and end of his course; and to obtain a riding certificate, before he proceeds to India.

To make the case against setting practical experience before theoretical training quite general, I may compare our profession with that of medicine or engineering: though young doctors learn much from attending hospital cases, and engineers

from inspecting extensive works under construction, yet it is not at the commencement of their studies that the former are set to work in a hospital, nor the latter on new railroads; at first they only attend these practical operations, after having acquired the necessary knowledge to understand the general drift of what is being done, and with a qualified professor at hand, to explain every step of the business. It is not clear why forestry instruction should proceed differently to that in other professions, and it no more follows that every practical forester is capable of teaching students, than that every medical practitioner and every railroad Engineer can do so.

In addition to the general grounds for rejecting the idea of a preliminary practical course of forestry in Germany, for our students, I hope to show that we have near Coopers Hill, and accessible to us in a short time by rail and steam boat, a great variety of forests, where we can impart the necessary practical instruction until the completion of our theoretical course; then in order to study Forest Management and Utilization more completely, our students make a prolonged continental tour in order to see practical illustrations of all they have learned in the classroom. It is a common idea that the woods near Windsor form merely a deer park, with a few enclosures for pheasants and rabbits. This is very erroneous, for inclusive of the Windsor Park of 5,000 acres, there is between Coopers Hill and Sandhurst, a distance of 15 miles, a total area 9,000 acres of forest under the administration of the Woods and Forests Department, besides a large area of private forests. The crown forest of Windsor, includes a well stocked oak wood of 1,100 acres, planted in 1816 for the use of the Navy; many other smaller plantations of oak, beech, silver fir, larch, spruce, scotch pine, chestnut and hornbeam, planted at different periods, and on the sandy heather soil extending from about two miles to the south of the College as far as Sandhurst, there are extensive areas under scotch pine with a mixture of Weymouth and maritime pines, all of which species reproduce themselves naturally in abundance, and are systematically protected, chiefly in the dry months of March and April, against the forest fires which nearly every year burn over large areas of heatherland and scotch pine woods belonging to private owners adjoining the Crown forests. Eight hundred acres of this Scotch pine area, known as Cæsar's Camp forest, have been leased from the Commissioners of Woods and Forests expressly for the forest branch of the Coopers Hill College, and are being managed by Dr. Schlich according to Judeich's *Bestand-wirtschaft*, modified to suit the locality, which means that each compartment can be treated in accordance with its peculiar sylvicultural requirements, without insisting on a fixed annual yield. In this forest, the College has contracted to spend £300 annually, and this expenditure is disbursed under the following heads

	£
Forest Guard's pay ...	52
Plantations (about 30 acres annually.)	150
Fire conservancy, roads, &c., ...	98
	<hr/>
Total	£ 300

No money spent on fellings or thinning is shown here, but all such expenditure is deducted from the sale proceeds of the timber, the balance being paid to the Commissioners of Woods and Forests. This little forest offers a fairly good site for the students to study plantations of Scotch and Weymouth pines, larch, Douglas and silver fir, beech and spruce and for noting the results of natural reproduction chiefly of coniferous species; also for observing the effects of under-planting Scotch pine and oak with shade bearing species and for making all the necessary measurements and valuations necessary for the computation of Working Plans. Within the grounds of the College, there is an area of 10 acres, where fine standards of oak, ash, and maple, sweet chestnut, wild cherry, and Scotch pine are growing over a coppice of hazel and other species and there is a forest nursery, where the material for the Cæsar's Camp forest plantations is raised, so that we have a constant succession of young plants to show the students. Another adjoining area has been subdivided into little plots on which oak, beech, hornbeam, alder, birch, larch, Scotch and Weymouth pines, silver and Douglas fir, and suitable mixtures of these species have been planted to illustrate the forestry lectures. Within a mile from the College, along the course of the river Thames there are extensive well managed osier beds, and at Esher, 12 miles from Coopers Hill, is a Crown coppice with standards of 800 acres, the coppice chiefly ash, oak, chestnut and hazel and the standards chiefly oak. This area is regularly subdivided into annual coupes and thousands of ash and chestnut saplings are planted out annually to improve the crop. In the Chiltern Hills, beyond Windsor, are any number of prime beech woods, and one of them near High Wycombe, belonging to the Hughenden Manor, is visited every year by the students. This wood consists of 160 acres subdivided into 7 necessarily equal compartments, in one of which the fellings take place annually according to the selection system, or *jardinage*; the trees being allowed to attain an approximate age of 90 years before they are considered mature, and the regeneration being entirely natural.

The Epping Forest is also visited annually by the school, consisting of an area of 5,300 acres, chiefly composed of hornbeam pollards, with large standards of oak, beech and other species. The pollards are frequently crowded to the extent of 700 to the acre, and as all pollarding has ceased since 1878, the growth of pollard shoots has formed a kind of tall Coppice growth commencing at 8 feet from the ground, and the future management of this extraordinary wood therefore presents many difficulties. There is also, in the Epping forest, a splendid thicket of 1,000 acres of oak,

beechness and hornbeam, where the pollards had been all cut down more than 20 years ago, and which has now been to a large extent re-stocked by seedlings.

From the above description, it can be easily seen that a finer situation for the study of forest botany could not be found, for in the Windsor forest, oak, beech, elm, chestnut, hornbeam, ash, maple, larch, silver fir and spruce, and Scotch and other pines attain fine dimensions, and trees of all ages of these species are to be found. I think I am quite right in saying that every forest tree which has ever been planted in Great Britain is to be found within Windsor Park, or its neighbourhood, whilst our students supplement their studies of Forest Botany for temperate, sub-tropical and tropical forest vegetation in the magnificent Kew Gardens and Museums. Within a walk or drive from the College are many interesting woods, already referred to as visited regularly by our students, which serve admirably for the study of silviculture, and to some extent of forest management. I must not here omit mentioning the extensive Summingdale nurseries for nearly all kinds of trees and shrubs, where every possible procedure for propagating rare and curious species and varieties of woody plants may be studied; nor the Windsor Park nurseries where oaks, elms and other trees are trained to use as large transplants. Opportunities also occur for studying the destruction by forest insects and fungi, for unfortunately the pine, silver fir, and larch cancers and other destructive fungi are common in the neighbouring woods, and *Hylurgus piniperda* and *Tortrix viridana* regularly attack the pines and oaks in Windsor Forest on a large scale, whilst various species of *Bostrichus* attack dead timber, and many other destructive insects may be found. Our field for the practical study of forestry, however, is not yet by any means exhausted; within twelve hours journey from London, there are in Normandy, I speak advisedly, the finest beech, oak and hornbeam forests in Europe. These forests are managed according to the french system of *Coupes successives de régénération naturelle et des éclaircies*, and these we visited with the first-year students this summer and intend visiting them annually. At Syons, near Rouen, is a State forest of 26,000 acres, where whole woods of nearly pure beech, in 160 years attain an average height of 150 feet, with average diameters for the trees, of 3½ feet, at 4 feet from the ground; here natural regeneration is easily effected within from 10 to 15 years. Further on, near Montagne, is a magnificent forest of oak and beech and hornbeam, where mature woods in 200 years attain a height of 130 feet with an average tree-girth of 8 feet, and which are regenerated naturally in 12 years. The splendid growth of oak and the magnificent natural reproduction in these woods, due to the maritime climate, and the deep loam of the tertiary strata, on which they stand, cannot be surpassed. Within a day's drive from Montagne, we also saw a coppice with standards under conversion to high forest, and on our return journey from Normandy *via* Calais, we visited, near

Valenciennes, two splendid examples of coppice with standards; one a State Forest of 8,300 acres, subdivided into 15 working circles, and the other a private forest of 3,000 acres, and with rotations of 25 and 12 years respectively for the coppice. At the close of our second year's course at Coopers Hill, our forest students make a working plan of a portion of the Cæsar's Camp forest: during their third year, at the completion of their theoretical training, they are sent on a prolonged tour in the forests of Germany, Switzerland and Austria, under Sir Dietrich Brandis, and prepare a working plan in a selected forest, and this term of practical experience in the Continental forests may, at the discretion of the authorities, be extended to six months.

Now, besides having studied at the Nancy forest school, I have accompanied students from the forest schools of Aschaffenburg, Tubingen, and Carlsruhe on excursions in the German Forests, and I believe that I am right in asserting that no forest school in Europe, can compare with our Coopers Hill training, in the great variety of forests visited, nor in the comprehensiveness of the teaching of forestry, theoretical and practical, as instituted by Dr. Schlich.

Nancy forest officers who were trained between 1867-1886, will remember that the tours made by the French students never extended beyond France, and last year during my six months tour in the forests of Wurttemberg, Baden, Saxony, Bohemia, Bavaria, Alsace and Switzerland, I heard complaints that German forest officers did not see enough of what was going on even in the neighbouring countries of Germany.

Having now explained how matters stand at Coopers Hill, I think that Indian forest officers, after perusing the programme for instruction contained in the last College Calendar, may feel confident that the recruits we are sending them will have seen quite enough of European forests and that they are receiving a training well qualified to fit them for the new ideas involved in Indian forest management, which could not be improved upon if they had received their training at any forest school on the continent.

Whether, after their arrival in India, it would be well, as Mr. Fernandez has suggested, that junior forest students of the Imperial service should spend a cold weather season in the forests of the Dehra Dún Circle, where Indian forest management has presumably progressed more rapidly than elsewhere, I must leave for future discussion. It is, however, certain that here we can only chiefly teach the general principles of forestry and that their practical application to Indian forests must be acquired in India itself, although the professors at Coopers Hill always illustrate their lectures with reference to Indian requirements, and a special set of lectures on Indian silviculture are given by Dr. Schlich, and another set on Indian forest law and management by Mr. B. H. Baden-Powell.

W. R. FISHER.

Mr. Fisher seems to think that we all see the Coopers Hill Calendar; we wish he would send us some copies, for there is not one even in the Dehra Dún Forest School Library.

HON. ED.

An Interesting new Product.

In our October Number, at p. 385, we noticed the specimens of *Saussurea Lappa* sent us from Cashmir by Mr McDonell under the above heading. We have, however, just received from Mr. D. Hooper at Ootacamund, the well-known analytical chemist and quinologist, and part author of the new 'Pharmacographia Indica' a Postcard to tell us that there is a very complete account of the "Kuth" in that work at p.p. 296 to 303 of Vol 2; and that it is quite a mistake to call it 'new.' No doubt we were wrong in using the word 'new'—we used it in the sense that it was an article of forest produce of which we had never heard before and our note shewed sufficiently that we could not have meant that it was 'new' in the sense of 'recently discovered' for we distinctly referred to authors who spoke of it as old. We are sorry we omitted to consult the 'Pharmacographia Indica' before writing, but believe our omission to do so was due to our thinking that it had not got quite so far, and indeed the 'Saus-surea Lappa, takes the very last pages of what has been published up to date. Nor did we consult, as we should have done, Baden Powell's 'Punjab Products' for in that work the following are given as the uses of the drug.

" 1st. Dried and powdered as the principal ingredient in an 'astringent stimulant ointment, applied to severe ulcerations.

' 2nd. Dried and powdered as a hair wash.

' 3rd. As a stimulant in Cholera; an infusion is made of 'Cardamoms 1 dr; fresh 'Kut' 3 drs; Water 4 ozs. One ounce 'every half hour. It is doubtless a powerful aromatic stimulant 'and would be serviceable in any spasmodic disease.

' 4th. It is universally employed by the Shawl Merchants as 'a protector of Cashmere fabrics from the attacks of moth and 'other vermin.

' 5th. The dried root is an agreeable fumigatory, and yields 'excellent pastilles, which burn freely.

' 6th. It is exported in enormous quantities to China, where 'it is used as an incense. In every Houg it is found; no mandarin 'will give an audience until the 'Patchak,' incense smokes before 'him; in every floating junk on the Chinese rivers, the only 'house of countless hordes, Budh's image is found, and the smoke 'of the Patchak religiously wends its way heavenwards. As to its 'uses in China, Dr. Porter Smith says that it is used in making 'incense in the South, or to preserve clothes from attacks of moths 'and other insects. It is said to have the power of turning grey 'hair black. Carminative, stimulant, antiseptic, prophylactic, astringent, sedative and insecticidal properties are referred to this 'remedy. The Chinese apply it with musk, which it resembles in 'odour and properties, to aching teeth."

We need not quote the history of the drug, our readers can refer to Messrs. Dymock, Warden and Hooper's book, but we

think it will be well to quote the *Description* of it as a trade article and the paragraph on *Commerce*.

"*Description*."—Costus occurs in crooked twisted pieces 'about 3 inches long, and from $\frac{1}{2}$ to $1\frac{1}{2}$ inch in diameter almost 'always split. Externally it is brown, marked by longitudinal 'ridges, and has a rough and somewhat reticulated surface. Its 'substance is compact and brittle, the fractured surface having a 'resinous appearance and dirty white colour. The central portion 'is generally absent, and appears to have been removed by decay 'before the root was collected. The taste is bitter, pungent 'and camphoraceous; the odour resembles that of fresh violets or 'orris roots.

'*Commerce*. The roots are dug in the months of September 'and October, when the plant begins to be torpid; they are 'chopped up into pieces from 2 to 6 inches long, and exported 'without further preparation. The quantity collected is very large, 'amounting, as far as Dr. Falconer could learn, to 10,000 or '12,000 *Khurwars* (load of 192 lbs.) The commodity is laden on 'bullocks, and exported to the Punjab, whence it finds its way to 'Bombay, and a portion to Calcutta through India. In Dr. 'Falconer's time, the cost of collection and transport was about 'half a crown per cwt. Cleghorn states that it is also exported 'from Pangi on the Upper Chenab to the plains. The loads of it 'when passing scent the air to some distance. Davies' "Trade 'Report" gives 29 maunds as exported to Afghanistan *via* the 'Bolau. Royle mentions that in one year (1837-38) 6,697 'maunds of this root, valued at Rs. 99,000, were exported from 'Calcutta to China, and in 1867-68 nearly Rs. 10,000 maunds. 'In Cashmere, the Maharaja is said to take it over from the 'collectors at half the price at which it sells again. In 1864, his 'income from this source was put down, on good authority, (accord- 'ing to Dr. Stewart) at Rs. 300,000 Chilki, equal to nearly 'Rs. 1,90,000 but this, he adds, is scarcely credible*. Kut is 'imported into Leh in small quantities from Cashmere for exporta- 'tion to Lhasa, where it is called, as well as by the Bhotes, '*Rusta*, and is used for incense. In 1871, 33 maunds were 'imported into Leh from Cashmere, valued at Rs 692 According 'to Dr. Falconer, at the time he wrote, the cost of collection and 'transport to a depôt in Cashmere was 2s. 4d. per cwt: on 'entering India its value was enhanced to from 16s. 9d. to '23s. 9d. per cwt, whilst the commercial value at Canton was '47s. 5d. per cwt. From the Consular reports, it appears that 'in the year 1875 the imports of Costus into two Chinese ports 'only were: for Hankow 1,270 piculs, valued at £5,224-6s 3d.; 'and for Cheefoo 277 piculs, valued at £1,197; so that it is clearly 'no insignificant article of Chinese Commerce. (Cooke, in 'Phar. Jour. 21st July. 1877.) The value of Costus in Bombay 'averages Rs. 10 per maund of $37\frac{1}{2}$ lbs.

*In the last Official Reports. the export of Chob-i-koot to the Punjab are valued at Rs. 16,000 only, but under the head of drugs, &c, there are exports valued at Rs. 1,00,000, part of which may possibly be Costus.

Leaf-fungus on *Ehretia serrata*.

In our August 1891 Number, p. 303, we referred to the lamented death of Dr. A. Barclay, one of the few Indian students on the very important subject of the fungoid diseases of forest trees. Scarcely a month before his death, a paper on the subject of Uredinæ from the North-West Himalaya was read before the Asiatic Society of Bengal and in it we find an account of '*Uredo Ehreticæ*' a leaf-fungus which was found growing in conspicuous orange patches on the leaves of *Ehretia serrata*, when the Forest School students were in camp at Thadyar on the banks of the Tons in May, 1891. The following were Dr. Barclay's remarks.

'UREDO EHRETICÆ NOV. SP.

'ON EHRETIA SERRATA, ROXB.

"This fungus was collected by Mr. J. S. Gamble on the banks of the Tons river near Chakrata. The leaves are attacked by a Uredinous fungus of somewhat uncertain nature. Some leaves had circular spots varying in diameter from 1 to 8 m.m. whilst others had large hypertrophies of the petiole as it enters the lamina, and these were uniformly covered with bright orange red pulverulent spores. Transverse sections through the fungus and leaf show that the spores are not borne separately on stalks, but from a cup-like depression like the pit of an aecidium without any peridium. There were also numerous superficial spermogonia. The spores are orange red, oval or pear-shaped, very spiny, decidedly thickened at the free end (remining one of the æcidio-and uredospores of *Puccinia Prainiana*). They become detached without any portion of the stalk adhering. The spores are given off from both surfaces of the leaves. By applying nitric acid I saw that each spore had two germ pores.

'This is the first member of the Boragineæ which I have seen attacked in India by a Uredine. As *Puccinia Rubigo-vera*, or some variety or allied species, is undoubtedly the most prevalent and destructive rust on wheat, barley, and oats in India, I had long looked for some associated form on a Boragineous host, and this not only by personal search, but also by correspondence. I am afraid, however, that this particular Uredine cannot be the associated form I have been looking for although it is just possible that it is. For although the spores are given off like uredospores, the cup-shaped depressions in which they are formed, the presence of spermogonia, and the hypertrophy of the hosts tissue all render it possible that we have here an anomalous Aecidium. This question will have to be tested by experiment."

Among other important tree-fungi described in the same paper were *Melampsora ciliata* a light yellow Uredo found at

Simla on *Populus ciliata*, *Melampsora acidoides* an orange-red fungus found by Mr. Lace at 8,500 feet on *Populus alba*; *Uredo Colebrookiae* found by Dr. Watt, near Suni on *Colebrookia oppositifolia*, also of an orange red colour; and *Aecidium Cunning hanianum* found at Mahasu and Narkanda by Dr. Barclay, and supposed by him to be identical with, and alternate to, the Cypress fungus, *Gymnosporangium Cunninghamianum*.

II. CORRESPONDENCE.

A Hand Seed-drill.



DEAR SIR,

I herewith send a rough tracing from Messrs. Walsh Lovett's Catalogue. The instrument shown in the diagram is called a "hand seed-drill."

It is 'suitable for filling up blank places in fields, and for all kinds of garden drilling. It can be adjusted for sowing almost all kinds of seeds. The moment it is lifted off the ground, the seed ceases to fall through. A boy can work it as fast as he can walk. Prices one row 10s. 6d. Two rows £1-2-6.'

It occurred to me that this machine, costing say from Rs. 7 to Rs. 15, might be very useful in "broad-cast" sowing; as it gives apparently scarcely any more trouble than that method, whilst at the same time it makes its furrow for the seeds.

I therefore forward this to you, in case it may be of use to any of your readers.

A. W. LUSHINGTON.

III. OFFICIAL PAPERS & INTELLIGENCE.

Bengal Arboriculture.

In reviewing the work of the land Records and Agriculture Department in Bengal for 1890-91, the Lieutenant-Governor writes as follows:—

“*Arboriculture.*—With the exception of the planting of fruit trees along the road-sides, which must be regarded rather as an administrative measure adopted for shade purposes and the preservation of road alignments, than as an agricultural experiment, the arboricultural efforts of the department do not seem to have been extensive or productive of much practical good. The Lieutenant-Governor does not, for instance, see much use in planting date-palms where nature has not planted them, or in pushing artificially the cultivation of such trees as the *Eucalyptus*, *Divi-Divi*, or the *rain-tree*.”

Though we are not quite sure that we agree with him entirely as regards the *date*, the edible variety of which, though unsuited to avenues, we consider to be well worth some pains and expense to bring into general cultivation as a valuable food crop; or the *Divi-Divi*, which, though useless as an avenue tree, gives one of the best tans known and is easily grown, very productive, and capable of paying very well whenever the supply of Valloria Oak in the European Market falls short, as it did, we believe, during the Russo-Turkish war; we do argue very strongly as regards the *Eucalypti* and the *rain-tree*. The ‘*rain-tree*’ (*Pithecolobium Saman*) is an exceedingly quick grower, but we believe that it absolutely requires good soil and a moist climate and for such conditions we have hundreds of valuable indigenous trees with splendid timbers and other produce infinitely more useful than the *rain-tree*, whose wood is hardly even a good fuel. As a nurse to other trees, the *rain-tree* has been very useful as in the Calcutta Gardens, but as an avenue tree scarcely a worse selection could be made. Some of the *Eucalypti* again have been grown successfully into trees in various parts of the plains of India, where each individual has been carefully treated and carefully watered and coddled, but on the whole, the success of *Eucalyptus* growing has been very doubtful. In the Nilgiris *Eucalypti* have, of course, been extremely useful and have practically acclimatized themselves, but their value is chiefly due to their extremely quick growth compared to that of the trees of the indigenous ‘sholas’; and where it is possible to plant Teak, or Blackwood, or Padouk, or Mahogany, or Shisham or any other of our good timber trees why should we waste money on the *Eucalypti* whose timbers are comparatively poor, and which have abundantly shewn that in the Indian plains, they possess no

species fit to emulate those acclimatized on the S. India mountains.

If we could take the seeds of the Eucalypti or of the Rain-tree and scatter them broadcast on our poor forest lands like those of Ajmere, of Anraoti, of Bellary etc, and if those seeds would then germinate easily and abundantly and quickly restore the forest, then we should be the first to advise their extensive use; but as they are no use in such places, we shall do better to take Sir Charles Elliot's advise and give them up and stick to our own more valuable and prettier indigenous friends.

IV. REVIEWS.

Government Horticultural Gardens, Lucknow, for 1891.

To judge by the Report before us, excellent work continues to be done in the Lucknow Gardens and not only do the gardens seem to be most useful, but the Report for this year is full of most interesting information on the subject of the growth of fruit and other trees; and so we are glad to notice commendation bestowed on Mr. Ridley by the Director of Agriculture.

The chapter on *fruit culture* records that 1889 was a good year for mangoes, an average year for peaches, lichis, pineapples and jack fruit and a poor one for oranges. Loquats, in the spring of 1890, at which time they are kind enough to appear when other fruits are not available, were a light crop, while here in Dehra Dún they produced very well. The Gardens are continually introducing new fruits. This year the American dewberry (*Rubus trivialis*) is being tried, also the Natal plum (*Carissa grandiflora*) which we are sorry to see does not ripen, for those who have once tasted it in its South African home must regret that it has not yet been acclimatized in India.

In respect to *Arboriculture* much is being done. Large numbers of Forest tree seedlings are regularly raised and distributed, the demand being, apparently, considerable. It is interesting to note the demand for Eucalyptus leaves for the removal of incrustations in boilers and the sale of 18½ maunds of dry bark of the *Broussonetia pappifera* to the local paper mills at 8 as. per maund. A great many palms are found to grow successfully, among them such fine and interesting kinds as the *Oreodoxa regia*, two *Coryphas*, *Hyophorbe Verschaffeldtii*, *Siaforthia Elegans* and *Wallichia disticha*.

We are, however, sorry to note that the edible date is not succeeding so well as it might be expected to do, for deaths have been many. It is pointed out that greater success is obtainable in trenched land than in ground which has not been so treated.

The Agri-Horticultural Gardens, Lahore, 1890-91.

Even the *Agri-Horticultural Gardens at Lahore* must have their annual report and review on it! For the year ending 31st March, 1891, the revenue was Rs. 15,263 against an expenditure of Rs. 23,630. More than half of the latter was incurred on Establishment, and two-thirds of the revenue was derived from the sale of garden produce. We note that mangoes do not thrive well in the Lahore soil and climate, and that only two imported date trees are alive; some 328 seedlings from Tunisian and Persian Gulf dates were distributed to districts.

The following remarks about the orange crop are interesting:—

“The orange crop was very poor. The dull and rainy ‘autumn specially affected the Malta variety. Their flavour was ‘very deficient, and scarcely any of the fruits were blood coloured. ‘Among those received from Mr. Halsey, one tree named ‘“Calabra” fruited for the first time this year. The fruit was ‘much superior to any of the other Malta oranges, it having a ‘decided flavour of strawberry. The tree bore only 3 oranges, but ‘this spring it is bearing a very fair crop.”

An orange with the flavour of a strawberry must be a curiosity, and it is just possible it might lose this flavour outside of Lahore.

The Mahogany is apparently attacked by the grub of a moth in a similar way to the Toon tree; is it the same insect?

“The one Mahogany tree mentioned in previous reports, ‘though in a healthy condition, is making but slow growth owing ‘to the tips of the young shoots being continually attacked by a ‘small grub which eats down into the centre of the young growth ‘which keeps the tree in a stunted condition.”

A. S.

The Nagpore Experimental Farm 1890-91.

The ‘*Report on the Nagpur Experimental Farm in the Central Provinces for 1890-91*’ shews that excellent work is being done in experimental Agriculture. The useful map of the Farm which is published will be a great help to visitors inspecting it, while the description of the experiments leaves no doubt in one’s mind that Mr. Fuller the Commissioner of Agriculture is

doing, what might be more generally done, really good practical work instead of sitting in office and talking about it while fulminating edicts to Collectors. And he evidently is well served by his Superintendent Mr. Mahaluxmivála. The experiments conducted include (1) tillage; (2) embankments; (3) mixture of crops; (4) rotation; (5) manures with trials of (6) varieties of crops; (7) thick and thin sowing; (8) selected seed; (9) saltpetre top dressing; (10) pickled seed. We must refer our readers to the Report for the results of these, as our mention that 'embankment' for the growth of wheat added Rs. 10 per acre to the produce, with manure, and 4-8 without manure; and that the use of green-manure of the common *Cassia arviculata* (Tangedu or avaram of S. India) added 222 lbs of grain per acre to the produce. We will conclude by quoting Mr. Fuller's para 14 on his Agriculture class.

"The condition of the Agricultural class is not quite so 'hopeful as it appeared to be last year. The students who 'passed out qualified last March shewed on their examination 'that the course of instruction is sound and that they had profited 'by it. But this year's entries are fewer than before, and there 'have been signs in this falling off and in the behaviour of 'the students, of a distrust on the part of the educated classes of 'the policy of Government in offering young men inducements 'to undergo a training in agriculture, instead of pursuing their 'education in Arts"—for the 'distrust' is truly characteristic of the country and needs no comment. Agriculture does not pay as a stepping stone to employment: we shall be glad when the Indian Government begins to insist on some scientific and technical knowledge. What would be more useful to a sucking Tahsildar than a practical acquaintance with the elements of agriculture and the various sciences which come into play in its study and practice.

Arboriculture in the Hyderabad Assigned District 1890-91.

The 'Report on Arboriculture in the Hyderabad Assigned Districts, for 1890-91' has not much which we can note. But we regret that the Commissioner has taken no notice of Mr. Dickinson's complaints regarding the felling of fine trees included in village numbers and the non-reservation of space along roads for the growth of trees. In connection with this Report we may, some of us, congratulate ourselves that Conservators of Forests are not everywhere expected to supervise District arboricultural operations; life would be too short for that.

The Departments of Land Records and Agriculture in Bengal and Assam, 1890-91.

The 'Annual Report of the Department of Land Records and Agriculture in Bengal, for 1890-91' contains much of interest to one who knows the Lower Provinces, but little which we can note as of interest to Forest Officers generally. We are glad to see that good maps are being made for the Forest Districts of Orissa, Julpigoree and Chittagong and the capital Index maps of those countries are interesting to the lover of maps. Date palms do not seem to be a success in Behar and Chota Nagpore; may we suggest that a comparison with Egypt would point to the probability of greater success in the upper Districts of the Delta where the sub-soil is likely to be moist, than in Hazaribagh and Palamow, where the rock is so near the surface. The rain-tree is a success everywhere; of course it is! and as it does not even help to reclaim *usar* lands as it was hoped it would, we do not see what use it is to waste money on it, unless some one requires a fuel plantation tree. Eucalyptus (sic) thrives in Hazaribagh, but which kind? As Bentham and von Mueller have described 135 species of the genus, it would be interesting to know the names of those which have been successful.

The similar 'Report for Assam 1890-91' also contains a useful small map of the province, but devotes two and a half pages out of eleven to the tours of the Director and his Assistant; and we note that the Government is not even then satisfied, for special explanation is demanded in future years when any Kánungo spends less than 200 days in Camp! The *eri* silk and the possibility of its introduction from Assam to other Provinces, most rightly demands attention. Castor oil will grow well almost anywhere and we believe that in spite of the difficulty in reeling it off, *eri* silk has a great future in Districts where the growth of Mulberry is impossible. In reference to the Circular of the Government of India about fuel and fodder reserves near lines of Railway, we note the indignant reply of the Commissioner of the Assam Valley Districts 'we suffer from jungle'!

Potato Culture.

We have been favoured with a small manual on Potato Culture by Mr. F. W. Seers, Superintendent of the Ramghur Tea, fruit and potato gardens, Kumaon.* The author proposes to

*Potato Culture: a Manual for Indian Cultivators by F. W. Seers, (W. H. Targett, "Asian" Office, 4 Waterloo St., Calcutta). Price Ra. 1 per copy.

place before the public a simple code of plain practical instructions, such as can be easily explained to the ordinary Indian *Mulee*.

We are first of all shewn that it is quite possible to grow continuous crops of potato on the same plot of ground, provided that care be taken to return to the soil in the shape of suitable manure what has been taken out of it; and if the ordinary cultivator does not do this, but on the contrary changes his plot every two or three years, it is because he does not repay what he has borrowed; in other word he neglects to manure.

The second chapter deals with soils and their preparation, and the characteristics of clays, marls and loams are briefly dealt with. Then we have manures and their application, and it is noteworthy that coal soots and wood ash mixed are recommended. But it may well be asked, where is the ordinary Indian gardener, or his master too, for that matter, to procure coal soot from? It is by no means a common article in India. However, good farmyard manure well rotted down in covered pits is also recommended and this is certainly more easily obtainable; it has in addition the useful qualification of increasing the gross produce per acre about four times; if the standard of unmanured ordinary land be taken at 110 maunds, the yield of the acre prepared with farm yard manure will rise to 450 maunds. For the method of application the reader must be referred to the little manual itself

Under "Seed and planting" we note that the system of cutting up the potato into eyes is condemned, and that the best course is to plant uniformly even, good, medium-sized, whole potatoes. Careful and detailed instructions are given as to the actual sowing or planting out of the potatoes; the subsequent weeding and earthing up and the selection of seed are all practically described; and we rise from a perusal of the 27 pages feeling that we understand thoroughly *how* to plant potatoes successfully. But we are not told *when* to plant, there is not a word from beginning to end to tell us in what month we should lay down the seed, or when we should take the potato up. We trust that Mr. Seers in his next edition will supply this small omission, and inform us what is the best month for planting in the hills and plains respectively, meanwhile we must be guided by the custom of the locality, and we can cordially recommend this little manual to our readers for all purposes of cultivation. We ought indeed to be thankful to any one who endeavours to improve both in quality and in quantity the outturn of this most important tuber. The price of the manual, one rupee, places it within the reach of all.

V.—EXTRACTS, NOTES AND QUERIES.

Diseases of Conifers.

The following extracts from a leading Article in the *Gardener's Chronicle* on the recent Conifer Conference at Chiswick may perhaps be of interest to our readers.

„ Professor MARSHALL WARD, as the representative of our first Forest School, gave an admirable address on the diseases to which Conifers are subject. This address was a model of perspicuity, begotten of full knowledge of the subject. Dealing really with a very technical and complicated subject, Professor WARD managed to put before his hearers, in the clearest manner, an admirable survey of the subject. How so learned a scientist managed to give his hearers so clear a summary, with so little use of technical terms, was a matter of surprise. The word “mycelium” in place of spawn was almost the only technical term we noticed, as, with great skill, Mr. WARD managed to convey a lucid notion of the extremely interesting phenomena of “heteroicism,” which are as important to the cultivator as to the man of science, but which, owing to the technicalities ordinarily made use of, make the subject more or less of a sealed book to the very persons most specially interested from a practical point of view. Professor WARD alluded first of all to the diseases consequent upon a want of balance and proportion between root-action and leaf-action, and to the climatal and other causes which bring about such a want of proportion.

‘Passing then to the consideration of diseases due to the action of fungi, Professor WARD alluded first to those of the better-known fungi, commonly classed as Toadstools and Mushrooms, which attack trees; then to the rust fungi, which affect the leaves in the first instance, and then to the ascomycetous mould. Special attention was given to the “wound fungi,” and to those which gain an entrance through cracks in the bark, or injuries inflicted by frost, insects, animals, and man. He showed how, out of the countless millions of spores produced, there was ample opportunity for the introduction of the germs of the fungi, which, germinating under appropriate conditions, penetrate the wood, absorb the nourishment contained in it, and interfere with the healthy action of the tree.

‘The rust fungi are particularly remarkable in that they pass one part of their life on one plant, and work out another portion of their life-history on some other plant of a totally different nature; the fungus itself in the two conditions being so utterly different as to have led to the application of different names, and to the classification of the forms in different groups. Thus a

particular fungus growing on the common Groundsel or one on a Vaccinium has a totally different aspect when living on a Silver Fir. Practical men will remember with complacency that this relation between apparently different organisms was long ago found out by the farmers, who branded the Barberry bushes as enemies to the Wheat. They were ridiculed at the time for this, but experience has shown that they were right as to their facts, although widely in error as to their interpretation of them. It is not the Barberry bushes that do the mischief, but a fungus which grows upon them. But who, without the minute study that the scientists have made, could believe that the rust of Wheat and the cluster cups of the Barberry have any real connection, or be indeed specifically identical, or that a fungus on the Juniper could affect the Hawthorn, or one on the Groundsel prove prejudicial to the Firs, producing a growth of entirely different character according to the plant on which it grows? And yet, thanks to DE BARY and others, in Germany, and to PLOWRIGHT, particularly, in this country, the fact has been proved to demonstration by the process of inoculating the tree with spores of the fungus from the other plant and *vice versa*. Fortunately, vegetable physiologists are not hampered by the misguided anti-vivisectionists and so the truth can be more readily arrived at. Considering, on the one hand, the injuries to which plants are subject from insects, squirrels, frost, wind, friction of branches, or mischievous boys; and considering, on the other hand, the enormously great production of fungus spores, the wonder is, not that trees are attacked, but that disease is not far more prevalent than it is.

With reference to the Larch, Professor WARD considered that the prevalence of the disease in some districts of this country, as contrasted with its relative infrequency in its native Alps, is really due in great measure to the fact that we, in this country, all unwittingly, put the Larch under conditions more favourable to the growth of the fungus than to that of the tree. It was disquieting, too, to learn that the Douglas Fir, to which we are looking as one substitute for the Larch in certain situations, has its enemy in the shape of a mould or Botrytis, which may be as fatal as the Peziza on the Larch."

Saltness of Cocoanut Milk in the Sunderbuns.

Have any of our readers who have travelled in the Sunderbuns, found that the Milk of Cocoanut trees in villages in and around them is salt?

In *Nature* for November 5th, 1891, Mr. W. B. Hemsley, reviewing two German works on coast vegetation, says, on the authority of Mr. C. B. Clarke, that in such localities the 'Milk' is so salt as to be undrinkable.'

Grass Farming at Allahabad.

“ About the most difficult administrative military problem the Government of India has had to solve of late years, has been the grass supply of the army. Strategic reasons for the distribution of troops have had to be set aside in consequence of the dearth of fodder in certain cantonments.” So wrote, in 1885, the late Major-General Sir Herbert Macpherson to whose initiation is due the establishment of grass farms in Indian cantonments. The scheme initiated by him in 1882 has been attended with marked success in those localities where it has been carried out on the lines laid down by him ; in other places it has resulted in more or less failure, the reasons for which will be detailed later on.

There cannot be any doubt that the supply of grass and fodder in sufficient quantity and at a reasonable cost for the army in India, is a question of immense importance to the military authorities. The only wonder is that the subject has not engaged the serious attention of the responsible authorities more systematically than appears to have been the case. Efforts have, we know, been made, from time to time, to cope with the difficulty ; but these would appear to have been of a more or less spasmodic character, without any well-recognised or definite plan. The requirements of the army have been met by the old-fashioned contractor system, which has invariably resulted in filling the contractor's pocket to an inordinate extent, without any corresponding advantage appreciable to the Government. But everything has its day, and let us hope that the contractor is an institution of the past, so far at least as the supply of grass and fodder is concerned ; and if every large cantonment were worked on the system adopted at Allahabad, Sir Herbert Macpherson's idea would ere this have been fully realised.

Reading over a memorandum written by Sir H. Macpherson in 1885, “ On the experimental cultivation of grass for forage on cantonment land at Allahabad,” it occurred to me to pay a visit to the grass farm, with a view to ascertain what measure of success had attended the undertaking so strongly advocated by that officer, and I was considerably astonished at the progress made and results obtained, of which the outside public know very little. It may, therefore, be of interest to record here what has been done, what is now being done, and what may be expected in the future, with such suggestions as have occurred to me for the consideration of the responsible authorities.

Under the old system, grass-cutters belonging to Native Cavalry and European Artillery stationed at Allahabad, used to be sent out to cut grass wherever they could find it. These grass-cutters trespassed on lands belonging to cultivators, and carried away grass without payment. Very often this was resented by

the villagers, who forcibly objected to being defrauded of their property, and the feuds were the source of endless troubles to the civil authorities. In referring to this phase of the grass-cutter system the late Sir H. Macpherson wrote ; "They are virtually 'stealing what is the property of the zemindar or ryot ; and even ' in those cases where the ryots have no distinct claim, their ' common ' right is interfered with, as the village cattle have probably ' fed on the lands from time immemorial." This has all been changed now so far as Allahabad is concerned, for while the ryot or zemindar is left in peaceful enjoyment of his 'common' and other rights, the Government has removed one fruitful cause of irritation "between a most deserving class of the native population and the servants of Government" (to quote Sir H. Macpherson), with considerable advantage to the State exchequer, as will be shown presently.

The Allahabad grass farm was started under some difficulties, owing to some local opposition (which was expected) and with small beginnings ; but this was soon overcome, and the working of the first three years showed a clear profit to Government of Rs. 25,000. It was calculated that were the grass scheme to be introduced into every Indian cantonment, and worked as successfully, it would result not only in a supply of fodder for Government cattle being a certainty all the year round, but effect a saving of twenty lakhs of rupees in the military expenditure in five years. From the year 1882-83 to 1889-90 the savings to Government at Allahabad alone, amounted to Rs. 1,13,000, after deducting the cost of Government transport used. There are in all 23 cantonments, and were each of these to record a saving of even one lakh, the State would be now the richer by 23 lakhs of rupees; so that the estimated saving of 20 lakhs in the military expenditure, calculated by Sir H. Macpherson, was not by any means an extravagant one.

The success of the Allahabad grass farm has been maintained, for during the year 1890-91 its operations were extended. The Alfred Park was rented for Rs. 1,800 ; 500 acres at Bargarh (on the Jubbulpore line) for Rs. 200, and the two encamping grounds at Mufti-ki-Purwa and Jhusi, for Rs. 210 ; thus increasing the annual rent paid by the farm from Rs. 14,789 to Rs. 17,000 ; and the total area farmed was raised to nearly 3,000 acres, which yielded no less than 3,25,821 maunds of green grass, which actually cost Rs. 36,881, including rent and all miscellaneous charges, the actual value of which was Rs. 85,470, or a clear gain to Government of Rs. 48,588, as compared with Rs. 32,593 in the preceding year. Of the total harvest, 1,53,102 maunds were issued to Government cattle as green grass ; nearly 24,000 maunds in the shape of silage, and 41,749 maunds as hay ; leaving a surplus on hand at the end of the year of 10,800 maunds as silage and 10,000 maunds as hay. These figures speak for themselves, but these remarkable results were obtained by the application

GRASS FARMING AT ALLAHABAD.

of sound commercial principles to an undertaking which, had it been left to the tender mercies of uninformed supervision, would certainly have ended in disastrous failure, as has been the case in some of the other cantonments.

The first principle of cultivation is to manure the land and plough it. In Europe and America laying down large tracts in pasture is a recognised system; but it has to be done methodically. Great tracts of what were once considered waste lands have been turned into smiling meadows. Those who remember Allahabad eight or ten years ago have probably not forgotten the miles of arid, glaring, dust-laden tracts which formed the chief feature of the landscape. These have, by judicious draining, bunding, ploughing and manuring been turned into smiling meadows, with a luxuriant growth of vegetation. As to the sanitary effects of vegetation, it has been argued by some that it is one source of sickness. But this is refuted by one the greatest authorities on hygiene, who says: "Herbage is always healthy. In the tropics it cools the ground by obstructing the sun's rays and by aiding evaporation, and nothing is more desirable than to cover, if it be possible, the hot sandy plains of the tropics with close-cut grass."

It was also argued some years back that the grass farm would interfere with private enterprise. Why this should be so is not clear, since under the old system it was the grass-cutters who brought in the forage under circumstances already detailed above. The only private enterprise interfered with is the contractor who, used to lease the cantonment lands at a nominal figure. Moreover, I was surprised to learn that the farm affords employment to some thousands of poor people annually, at a time when work is scarce, and is thus a sort of famine relief during seasons of drought and scarcity. The people of the villages surrounding Allahabad look upon the farm as a source of livelihood.

This year I learn that the farm has arranged to supply fodder to mounted Corps on the line of march, by taking up all encamping grounds in the Allahabad district. So far this arrangement has worked very successfully; but some time is yet necessary to prove the advantages of this new departure. This farm supplies fodder to the following:—The whole of the mounted Corps at Allahabad, comprising one battery of artillery and one regiment of native cavalry; the whole of the Government transport and slaughter cattle, the dairy cows and its own bullocks and horses. In addition to the above it feeds about 110 horses belonging to officers, at Rs. 4 per horse per mensem. So that the farm has actually doubled its capabilities during the last two years—a most gratifying result, which has been brought about by manuring and improving the land, under capable supervision.

I now come to what I consider a most interesting feature of the grass farm, viz., the introduction this year of labour-saving

machinery. I had always believed that labour being so very cheap and plentiful in this country, machinery such as is used in England for mowing and threshing would prove an utter failure. But this belief has received a shock. In April last some moving and harvesting machines, also field rakes, were imported. These have been at work since, the motive power being Commissariat bullocks. The natives have 'tumbled' to the new idea with wonderful alacrity, and so successful have these machines proved at Allahabad, that already their use has resulted in a saving of something like Rs. 8,000, which in itself more than covers the initial outlay on the machines. It is a treat to see the mowers and threshers at work: they demonstrate in a striking manner the value of labour-saving machinery on cantonment grass farms, when properly managed. When the grass is cut and dried it is delivered over to another machine, which turns it out in its final stage, in closely pressed bales of a convenient size for handing, and neatly bound about with stout wire.

The points which suggest themselves for earnest consideration appear to me to be as follows:—(a) the necessity for introducing the Government grass farm system in every cantonment in India. Its success has been amply demonstrated at Allahabad; and the only apparent reason for its non-adoption more generally, seems to be that it has not proved a paying venture at Cawnpore, Rawalpindi, Meerut, and probably some other stations. But this is obviously due to the system not being worked on a properly organised plan. At Allahabad the Generals commanding have taken the most lively interest in the matter; but they could not have carried out the idea with any degree of success were it not for the fact that they have had a most capable man in charge of the farm in the person of Conductor D. J. Meagher, who, in addition to the practical knowledge he possesses of the work to be done, takes the keenest interest in all that pertains to the farm. He moreover speaks the language, and by his tact in dealing with the natives, gets them to share his interest in the farm work. (b) The present committee system of working cantonment grass farms does not appear to be the best. The whole of the cantonment grass farms should be worked by a separate department, having well-defined rules and regulations applicable to all alike, except where it may be necessary to make any slight modifications to suit local requirements and conditions. It seems to me that, as the supply of fodder is part of the Commissariat Department work, the best way would be to place the entire management of cantonment grass farms under that department, which should establish what I may call a Forage Branch, to be under the control of one officer, who should be authorised to conduct all operations under this head. He would select and appoint suitable men as farm overseers, chosen from amongst the non-commissioned officers of the army, who may have some previous experience of farm work. (c) The experiment

at Allahabad having proved a success in every way, it should be taken as a guide for all other cantonments. If a grass farm can be worked with so much profit to Government in one station, there is no obvious reason why it should prove otherwise in others. But as I have said above, the management must be in capable hands, otherwise there is no hope of obtaining satisfactory results.—*Pioneer*.

A Cannibal Plant.

Some years ago, a striking story was published in France, describing a wonderful flesh-eating plant discovered by a great botanist. If we remember rightly, the story recounted how a certain collector discovered a plant of the fly-trap species of so gigantic a size that it could consume huge masses of raw meat. Just as the fly-catching plant snaps up a fly and draws nutriment from the fly's dead body, so this one fed itself on the legs of mutton and sirloins of beef which were thrown into its ravening maw. The botanist in the story, for some reason, possibly fear of having his plant destroyed as dangerous to public safety, keeps the existence of the plant a secret, and preserves it in a locked-up conservatory. His wife, however, who is made miserable by his absorption of mind—he thinks of nothing but how to feed and improve his wonderful and fascinating plant—determines to follow him. This she does, accompanied by an old school-friend of the husband. When the pair reach the inner conservatory, they see, to their horror, the infatuated botanist tossing bleeding joints of raw meat into the huge jaws of a giant fly-trap. They are at first petrified with horror. At last, however, the wife throws herself into the arms of her husband, and implores him to give up dwelling upon the horrible carnivorous monstrosity which he has discovered and reared. Unfortunately, however, the wife in appealing to her husband goes too close to the plant. Its huge tentacles surround her and then proceed to drag her in, and the two stupefied men see the plant begin to devour its victim. Fortunately, however, the friend catches sight of an axe lying near, and seizing this he strikes at the roots of the plant. A few frenzied blows do the necessary work, and the flesh-eating plant tumbles to the ground and releases from its clutches the terrified woman. The botanist, however, cannot survive his most cherished discovery, and with the exclamation. "You have killed my plant!" he falls back dead.

The story is good enough as a story, but if we are to believe an article said, in the *Review of Reviews*, to be taken from *Lucifer*—we say "said" advisedly, because we have looked in the October *Lucifer* and can find no such article, and therefore presume there must be some mistake—it is only another instance of fiction being prophetic, and anticipating scientific discovery.

According to the article quoted by Mr. Stead, there has been discovered in Nicaragua a flesh-eating, or rather, man-eating plant, which for horror is quite the equal of the novelist's imagination. This plant is found, it is asserted, in Nicaragua, and is called by the natives "the devil's snare." In form it is a kind of vegetable octopus, or devil-fish, and is able to drain the blood of any living thing which comes within its clutches. We give the story with all reserve, but it must be admitted to be circumstantial enough in all its details to be possible. It appears that a Mr. Dunstan, a naturalist, has lately returned from Central America, where he spent two years in the study of the plants and animals of those regions. In one of the swamps which surround the great Nicaragua Lake, he discovered the singular growth of which we are writing. "He was engaged in hunting for botanical and entomological specimens, when he heard his dog cry out, as if in agony, from a distance. Running to the spot whence the animal's cries came, Mr. Dunstan found him enveloped in a perfect network of what seemed to be a fine, rope-like tissue of roots and fibres. The plant or vine seemed composed entirely of bare, interlacing stems resembling, more than anything else, the branches of the weeping-willow denuded of its foliage, but of a dark, nearly black hue, and covered with a thick, viscid gum that exuded from the pores." Drawing his knife, Mr. Dunstan attempted to cut the poor beast free; but it was with the very greatest difficulty that he managed to sever the fleshy muscular fibres of the plant. When the dog was extricated from the coils of the plant, Mr. Dunstan saw, to his horror and amazement, that the dog's body was bloodstained, "while the skin appeared to have been actually sucked or puckered in spots," and the animal staggered as if from exhaustion. "In cutting the vine, the twigs curled like living, sinuous fingers about Mr. Dunstan's hand and it required no slight force to free the member from its clinging grasp, which left the flesh red and blistered. The gum exuding from the vine was of a greyish, dark tinge remarkably adhesive and of a disagreeable animal odour, powerful and nauseating to inhale." The natives, we are told, showed the greatest horror of the plant, which, as we have noted above, they called the "devil's snare," and they recounted to the naturalist many stories of its death-dealing powers. Mr. Dunstan, we are told, was able to discover very little about the nature of the plant, owing to the difficulty of handling it, for its grasp can only be shaken off with the loss of skin, and even of flesh. As near as he could ascertain, however, the power of suction is contained "in a number of infinitesimal mouths or little suckers, which, ordinarily closed, open for the reception of food." "If the substance is animal, the blood is drawn off and the carcass or refuse then dropped. A lump of raw meat being thrown it, in the short space of five minutes the blood will be thoroughly drunk off and the mass thrown aside. Its voracity is almost beyond belief."

The story is unquestionably a very curious one, and we may rely upon it, that if the plant really does exist, we shall soon have a specimen at Kew. The digging of the Nicaragua Canal will bring plenty of Americans and Englishmen into the very country where the "Vampire Vine" is said to exist, and the question whether the whole thing is or is not a hoax may very soon be tested. This fact makes, we readily admit, very much in favour of the truth of the story. Since the shores of the Nicaragua Lake are soon to be explored, it would have been far safer for a botanical practical joker to have "seated" his plant in that natural home of unverifiable strange stories, the Upper Valley of the Amazon. The neighbourhood inhabited by that Amazonian tribe who, by the use of some secret process, can reduce a human corpse to a tenth of its original size, and so produce a perfectly proportioned miniature mummy of the dead man, would have been a good locality in which to "place" the tale of the cannibal plant. Again, Nicaragua is within the Tropics, and plant-life there is therefore specially gross and vigorous. Besides, there is no inherent impossibility in the idea of a flesh-eating plant. It is merely a question as to whether evolution has or has not happened to develop the fly-eating plant on a sufficiently large enough scale to do what is related of the Vampire Vine. No one who has seen the ugly snap which that tiny vegetable crab, Venus's fly-trap, gives when the hairs inside its mouth are tickled by the human finger in the way that a fly would tickle them by walking, can doubt for a moment that the development of a plant capable of eating or sucking the blood of man, is only a matter of degree. Even in England, there are plants which act on on a small scale exactly the part asserted to be played by the Vampire Vine,—for example, *Lathræa squamaria*, the toothwort, "a pale chlorophyll-less parasite found in British woods." The account of the plant given by Mr. G. A. Thomson in "Chambers' Encyclopædia," is as follows:—"Excepting the flower-stalk, the stalk is virtually underground; it bears suctorial roots and tooth-like leaves. The latter are hollow, and are entered through a narrow aperture by many kinds of small animals. These seem to be entangled in protoplasmic exudations within the leaf-cavity, find exit impossible, die, decompose, and are absorbed." Even more remarkable is Mr. Thomson's account of the carnivorous proclivities of the butterwort. This plant secretes "a copious viscid acid secretion to entrap its victims." "This serves as 'insect-lime;' but, besides retaining the unwary midges, it finally digests them. Drops of rain may fall on the leaves, or pebbles may land there, but without noteworthy effect; a small insect, however, stimulates a copious flow of the fatal secretion. But there is also movement; for, when an insect is caught, the margin of the leaves slowly curl inwards for an hour or two, thus surrounding the booty, or shifting it nearer

the centre, in any case exposing it to more glands. After digestion, the results and the surplus exudation are absorbed, leaving finally the undigested skin of the insect on the more or less dry leaf-surface." It will be noted that this, in miniature, is almost exactly the process adopted by the Nicaraguan carnivorous creeper. If the species of insect-eating plants were very few in number, and were very sparsely found, it might be possible to regard them as mere *lusus naturæ*. There are, however, known to be several hundred dicotyledons which, in some way or other, catch and live on animal food. From such a basis the evolution of a giant and man-eating dicotyledon is within the bounds of possibility. We cannot help hoping very much that the story of the Vampire Vine will turn out to be true, for if it does, the botanists will be able to try some very curious experiments as to how these vegetables which are half animals, digest, and whether their movements can properly be regarded as muscular movements. It is true that Darwin administered extremely homœopathic doses (000095 of a milligramme) of nitrate of ammonia to a sundew, and found the plant responded to the drug exhibited; but it would be far easier to conduct experiments on a larger plant. Even as it is, we know that the insect-eating plants secrete not only an acid, but a "peptonising ferment" for the purposes of digestion. They also feed, like animals, "on substances at a high chemical level." More than a hundred and fifty years ago, Linnæus noted that the Lapps "used the butterwort for curdling milk, a property due to a rennet-like ferment which the plant has in addition to the digestive or peptic." Again, we are told that Dr. Burdon Sanderson has "detected electric currents similar to those observed in the neuro-muscular activity of animals." The borderland between animal and plant life occupied by the insect-eaters is, indeed, one of the most curious and interesting fields of biological study; and if a plant as large as the Vampire Vine could be obtained to experiment with, discoveries of enormous importance to science might very likely be made. The Vampire Vine would doubtless stand a grain of calomel after a heavy meat meal without damage or annoyance.—(*Spectator*.)

Tombak

Is a narcotic, which is known under the name of *Nicotiana persica*, and is cultivated in Persia exclusively, in the provinces of Shiraz, Kechan, and Ispahan (says a writer in the *Kew Bulletin*). Its quality varies with the place of production. The best tombak is that which is derived from Shiraz. The production of this province varies between 1,500 and 2,000 bales a year, which is almost entirely consumed by members of the Imperial family. Tombak of this superior quality is not very abundant and the

price paid for it is about 50f. or 60f. the oke, the oke being equivalent to 2·8lbs. avoirdupois. The province of Kechan produces the second quality of Persian tombak. With small leaves like the Shiraz tombak, the product of Kechan is not even so abundant. The province of Ispahan is the centre of the product for exportation. Its cultivation is carried on on a large scale, and the plant which has a large leaf, forms the third quality of Persian tombak. It has been vainly endeavoured to grow this plant in other localities of Persia and Turkey, and experiments which have been made in growing Shiraz tombak in the districts of Ispahan and Kechan have not been attended with successful results. This is attributed to the quality of the soil. Tombak, which is used in the same way as tobacco, is cultivated in a manner almost identical with that followed in tobacco cultivation. The seeds are sown in the month of May, and as soon as the young plants have attained a height of from 15 to 20 centimetres they are watered once a fortnight. The harvest takes place in September or December, when the leaves are cut and spread upon the ground where they are exposed to the dew for a period of 48 hours, and to this exposure they owe the fact of their being slightly stained with little black patches on the leaves. When carried to the warehouses the leaves are piled one upon the other. A slight smoking to which they are subjected in the warehouses gives to the leaves a greenish tint. The warehouses are then carefully closed so as to exclude all air, and at the expiration of a fortnight the leaves are sorted and packed. In the latter operation the following is the method employed. After having separated the leaves one by one, they are placed one upon the other, and pressed in bundles of from 40 to 42 okes. They are then wrapped in pieces of American cloth, which are stretched and sewn up in the form of bales, called torba. These torba, which are covered with sheepskins, half dressed, are then ready for delivery to the trade. Tombak in good condition packed in bales and warehoused in places not too dry, may be kept without any deterioration for several years.—(*Indian Agriculturist.*)

VI. TIMBER AND PRODUCE TRADES.

Churchill and Sim's Wood Circular

of December 3rd, 1891.

EAST INDIA TEAK.—A good delivery of 1,020 loads in November, against 882 loads in November last year, and 1,080 in November, 1889, brings the consumption for the first eleven months of this year to 13,341 loads, against 15,382 loads, and 14,320 loads respectively, in the same period of 1890 and 1889. A great jump in the price of what floating cargoes are still available, is the consequence of a drought in Siam, which has caused an almost total cessation for the present of the arrival of timber in the shipping ports of that country. Holders of the wood here are therefore very firm, believing that a considerable period of time must elapse before this trade can resume its usual course.

SATINWOOD, EAST INDIA.—Logs are in good demand, the small parcel recently landed realized high prices, and further supplies are needed, but for *planks* and *boards* there is scarcely any enquiry.

EBONY, CEYLON.—Good wood is asked for and would sell well, but lower qualities, of which present stock chiefly consists, are difficult to clear. **EAST INDIA.**—The stock is moderate, demand quiet, and sales small.

ROSEWOOD.—There is a fair demand and moderate imports could be placed without difficulty.

Price Current.

Indian Teak	per load, £9-10s. to £15
Cedar, Malabar	per sup. ft. 3½d. to 4d.
Satinwood, Indian	per ton £8 to £12
Rosewood, Indian	£8 to £12
Ebony, Indian	£10 to £12
Boxwood	£4 to £13

LONDON PRODUCE SALES

December, 1891.

Cutch, fair to fair dry	...	per cwt.	24s. to 32s. 6d.
Gum Arabic, Madras, Dark to fine
pale	15s. to 50s.
Myrabolams, good and fine, pale	11s. to 13s.
Nux Vomica, good	11s. to 13s. 6d.
Sandalwood } logs ton	£35 to £60
} chips "	£9 to £30

VOL. xviii.]

[No. 2.

THE
INDIAN FORESTER ;
A MONTHLY MAGAZINE
OF
FORESTRY,
AGRICULTURE, SHIKAR & TRAVEL

—>◆◆◆<—
EDITED BY

J. S. GAMBLE, M.A., F. L. S.,

CONSERVATOR OF FORESTS, AND DIRECTOR OF THE
FOREST SCHOOL, DEHRA DUN.

—>◆◆◆<—
FEBRUARY, 1892..

—>◆◆◆<—
MUSSOORIE.

PRINTED AT THE MAFASILITE PRINTING WORKS.

—
1892.

Contents.

No. 2—FEBRUARY, 1892.

	Page.
I.—ORIGINAL ARTICLES AND TRANSLATIONS.—	
<i>A tour through Kamraj-Kashmir (Part 2)</i> J. C. McD.	41
<i>The Tortrix of the Teak tree, by J. N.</i> ...	46
<i>Famine and the forests of Bellary</i> ...	48
<i>Forest petitions in Ganjam</i> ...	50
<i>Kashmir products by B. P.</i> ...	51
<i>The ferns of Pachmarhi and those of Mahendragiri,</i> <i>by J. S. Gamble</i> ...	55
<i>Obituary—Mr. F. C. Henvey.</i> ...	58
II.—CORRESPONDENCE.—	
<i>A Forest Department 'Blazer'; letter from T.</i> ...	60
<i>False quantities in botanical names; letter from</i> <i>A. W. Lushington</i> ...	60
<i>The Thana Working Plans; letter from A Divi-</i> <i>sional Officer</i> ...	61
III.—OFFICIAL PAPERS AND INTELLIGENCE.—	
<i>Review of the Report of the Imperial Forest School</i> <i>for 1890-91.</i> ...	61
<i>Articles on forest products for the Board of Trade</i> <i>Journal</i> ...	63
IV.—REVIEWS.—	
<i>Annual Report of the botanical and afforestation</i> <i>Department in Hongkong for 1890.</i> ...	64
<i>Progress Report of Forest administration in</i> <i>Jodhpur for 1890-91</i> ...	65
<i>Progress Report of Forest Conservancy in Ceylon</i> <i>for 1890</i> ...	66
<i>Indian Museum Notes Vol. II. parts 1 to 4</i> ...	67
<i>Report on the Department of Land Records and</i> <i>Agriculture, Burma for 1890-91</i> ...	68
<i>Report on the Canal Plantations, N.-W P. for 1890</i>	69
V.—SHIKAR.—	
<i>Another last tiger by S. E.-W.</i> ...	70
VI.—EXTRACTS, NOTES AND QUERIES.—	
<i>Collecting Mosses</i> ...	72
<i>The Indian Forest Service and its founders</i> ...	73
<i>Casuarinas</i> ...	76
<i>Forest of Box</i> ...	76
<i>A curious find in a Walnut Tree</i> ...	76
<i>Utilization of Grass in Reserves</i> ...	76
<i>Elephant-catching operations</i> ...	77
VII.—TIMBER AND PRODUCE TRADE.—	
<i>Churchill and Sim's Wood Circular of</i> <i>January 1st, 1892</i> ...	79
VIII.—EXTRACTS FROM OFFICIAL GAZETTES	

THE
INDIAN FORESTER.

Vol. XVIII.] February, 1892. [No. 2.

A Tour through Kamraj—Kashmir.

(Continued from last issue.)

No. 2

At Duabgah is the State Hop Garden ; as yet only a beginning has been made, so that this year there will be no profit but it is expected that as the area is extended there will be a large surplus. Hop growing was originally started at the place years ago by the Murree Brewery Co., but various complications arose and the land was thrown out of cultivation. The Settlement Department has now taken the matter in hand, is working it vigorously and hopes to make it a source of revenue to the State. A difficulty is experienced in the supply of hop poles : hitherto, young deodars of 18 to 20 feet in height and perhaps 30 years old, have been cut, but it is manifest that this cannot continue. Without seeing a single forest it is possible to show this : here we have a country in which for ages past no restrictions have been imposed on the cutting of trees ; the village houses are mostly log huts in each of which from 200 to 400 deodar trees are used, so that it is quite evident there can be no forests that require thinning, seeing that the villager, being allowed to take what he liked, would naturally cut that which was easiest to carry, this of course meant young trees suitable for hop poles. This was so patent to me that when, this year, I was asked to supply 50,000 more young deodars, I felt perfectly certain without leaving Srinagar that it could not be done without ruining the forests ; and, having seen the tracts in question since then, I find I was well within the mark, for the forests are well-nigh ruined as it is. The long poles of *Parrotia* are now to be used for the hops and there is little to object to in this as long as they are taken in moderation and from places whence they cannot be brought in as firewood to Srinagar. Here we have one instance which shows the urgent necessity that exists for a proper system of forest conservation in Kashmir : had matters still been as of yore, it is not impossible that as the area of land under hops was extended ; a year or two hence, perhaps, a lakh of young deodars would have been cut for hop poles !

Leaving Duabghah the Viji Nala was next visited; this is the last valley below Srinagar from which supplies of these stout firewood logs are brought out. The march was a short one to the village of Pánjal and being our first outing in the District everything was of interest. There is no made road but our way was along footpaths, sometimes over a grassy undulating country and through pretty little villages embosomed in apple, pear and other fruit trees, with here and there a giant chinar; then would come acres of rice fields and this was not so pleasant as the path was very wet and the ponies were ever and anon slipping into the muddy fields. As the morning wore on, it became very hot and we were very glad to arrive at our camp pitched on the bank of a pretty brawling stream, under a huge walnut tree which completely shaded the tent from the sun. The Viji Nala is among the the most picturesque of the small valleys in Kashmir: there is no open plain as in the Lidan or Lolab but the hills on either side are very low, and being well covered with trees, the view up the valley is very fine; in the foreground is the dancing water rushing over boulders and from among the pretty grey green willows and dark walnut trees on the banks, peep here and there charming little homesteads; while in the background is the dark green and blue of the great Kazinág range. These low hills of the Viji Nala were originally covered with dense kail and deodar forest, mostly the former; but, as cultivation has advanced and the demand for firewood for Srinagar has increased, the forest has been gradually cleared off and towards the lower end where the ranges of hills merge into the plains, there are only a few kail trees dotted about near and in the fields. As the valley is ascended, more forest is seen but the first compact block is not met with till the village of Pánjal is reached. This forest is known as Gujar Nár; it was thoroughly explored. It is evident from the stumps and general condition that this was once a fine forest of mixed deodar and kail with a good quantity of other species such as *Parrotia*, walnut, elm, *Celtis*, *Rhus*, &c., in the ravines, but it is now a wreck. It would be difficult to suggest any form of forest injury that has not been perpetrated here. The most common form is that of barking the trees near the ground: a strip about four feet long is taken off completely encircling the tree so that it dies in a year or so; after barking, a fire of grass, leaves, &c., is lighted at the foot apparently to smoke the surface and make it appear that the injury is an old one. This is partly the work of villagers who use the bark for roofing *machans* in fields, &c., and is also the work of the village *mochi* who requires the bark for tanning. Many thousands of fine kail and deodar have been killed in this way in Kashmir. Another form of damage is that of hacking into the trunk for torchwood (*jagni* in Chamba, *lashi* here) and it is peculiarly exasperating to a forester to see a grand kail or deodar with a deep hole cut into it simply to supply a villager with perhaps one winter's torchwood. In one part of this forest

every kail had been barked after which fire had been applied to the grass and undergrowth so that nothing remained but a number of dead blackened poles ; other trees have had huge holes cut in them for the extraction of resin (*ganda baroza*) and some had holes made merely to hold up the supports for logs to be squared, &c. There are ash (*Fraxinus floribunda*) in fair quantities in this forest but not one can be found that has not been pollarded for the supply of winter fodder for cattle. As there has been no restriction on felling, except that a year ago an order was issued that nothing under 6 foot girth should be cut, which order has, it is to be feared, commanded little obedience, nearly everything has been cut. First went the young poles used by the villagers for building, then the trees of small girth as being easiest to cut and finally anything that would yield a supply of firewood and could be easily got at. There is a standing order that no village is to cut any trees for building without written permission ; little attention is paid to this and several men were caught redhanded, one having felled no less than sixty young kail about 2 feet in girth to repair his house, their one answer when caught is *bé khabar* !

It was quite evident that even the wreck of this forest would not escape unless something was done at once, and as this forest is valuable by reason of its proximity to the line of export, it was at once demarcated with pillars and a ten foot boundary line cleared round it. It is possible that in the course of years it may become a valuable forest, as it still contains a number of fine seed bearers on the crest of the ridge. A good deal of opposition was experienced from the villagers while the demarcation was being carried out : they objected to any culturable land, whether covered with trees, or not, being included in the forest ; their claim was that they had always been accustomed to clear what land they liked for cultivation and could not exist unless this was continued, they were asked where they would obtain timber for building, and firewood when all was cleared, and replied that God would provide it ! This is merely mentioned to show what a difficult task is before the Forest Department in Kashmir. One thing that must be altered is the method of house construction, at present where the village is near the forest, the houses are built entirely of young trees : sides, ends, floors and roof trees are all formed of poles, with a thatch on top. In this way over 200 young deodars have been counted in an ordinary sized house, while some of the large ones have used up as many as 400 young deodars ; no forest, however extensive, could long stand such a strain.—Where there is no forest at hand, houses are built of sun-dried bricks bound together with beams here and there to withstand the shocks of earthquake, and this system must be adopted everywhere if any forest is to remain to the State.

In strong contrast to the treatment of other trees is the care the villagers take of the walnut : whether in a village or forest, not a leaf is touched and no injury is ever done to the bark

though this is very valuable for tanning, but then the walnut is a source of income to the villager and he is wise enough for this. In fact the walnut trees are one of the sights of Kashmir, for numbers, size and luxuriant growth they are probably not to be excelled in any country in the world, and among the chief beauties of this valley are the the park-like groups of Walnut in the greater number of villages.

Very few ferns are to be found in the Viji Nala, the principal ones are several varieties of *Lastrea Filix-Mas*, L.; *Lastrea Thelypteris*, Desv.; *Diplazium japonicum*, Thunb; and one which is possibly *Athyrium McDonelli*, Bedd. if so, it is one of the commonest ferns here, growing with *L. Filix-Mas* in shady or damp places in great luxuriance, individual fronds being 4 feet long and over. Should it be this fern, it is surprising that it was not found here and described before I first came upon it in the Bhandal Valley in Chamba. There are a few other ferns here but nothing out of the common.

From Pánjal our next march was to Kitar Daji in the Hamal Valley. After crossing the Viji stream the path ascends over a low range of hills and through a lovely forest of almost pure kail and to the ordinary traveller there would be nothing but admiration but alas for the forester! his eye cannot help noting the grievous injuries done to the forest he passes through and this was no exception; trees barked, hacked and lopped were to be seen on every side and in the very centre was a Goojur hamlet but lately established and already making its baneful presence felt as was evidenced by the dead trees outside the small patch of cultivation. Still, there are some fine compact blocks of forest here, and there is yet time to save them from the enemy. This is a very fine valley both for forests and landscape, the stream traversing it being of large size and one which evidently has a great volume of water when at its highest. Above Kitar Daji are some very pretty bits of forest scenery and these I explored for ferns very soon after I arrived, several species were obtained here, *Athyrium nigripes* Mett. of large size, *A. thelypteroides*, Michx. very fine and *A. Filix-femina* var. *dentigera*, Wall or *attenuata*, Clarke. The next morning was spent in an exploration for several miles up the valley by a path which eventually crosses over the range into the Kishanganga side. This path ascends very gradually partly through forest and then over grassy slopes till about 7000 feet elevation when the valley becomes narrow and there is forest on both sides almost entirely of spruce and silver fir and yew. Cultivation and its attendant destruction to the adjoining forest has been left behind but though the former ceases, the latter does not; higher up a Goojar hut was reached tenanted by one family only and yet no less than ten large silver fir were found, just outside the hut, barked only a short time before to roof in a wretched shanty which will collapse with the first fall of snow. Next year, if not prevented, this man will bark another lot of fine

trees to make another shanty and so it has gone on for generations past. Is it to be wondered at that the forests are gradually disappearing in this country? Great numbers of mushrooms were found on the grassy slopes and a grand supply taken back to camp where they were much relished on toast and in stews, &c. Some very large specimens of *Cystopteris fragilis*, Beruh, over one foot long were gathered on the banks of the stream. There being no friendly walnut tree in this place the tents had to be pitched in the open and it was quite surprising to find how hot it can be in the vale of Kashmir at this time of the year. Mosquitoes also are a great plague towards evening and curtains are quite indispensable. A specimen of "Kuth" (*Saussurea Lappa*, Clarke) was brought to me here: this is a very mysterious root, for I can find no one who knows for certain the uses to which it is put. The Kashmir State exports large quantities to Bombay but the demand is an intermittent one; some years every maund is bought up, then for two or three years none is sold. From enquiries I have made, it would appear that in Kashmir, at any rate, it is used medicinally, one account is that in China it is used in making joss sticks, another, that it used to be called *Aplotaxis auriculata* or *Aucklandia Costus* of Falconer and in an old edition of the Calcutta Pharmacopœia it is called *Costus arabica* of the ancients, and is said to be exported to China as a narcotic in lieu of, or together with opium; evidently it requires working up, for the Kashmir Revenue when it comes is a large one. I am surprised that I never heard anything of it while in Chamba, it surely must grow there as well as in Kashmir. After leaving Kitar Daji we passed through the Mawar valley which is a jaghir of Raja Amar Singh, this contains some very fine forests and is a lovely country to travel in; the village of Karil is especially pretty; the encamping ground being a level bit of grass shaded by large apple and pear trees. Truly Kashmir is the country for fruit, the pity is that it is so poor in quality, for though every village and even the borders of the forests and fields contain many pear, apple and plum trees, hardly any of the fruit is worth eating; but in time there is little doubt that the traveller will pass through orchards of russets and pippins of sorts and French apples, besides European varieties of the pear, for already, it is believed, arrangements have been made by the Settlement Department to supply plants to villagers. When the Railway is open to the plains, residents of Lahore will probably be able to enjoy as good fruit as they can get in England at a quarter of the cost. At present, even in Srinigar, splendid European apples, that would cost three pence each in England, can be bought for five annas per dozen.

J. C. Mc. D.

(To be continued).

The Tortrix of the Teak Tree.

Every two or three years, Teak trees, more especially those growing in plantations, seem liable to attacks from the larva of a *Tortrix*, which abounds in such numberless strength as practically to destroy the entire foliage of the trees. The most striking of these ravages that occur to me is one that took place in the Kyetpyoogon plantation of the Rangoon Division about 1884, and another in the Pyun Chaung plantation of the Toungoo Division in 1889. In both these cases, the entire foliage was destroyed in April and May, shortly after the flushing of the spring leaves. The leaves were perfectly denuded of all their soft cellulur tissue containing the chlorophyll by means of which the circulation and assimilation of the sap are accomplished, and only the bare skeletons of the leaves were left uneaten, and these withered and fell in the same manner as if they had been shed after normal accomplishment of their intended task. These ravages of the *Tortrix* (*Tectonae*?) are really of very considerable importance. From April till July, when the summer flush of leaves comes, the increment in growth is lost almost entirely, and the later increment of the year must to some, and in all probability to a considerable extent, have been affected by the denudation of leaves previously.

The occurrence of these attacks and details as to their magnitude do not yet find a place in our Annual Reports, although in all likelihood they do as much (or more?) harm than a fire, unless the latter passes through plantations where the accumulation of débris is great. The details are entered in the reserve journal in a general sort of way if the reserve journal is properly kept, and it may, perhaps, be incidentally mentioned in a divisional annual report, but there the record ends, and the objectionable caterpillar is never mentioned to the local Government or the Government of India.

On changes of Divisional Officers taking place, one's interest in the destructive larva is apt to run down, hence no one has yet, so far as I am aware, made out a list of the years during which any one particular plantation has suffered severely. By such means we might arrive at a correct estimate of the period of complete generation, which would have a scientific interest, but which would be of no practical use, it is to be feared. At any rate in Europe they have not been able to apply any practical measures for obviating or even minimising the ravages of *Tortrix viridana* on the oak, or *Tortrix podana* on young growth of Beech.

In Europe the *Tortricidæ* consist of 10 genera and 436 species. The *Tortrix viridana*, which destroys the young spring leaves of the oak, swarms at the end of June and beginning of July, and lays its eggs on the leaf-buds in process of formation after the midsummer flush of leaves; the larva appears in the

following April and May, and enters the chrysalis stage about the end of May or the beginning of June. Its generation is simple ; it is of common occurrence ; *it sometimes appears in large numbers.*

If the generation of our Teak *Tortrix* be similarly simple and annual, (which seems open to very reasonable doubt) how can we account for its occurrences every three or four years in such numbers as to denude large areas of plantations of their spring foliage ? It can evidently not be the result of unsuccessful fire-protection, leaving the poles and saplings in a somewhat debilitated condition, for the ravages are found occurring sometimes after successful protection, and in plantations forty or fifty miles apart, in one of which fire-protection may have been successful, while in the other it was not. Thus, in 1889, when the Pyun Chaung plantations were denuded of their leaves from April till July, similar phenomena, though not quite in such a conspicuous degree, occurred simultaneously through the Teak plantations in the Saing and the Swa.

In the oak forest around Erfurt serious damage was done during four successive years (1869-1872), whilst a similar record is shown for the university forests of Greifswald. Kyetpyoogan is said to have suffered much in 1889 and portions of it have been damaged again in 1890 and 1891. In Europe no active measures can be adopted against *Tortrix viridana* : Hess, one of the highest authorities on the subject, can only recommend the preservation of birds which feed on grubs, and adds "in regard to its destruction hardly anything can be done."

The European species which attack the oak and the beech and spend the time of their chrysalis stage either in cracks in the bark or in rolled up leaves attached to the upper branches. Those species however which attack conifers *T. histrionana, murinana buoliana, &c.*) pass their chrysalis state either in flimsy cocoons spun at the base of twigs, or else on the ground. Thus : *Tortrix murinana*, which attacks the silver fir, after continuing its work of destruction on the needle-like leaves from April till June, lets itself down to the ground by a cobweb-thread-like emission, and enters the chrysalis state on dead leaves covering the soil ; about a fortnight later the small butterfly appears as a perfect insect.

This is exactly what takes place in the case of our *T. Tectonæ* ; about the end of May in going through plantations that are leafless from their attacks, one can see thousands and thousands of the caterpillars working their way down to the ground on delicate cobweb-like threads proceeding from the leaf-skeletons forty to seventy feet over-head. *T. murinana* is therefore evidently the European variety which interests us most and in regard to which we can learn something of use. The measures adopted to prevent and destroy it are :—

Prevention.

- I. Mixture of the silver fir with other trees, and attention to clearing, weeding and thinning.
2. Protection of its enemies (birds).

Destruction.

1. Smoking out of the larvæ by burning green branches during damp weather in May.
2. Driving swine into the forests during the first half of June, when the chrysalis are on the ground.
3. Removal of the dead leaves from the soil during chrysalis stage.
4. Cutting out of trees badly attacked.

With our system of fire-protection, therefore, we appear to be doing our very best to foster and propagate this pest of our Teak productions ; this is the first conclusion that can be drawn from what has been said above. The second conclusion, and from a practical point of view the more important, is that our pure plantations of Teak are not, perhaps, so well adapted to the requirements of nature as mixed plantations would be, and the question may well be raised whether, or not, to a very much greater extent than at present, *Improvement fellings* in carefully selected Teak producing localities might not, to a great extent, take the place of our planting operations, as combining the advantages of a more natural treatment of the Teak with a diminution of the danger from this insect enemy, whose interference with the development of our plantations has not hitherto, in my opinion, received sufficient attention. That the *Tortrix*, however, does not spare Teak trees in a mixed crop, or even isolated trees, has been observed this year in the Kaugyi reserve of the Tharrawaddy Division.

J. N.

Famine, and the Forests of Bellary.

We extract the following from the 'Madras Mail' quoted in the 'Indian Agriculturist' of 26th December, as likely to be of interest. It shews clearly that, especially with such enlightened officers as Mr. Robert Sewell, the present Collector of Bellary, the policy which was inaugurated by Sir M. E. Grant-Duff under the advice of Sir D. Brandis of enlisting the sympathies of Madras Revenue Officers in the work of Forest Conservancy, has had excellent effects.

"The cattle, of course, are badly off, and had it not been for the grazing available on the Sandur Hills thousands upon thousands would have died. With reference to cattle mortality, Mr. Sewell has some very sensible remarks to offer. He thinks

‘ that “ little can ever be gathered from general statistics which
 ‘ show only number of deaths or increase of the number observa-
 ‘ able of half-starved or miserable animals, for the reason that
 ‘ most stock-owners have far too many animals, and they take
 ‘ no pains to stall-feed the old and useless ones, but drive them
 ‘ off to pasture as they can; and it is amongst these that the
 ‘ scarcity of fodder makes itself first felt. But their death is
 ‘ really a relief to the owner, and is often positively a gain instead
 ‘ of a loss. Ploughing cattle and the better kind of domestic
 ‘ cattle are stall-fed, and it is the loss of these only that is really
 ‘ serious.” Further on he adds:—“ I should mention that I am
 ‘ doing my best to avoid the necessity of throwing open the forest
 ‘ reserves. If the reservation is to be any good at all—if the
 ‘ whole theory is not fallacious—we are, in this district, of all
 ‘ others, in need of increasing the annual rainfall by increasing
 ‘ forests and tree-growth in every available locality, and to throw
 ‘ open the forests is to condemn all young growths to utter des-
 ‘ truction. The herdsmen, as I have myself seen, strip the trees
 ‘ of every leaf (and therefore kill them), break down the saplings,
 ‘ and ruin all hopes of successful growth for many years to come.
 ‘ It may seem very hard-hearted, but I care little for the class
 ‘ of old and useless cattle previously alluded to, and want only to
 ‘ secure the stall-feeding of ploughing and useful domestic
 ‘ animals.”

It would be well if some of our North Indian Collectors would make similar practical personal observations to those made by Mr. Sewell: except occasionally for Shikar they seem rarely to enter a forest and never to take an interest in its improvement. The Sandur Leased Forests contain, usually, a magnificent supply of fine fodder grass, but they also are badly in want of rest to allow the tree-seedlings to come on, and it would be the greatest of pities if they were allowed to be overrun by poor, almost useless herds, while a little management would admit of the cattle being fed on cut fodder. We are very much pleased to see Mr. Sewell advocate, what the Madras Forest Officers have long advocated, the clearest of distinctions being made between the valuable well-bred domestic cattle which are used for ploughing, for well-work, and for draught; and the miserable undersized weak herds whose only use is to give manure, most of which only serves for fuel, and to provide, when they eventually die, hides for export. We hope Mr. Sewell's views will meet with approval by the authorities and be adopted elsewhere, wherever possible, and tend to encourage the ryots to improve the quality of their stock and by restricting miscellaneous breeding, maintain only the animals which are really useful, the great benefit of the forests and of the pasture supply of the country.

Forest-petitions in Ganjam.

We recently gave some extracts from the 'Madras Mail' with the text of extracts from an address to the Governor of Madras from the people of Hospet in Bellary, with his reply. The following similar extracts from a petition presented to Lord Wenlock in November 1891 by townspeople of Berhampore in Ganjam may also interest some of our readers. The address said:—" Whilst we readily admit that the conservancy of Forest is ' a matter of prime importance, we beg to point out that the fees ' now levied by the Forest Department are very excessive and are ' pressing very hard especially on the poor and on the ryots. The ' fee formerly charged on a cart load of bamboo thorn was four ' annas; but now it has been raised to Re. 1-4-0 and the result ' is that the ryots find it impossible to properly fence their fields ' against cattle trespass. So with regard to dry fuel, the seigni- ' orage has been raised at one leap from four annas to Re. 1-4-0 ' a cart load, and in consequence the poorer classes often eat food ' that has not been properly cooked. So grievously do these ' measures press upon the poor that we feel we cannot too strong- ' ly urge upon Your Excellency's attention the need for a speedy ' revision and material reduction of these rates. Closely connect- ' ed with these matters is the loud complaint of the ryots about ' the insufficiency of pasture. They say that most of the avail- ' able Government waste land is being demarcated and reserved ' without sufficient regard to the urgent need of pasture lands for ' the ryots' cattle. So much of the District's welfare depends on ' the ryots' cattle being in a fit condition, that we beg that Your ' Excellency will give this matter your favourable consideration."

Lord Wenlock replied as follows:—" As regards the hard- ' ships resulting from the carrying out of the forest laws and rules, ' no doubt it is difficult for those who pay fees to thoroughly ' appreciate the fact that their payment is desirable in their own ' interests; but it is the bounden duty of Government to protect ' the forest and to improve the pasturage of the country, and in so ' doing it endeavours as far as possible to minimise the resulting ' hardships and to raise or lower the fees prescribed with due ' regard to the resources of the payers and to the character of the ' season. I trust that in future, pasturage may be provided at ' almost nominal rates; but at present you are paying but one ' pie per load of grass, a fee of which it is hard to complain. ' These are times when even this might be advantageously re- ' mitted. Its payment, however, as a rule, ensures pasturage for ' the better cattle in years of drought. In such seasons the older ' and less useful animals no doubt suffer, but it would be the first ' duty of Government, when all head of cattle cannot be saved, to ' endeavour to keep alive those which are absolutely necessary to ' the cultivator. In respect of seigniorage rates levied on bamboos,

‘ the general rate sanctioned by Government is Rs. 1-4, but the
 ‘ Collector has the power of reducing it and he exercised this
 ‘ power and reduced it to 8 annas, whereupon the Board of
 ‘ Revenue finding that this District did not contribute its fair
 ‘ share to the expenses of forest conservancy, and that a higher
 ‘ rate might reasonably be levied, raised it to Re. 1, and I must
 ‘ remark that private owners charge considerably more, and that
 ‘ Government must obtain at least a reasonable return.”

That it is not only the Governor and the officials in Madras that hold strong opinions on the necessity for a firm and continuous forest policy, is clear from the following newspaper extract.—
 “ *The Forest Laws*.—From the proceedings of the National Congress on their third day we see, says the *Madras Times*, that a motion was advocated earnestly entreating the Government to mitigate the harshness of the forest laws. We sincerely trust that Government will do nothing of the sort, for while we sympathise with the people on whom the sins of their fathers have been visited, we cannot in justice to posterity urge that the punishment should be lightened, for it is not a whit more severe than the occasion needs, and has already been delayed for some decades too long. Lord Wenlock has spoken more than once admirably on this subject.”

The ‘harshness’ complained of lies in the rates which are charged under order of Government for produce removed by purchasers, not from the Reserved Forests but from the Reserved and Unreserved Lands. To any one who may think these rates very ‘harsh’ we suggest a careful examination of them. It would not be easy to make them much lower than they are and rightly are. We doubt if the native gentlemen who prepare these addresses really themselves have ever gone into the question—the paragraphs, we suspect, are only too often suggested for insertion by some one directly interested not in the supply of the villagers so much as in the trade in forest produce.

Kashmir Products.

The products (minor forest produce) alluded to in the Kashmir Report (*Indian Forester*, September, 1891) are interesting and some of them, if not all, easily identifiable.

Two sets of products are noticed :—

(1) Those of the upper or temperate hill forests : (2) those of the hotter, lower-hill forests about Jamú.

1. Banafsha or violet, is well known : the flower is dried and is said to be diaphoretic, also said to be laxative. The species is given as *Viola serpens*, the root (bekh-banafsha) is said to act like ipecacuanha. In the Hazára hills I have found a dark flowered violet, beautifully scented. Stewart notices this as *V. Patrinii*, DC.

2. Kahzabau (Káh-or gáo-zabán—'Co π's tongue', from its rough leaves), the flowers, leaves and roots are all used. It is said to be imported from Afghanistan. The flowers sent to the Punjab exhibition were cuttings of *Boraginææ*, perhaps *Anchusa* sp. or *Onosma*. The root called "Ratanjot" is used for dyeing red: various plants are probably collected under this latter name.

3. Bibi-dána: are the seeds of the quince: is this wild anywhere? The seeds are mucilaginous when boiled. In Europe, hair cosmetics (bandoline, &c.) are made with them. Demulcent, cooling.

4. Zíra: the traveller in the hills must have noticed this yellow-flowered umbellifer. *Carum Carui* (or *C. gracile*) is the black zíra or caraway. Safed or white zíra, is cummin, *Cuminum cyminum*: this is said to be wild on the N. W. frontier, but does the writer not mean *Bupleurum marginatum*, the seeds of which are also aromatic?

5. Guchhiári, are those shrivelled dry 'morels' which are strung together on a coarse string and sold in the bazars in Kashmir. Dr. Cooke found, in a string sent to him, two species—one he named *Morchella deliciosa*, and the other *M. gigaspora* nov. sp.

6. Kooth (Kúth) is the strong-scented root which is used to preserve shawls from moth, and is, or used to be, always packed up with bales of shawls and woollen goods from Kashmir. (*Aucklandia Costus* or *Saussurea Lappa*.) It is said to be largely exported to China for use as incense. It is noted as a monopoly of the State; that is, the Court has the right of buying from the collectors all the produce at a fixed rate. The books distinguish two kinds of kúth (as applied in medicine) one called 'shírín, or sweet, the other 'talkh', or bitter.

7. Kour (perhaps for Kúr not Kaur?) some kind of root is meant apparently. *Holarrhena antidyenterica* is called 'Kawar' in some places, also Kúrá; but it is the seed and bark of the small tree that are used, so that something else must be meant; perhaps *Gentiana Kurroo?* or a valerian?

8. Dharékari: (this appears to be drisikarí or dresikari also called egilbír or Akalbír.) A yellow dye root, for silk chiefly; root of *Datisca cannabina*.

9. Malin: as no accent is used, it is impossible to say what is meant, Málán? or Malín? or Malíu? (both short) Stewart mentions a Kashmir root (exported, he says) called málín; it is used in a pounded state and applied to abscesses:—this he refers to *Solenanthus* sp. (*Boraginææ*.)

10. Rasaunt is ordinarily a yellow substance obtained by boiling nearly to dryness the juice of *Berberis* sp.: the Reporter says that the product is obtained by boiling the root of Kanbel, this I cannot identify.

13. It is interesting to note that *Sapindus* is used as a source of dandása as well as *Juglans*: the astringent bark is used variously; especially as a tooth cleaner.

15. Unāb, is the Bazar name for the fruit of the Ber (*Zizyphus* sp. var). Surely this name is not used for the wild fruit (Berí, sinjíl in Kashmirí),

17. Dhúp is noted in connection with Kút; and indeed *Dolomiaea macrocephala* is used as *incense* (Dhúp), and grows in places like those where *Saussurea* would be found, at a still higher elevation.

18. Harvi is said to be a poison—evidently a root. It is unknown to me, possibly *Aconitum*?

19. Wild ginger, is too vague for identification; probably “banhaldi” (bazar Kapúr, Kachrí) *Hedychium spicatum* is meant.

20. This gives another name for the Birch-bark on which orders, letters, &c. are written in Kashmir and in Chamba. The bark is used for wrapping and packing: it is noted as a State monopoly: does the writer mean ‘tuz’ or ‘taz’ or túz?

21. Revas (edible) perhaps for riwás or ribás, the shop name for rhubarb stalks, as ‘rewand’ is for the root, (No. 28 of the Report.) The species of *Rheum* are several, in the Himalaya from 6,000 feet to great heights, indeed to the snow line.

22. Bartang (Bártang): is this *Plantago sp?*—and the ísabgol of the druggists’ shops?

23. This I cannot trace.

24. The same:—Kanocha in the druggists’ shops is the seed of *Salvia Moorcroftiana*, or other species said to be useful in dysentery, &c. (called also Kalauncha).

25. Werch, is referred to *Acorus Calamus*: it is an aromatic tonic: if so, it is a semi-aquatic or swamp plant, with a long branching rhizome creeping in the mud. Further enquiry is needed: there is some doubt whether an *Iris* root is not meant.

26. Afímun, is the same as ákás bel, the *Cuscuta reflexa*, well known as a pest on trees.

27. Kasús, is really (as found in druggists’ shops) in part the seed of this same *Cuscuta*; both these names are shop or official terms, not local.

28. Ravand (Réwand or Revand) is the rhubarb root. I believe the Himalayan species are not determined very well: it seems certainly the case, that some species, though giving the pleasant sub-acid stalk (réwás) have no material quality in the root, or only have it in a very inferior degree.

29. Uskhuddus: this is a (perhaps the Report-writer’s, perhaps apopular) corruption of Ustukhádús: which is the official name of a drug recognized in the Yunání medicine practised by Hakíms. It affords a curious substance of what is often observable in Hakíms’ drugs. The Yunání medicine is simply copied through Arabic translations from the old Greek writers. Now these latter had a drug, *Lavender*, or *Lavandula Stoechas*, but the (Arabic) Ustukhádús is merely a “juggle” of the Greek Stoikhas (Stoikhades, inflexed). All the specimens we examined were *Prunella*

vulgaris, which grows freely all over the hills: it is quite inert and of course possesses some of whatever virtues the aromatic *Lavandula* has. But the Indian Hakíms were bound to find local plants to fit in with the *rough descriptions* of the plants in the Greek medicine books. How rough they are may be seen by reading the "Mahiyat" or essential features of the drug plants as given in such authorities as the "Makhzan-ul-adwiya" &c. Lavender was widely described as a *spike*, with a distinct calyx to each floret and a lilac or purple hooded flower; and this, as the *Lavender* does not flower in India, is referred to *Prunella* which now is found in druggists' shops as *Ustukhádús*. Many other drugs of European origin, in the Greek books, have these Indian substitutes found for them, owing to rough similarity of form, without the remotest reference to properties or efficacy!

Turning now to the products of the Jamú (lower) hills.

1. A'mila (ámila or *aoínlá* is the well known acid semi-transparent fruit of *Phyllanthus Emblica*, fancifully called 'emblic myrabolam,' because so often used in native medicine with the two "myrabolans" (*Terminalia Chebula*, and *T. Belerica*). The three are pounded together as an astringent, with or without salt, to form "triphadá"—the three-fruit compound.

2. Balela or Bahera, *T. belerica*.

3. Halela or har, and harar, *T. Chebula* } The nut or fruit.

4. Amaltás: the well known long (black when ripe) cylindrical pod of *Cassia* (or *Cathartocarpus*) *Fistula*: it is purgative.

5. Shell-lac (sic) does not grow on any tree: crude lac is the product of an insect puncturing the bark of ber and other trees and it is made into *shell-lac* by melting and straining through cloth when liquid (and thus removing impurities): it is allowed to drop and spread out on broad pieces of plantain stem (Khelá) to which it does not adhere, and then dries. Then it is *shell-lac* or purified lac. Or rather '*shell-lac*' is applied in Europe to still further refined lac: it is, I believe, dissolved in spirits and evaporated, forming thin sheets which break up into little bits like shells.

6. and 7. Need no remark.

8. Is "Kishta" *unripe* peach and wild apricot dried: used in dyeing, and to clean silver (for which it is first rate—the silver article is covered with a sticky paste or soap made of kishta and water and then heated hot in a charcoal fire.)

10. "Gillo" is found in the shops as "Sat-giló"; i.e. the fecula of the root collected and dried. Stewart says, the "dry-extract:" to me it looks like collected powder or fecula. *Tinospora cordifolia* (*Cocculus*, DC)

11. Harmal: the drug so called is abundant on waste broken ground in the plains: at one time the seed was used in Europe in dyeing a peculiarly "Sienna" brown, known some years ago as "Bismarck brown." Curious superstitions exist among natives about burning the seeds to drive away evil-spirits. (*Peganum Harmala*) (*Rutaceæ*)

12. Bil-kath, or Kath-Bel. (wild Bel) is *Feronia Elephantum* or perhaps *Aegle Marmelos*, which is cultivated as the bēl or "bael" fruit. *Aegle* is, I understand, found wild also.

14. Māl-Kanganī. The red seed of the large shrub* (hardly tree) *Celastrus paniculata*, given to cattle, as also to men for rheumatism; an oil is got from the seeds, and used both internally and externally for the latter complaint.

15. Wawring, (Wá-warang, Wai-warang, also bé-barang.) referred to *Myrsine africana*: the berry of the shrub is anthelmintic (ripe in October). The bebrang" of the medicine book is called "*Embelia Ribes*" but this is not an Indian species, at least not in the Panjáb. A similar name appears to be given to the seeds of another plant, also anthelmintic *Rottlera tinctoria* (tree called Kámila or Kaméla)

16. Taj—is a name for cinnamon bark; and here, I suppose applied either to *Cinnamomum albiflorum* which occurs in the Himalaya (Stewart) or some *Cassia*?

17. Medásak: is the bark of *Tetranthera Roxburghii* pounded and wetted with milk, &c., and applied to contusions.

18. Baroza, (often ganda-biroza) is the crude resin or turpentine (not gum) of chíl (*Pinus longifolia*).

19. Chalwá (or Chilwa) is the seed of the Chíl pine. Is this used for food?—It is not meant, I suppose, to refer to the chilghoza or edible seed of *Pinus Gerardiana*.

As to the fruits said to be wild. What is meant by Apples: are these wild (edible) Crabs? The wild pear is perhaps kaint (*Pyrus Pashia*). Sour grapes (sic), what are they? I found wild grapes in Kághán quite edible, small, black and sweet, are they originally wild? Is there any Plum (*Alucha* or *Prunus*) wild? Peaches are practically wild in parts of the hills, so are apricots.

Oxford, Nov. 1891.

B. P.

* No.'s.—Climber, Hon. Ed.

The ferns of Pachmarhi and those of Mahendragiri.

While at Saharanpur lately, I was looking over some interesting collections made by Mr. J. F. Duthie in the Hills of the Central Provinces; and being particularly struck by the number of interesting ferns which he had found, which I should not have expected to have occurred in that locality, I asked him for a list of his collections. He has, consequently, kindly supplied me with the following:—

- Gleichenia dichotoma*, Willd.
Cyathea spinulosa, Wall.
Alsophila glabra, Hook.
Davallia tennifolia, Sw. var. *Chinensis*.
Adiantum caudatum, L.
 " *Capillus-Veneris*, L.
Cheilanthes farinosa, Kaulf
Pteris longifolia, L.
 " *quadraurita*, Retz.
Asplenium heterocarpum, Wall.
 " *esculentum*, Presl
Nephrodium calcaratum, Hooker var. *ciliatum*.
 " *falcilobum*, C. B. Clarke
 " *cochleatum*, Don
 " *sparsum*, Don
 " *molle*, Desv.
 " *cicutarium*, Baker
Nephrolepis cordifolia, Presl
 " *exaltata*, Schott
Polypodium multilineatum, Wal.
 " *lineare*, Thunb.
Acrostichum appendiculatum, Willd.
 (*Note.*)—Pinnæ of barren frond all acuminate
 caudate instead of blunt. Pinnæ of
 fertile frond very long (C. W. Hope)
 " *variabile*, Hooker
Osmunda regalis, L.
Lygodium pinnatifidum, Sw.
Angiopteri evecta, Hoffm.

In all there were 26 species. Pachmarhi lies at the highest point of the Satpura Range, in latitude about $22\frac{1}{2}$ degrees N. and longitude $78\frac{1}{2}$ degrees E. and the species of greatest interest among those enumerated are the *Acrostichum appendiculatum*, the huge fleshy *Angeriptions evecta* and the two tree ferns *Cyathea* and *Alsophila*. It was also interesting to find the flowering fern *Osmunda regalis* and the *Gleichenia*.

A few years ago, I paid a visit to a very interesting mountain on the East Coast, 4,500 feet high and only ten miles from the sea, off the little Port of Barwa in Ganjám. The mountain is known as Mahendragiri and it lies in the territories of the Raja of Mandasa. It is, like Parásnath, a celebrated Jain place of pilgrimage and the temples alone are interesting and are fully described in Professor V. Ball's "Jungle Life in India." But the botany is extremely interesting, for on Mahendragiri, seem to meet the North and the South, the Himalaya and the Nilgiris. It is a matter of the greatest regret that I have not kept any list of the plants in general; but as, on my return to Chicacole, I met Mr. E. Sewell C. S., then Sub-Collector, and I found Mrs. Sewell

had collected ferns also on Mahandragiri, I drew up the following list of thirty four species found on the mountain.

- Gleichenia dichotoma, Willd.
- Cyathea spinulosa, Wall.
- Alsophila glabra, Hook.
- Davallia tenuifolia Sw. var. Chinensis
- " pulchra, Don
- Adiantum caudatum, L.
- " lunulatum, Burm.
- " Capillus-veneris, L.
- Cheilanthes tenuifolia, Sw.
- " fariosa, Kaulf.
- Pellæa concolor, Langs. and Fisch.
- Pteris pellucida, Presl
- " quadriaurita, Retz
- " aquilina, L.
- Blechnum orientale, L.
- Asplenium laciniatum, Don
- " crinigerum, Bedd.
- " drepanophyllum, Baker
- " oxyphyllum, Hook.
- " esculentum, Presl
- Nephrodium cochleatum, Don
- " sparsum, Don
- " molle, Desv.
- " unitum, L.
- " cicutarium, Baker
- Nephrolepis cordifolia, L.
- " exalta, L.
- Polypodium multilineatum, Wall.
- " lineare, Thunb.
- " membranaceum, Don.
- " fissum, Bl.
- Hemionitis arifolia, Burm.
- Lygodium pinnatifidum, Sw.
- Angiopteris evecta, Hoffm.

It is worth mentioning that a year or two later, I found further south, on the Rumpa Hills, *Lindsaya ensifolia* and *Nephrodium pteroides* with mostly the same other species as the above list. Mahendragiri lies at about 19 degrees North latitude and 84½ degrees East longitude and its slightly more southern latitude accounts for the presence of such otherwise wholly southern species as *Pellæa concolor*. It is noticeable that we did not find *Osmunda regalis* or the two stream-loving *Nephrodia*. Possibly, the time of year, (March) when it is hot and dry on the East Coast, was against us.

J. S. GAMBLE.

Obituary—Mr. F. C. Henvey.

The news of the sad accident at Jalpaiguri which resulted in the death of a promising and popular young Forest Officer, Mr. Henvey, reached us just too late for our January number which had gone to Press already. We might even then have found means to give an account of it, but have been waiting for a promised report giving the details. As that report has not yet reached us, we cannot do better than republish the following from the *Englishman* :—

Jalpaiguri, *January 6.*—As the enquiry into the late lamentable accident up here has been held, and Mr. Shillingford entirely exonerated from all blame, and as there are still various versions of the story going round, I think I should tell you briefly how it all occurred.

Mr. Henvey and Mr. S. J. Shillingford were spending the night in a tent near the forest (Wednesday night, 9th December): shortly before midnight some Paharias came to tell them that the rogue elephant was feeding in some *dhan khets* some $\frac{1}{4}$ to $\frac{3}{4}$ of a mile away. Although Mr. Shillingford tried to dissuade Mr. Henvey from going, he insisted, and at last both went, and as a matter of fact, saw the elephant feeding in a "tongue" of khet, on the further side of which was heavy forest (I have personally examined the place,) and on the side where they were standing there was a high bank covered with jungle and the land above this had a little cultivation, a good deal of sun grass and some jungle. There are two well beaten tracks leading up the bank from the khets, some 120 yards apart—one leading up to a village, and the other (the northern one) to the waste land. Mr. Henvey wanted to stalk the elephant in the khets, but Mr. Shillingford absolutely refused to allow him to do so. The natives suggested that they should go with torches to the forest side of the elephant and drive him up towards the bank, when he would certainly take one of the two tracks, as he had done before when driven in the same way. Mr. Shillingford agreed to this, and posted Mr. Henvey at the southern or village track, and himself, at the northern, thus standing 120 yards apart with their backs to each other. The natives did as they had promised. Mr. Shillingford saw the elephant come towards him, and disappear into the deep shadow at the foot of his track. Shortly afterwards there was a rustling and movement of the jungle by the track which Mr. Shillingford and the natives naturally thought was the elephant. The natives whispered "Fire, fire!" and at last began to bolt, Mr. Shillingford himself retiring a few paces. As the movement came nearer, at last in the excitement he fired, and almost immediately heard a European cry out, "My God!" and running down found that he had shot poor young Henvey in the thigh.

Mr. Henvey, notwithstanding the remonstrances of the natives, who absolutely refused to go with him, had gone alone down his track, wandered along the *dhan khets*, passing, we must suppose, close to the elephant, and was making his way up to Mr. Shillingford's track when the accident occurred.

Everything was done that was possible to stop the bleeding. He was put on a plank stretcher and carried to the tent, while after infinite trouble and large promises men were sent off to the neighbouring gardens and the European doctors. Two native doctors were soon on the spot. Mr. Macgillycuddy, of Sathkhya, went down with coolies, etc., and Mr. Henvey was carried to that garden. The European doctors who lived some miles away were on the spot by eight, but even then the bleeding had gone on so long that the case was nearly hopeless. Mr. Henvey got weaker, and quietly passed away at 12-40 P. M. on Thursday, just twelve hours after the accident, conscious almost to the last. It is gratifying to know that he repeatedly assured Mr. Shillingford that the fault lay with him in leaving his place without waving.

The poor fellow's remains were interred in the Planters' Cemetery at Rangamatti on the 11th, Friday, and were followed to the grave by nearly fifty Europeans.

The Cemetery is in a corner of the Rangamatti Garden, walled in and kept in good order by the Europeans living near. I may here mention that neither of the gentlemen had ever been in the day time to the place where the accident occurred.

We are glad to be able to add to the above sad account the following extracts from a letter from Mr. Dansey, Conservator of Forests in Bengal.

Henvey joined the Service in January 1891, passed the Higher Standard in Hindustani in April and was about to appear for oral Examination in Law and Land Revenue. In the written test he had obtained very good marks. He was only 21 years old and did not look so much, not that he was at all puny, but because he was one of those rosy, smooth-faced youngsters. He was in every respect a nice young fellow, nice-looking, well mannered, fond of society and social pleasures, yet withal well up in his profession, industrious and promising well. He was also a manly young fellow, good at tennis and anxious to distinguish himself in all manly exercises, particularly so with his gun. In him, the Department has experienced a more than usually severe loss. Personally, I had only met him on a few occasions, but the impression he had made on me was such that the news of his death come upon me as a great shock.

 II. CORRESPONDENCE.

A Forest Department 'Blazer.'

DEAR SIR,

A short time ago I wrote to you suggesting a Foresters' "Blazer" and you were good enough to agree and also made what I think a good suggestion for the colors themselves, viz. dark blue with a red border and an I. F. S monogram surmounted by a crown on the pocket. Presuming this pattern to be accepted there will still be a variety in the monogram, the breadth of edging or the tones of the colors themselves unless either there is some firm appointed to make these "blazers" (e. g. Harry Clark & Co. at Mussoorie) or the above points are somehow clearly described in the "Indian Forester." Perhaps also it would be as well in some way to ascertain whether a sufficient number of officers cared for the idea before *fixing* this as *the* "blazer" of the Department. Remains the question what grades should have the right to wear the coat or rather, the colors, for I presume the usual adjuncts of tie, cap, and so forth, would be obtainable if wanted.

Yours truly,
T.

Note.—Some objections having been raised to the use of the letters I. F. S. (Imperial Forest School) by the Dehra Dún students, because the same letters may stand for other things, the School will probably alter their badge to D. D. F. S.

Hon. Ed.

 False Quantities in Botanical Names.

SIR,

I should like to bring to your notice an expression in M. Mathieu's "Flore Forestière" which is capable of giving a wrong idea.

Speaking of maples, he says:—

"Le nom d'acer (fort), fait, dit-on, allusion à la qualité du bois des érables." (The name Acer, strong, given to maples is said to allude to the quality of the wood of the maple.)

Now the word *acer*, a maple, has no connection with *ācer*, strong, as the school Latin Primer tries to explain in its line:

Est ācer in sylvis: Equus ācer Olympia vincit.

The maple exists in woods: the strong horse wins the Gymkhana!

There are words that are homographs in all languages, such as the word "gallant" in English; with the accents different, the meanings are different.

A. W. LUSHINGTON.

The Thana Working Plans.

SIR,

In various recent articles in the *Indian Forester* we have all observed with wonder and awe numerous references made to the Thana Working Plans, with its 300 odd Working Circles, and I am sure most of us are now on the tip-top of expectation to hear more of this marvellous document.

For my part I should especially like to know how it is going to work with regard to the preparation of Code Forms, Nos. 23 and 36, as the work which such a complicated arrangement will involve will be enormous.

In the Division of which I have the honour to hold charge, a Working Plan's Officer has saddled us with 23 Working Circles, regarding which I was under the impression I had a certain substantial cause of complaint but on hearing of the three hundred and one Working Circles for the Thana Working Plans, I have now decided to retire to the most obscure back seat.

The very idea of such a complication of Working Circles is to me simply appalling, and is sufficient, I should think, to cause the Divisional Clerks to desert "*en masse*" and the Divisional Officer himself to apply for sick leave, or an immediate transfer.

A DIVISIONAL OFFICER.

Note.—We are glad to inform our correspondent that he will not have to wait very long for an account of the Working Plans.

Hon. Ed.

III. OFFICIAL PAPERS & INTELLIGENCE.

Review of the Report of the Imperial Forest School for 1890-91.

At the beginning of the year there were 80 students attending the School: seven left for various reasons, and three, having obtained certificates after a special examination, were posted to their Provinces; so that only 70 were in attendance throughout the year. Of these, 39 were in Government employ, 16 were deputed from Native States, and the remaining 15 were private students.

During the year, 26 students gained the certificate of Forestry by the higher standard. Two of these obtained the certificate as the result of special examinations, which were held in the interest of urgent provincial requirements, and at the request of a Local Government, and 24 in the final open examination, held at

the end of the course and for the first time supervised by the Board of Control. Three certificates with honours were granted, to Upendranath Kanjilal of Assam, and to B. Hira Singh and C. Appaya, both of Mysore. Twelve students received the certificate of Forestry by the lower standard; one in consequence of a special examination; three who failed in the examination for the higher standard by less than 10 per cent.; and eight at the final open examination for the lower degree. One student obtained the lower certificate with honours.

The Governor-General in Council approves of the proposal made by the Board of Control that in future the entrance examination for the Forest School should be held at convenient educational centres under the supervision of officers of the Educational Department. His Excellency in Council requests that Local Governments will give practical effect to the arrangement laid down in the alteration of the school prospectus in regard to this matter.

The Resolution of the Board of Control in regard to the standard of instruction to be adopted, the subjects to be taught, the order to be followed in the instruction, the courses of instruction and syllabuses of the courses, the teaching by Divisional Officers, and the time-table of studies, is also approved of by the Government of India.

The Board of Control supports the system of periodic examinations and of according marks, which are to be counted at the final examination and the Government of India accept this proposal for the present, subject to a future discussion of the question.

The proposals regarding the final examinations are accepted; but the degree of prominence to be given to each subject at these tests should be further discussed with the view of giving a preponderating importance to Sylviculture, which, under the present proposals, has been placed on a par with Botany. The Government of India also approve of the proposals made regarding the percentage of marks required in order to obtain certificates.

It is observed that a "certificate with honours" will not in future be awarded to any student who fails to obtain half marks in any subject. This is a very proper condition, but the Government of India further desire that the fact of a candidate having passed with honours in subsidiary subjects only should not be entered on the school certificates. It is noticed that during the last examination every passed student has gained honours in one or more subjects, and the Government of India desire to draw the attention of the Board of Control to the fact that honours cease to be the distinction they are intended to be, if they can be too easily gained.

The Governor-General in Council is pleased to sanction the expenditure of a sum of Rs. 1,000, during the next two years, for

the purpose of completing the stock of books in the school library. As regards the preparation of manuals for the use of students, he will be prepared to take into consideration any definite proposals which may be submitted by the Board of Control.

The Government of India acknowledge the necessity of supplying additional quarters for students, and the proposal made by the Inspector-General of Forests, to add a general mess room for students to the new block of buildings, will receive due consideration. The removal of the present range of servants' quarters is desirable for sanitary reasons ; and the Government of the North-Western Provinces and Oudh, will be addressed with the view of obtaining a site further removed from the main school-block. The proposal to erect a special hospital and dispensary will also be taken into consideration.

Articles on forest products for the Board of Trade Journal.

The following letter has been circulated to the Conservators of Forests by the Inspector-General.

Her Majesty's Secretary of State has expressed a wish that the semi-commercial Departments of the Government of India should, from time to time, collate and prepare for insertion in the Board of Trade Journal, items of intelligence connected with Indian trade and industries, which would be of general interest to the mercantile community in the west. Similar information is likely to be required for the Imperial Institute.

I am convinced that the export trade in forest produce can be largely developed, and that there are many products in our forests the utility of which is as yet unknown, and others in regard to which there is insufficient information with reference to the quantity obtainable and the method and cost of collection. Original enquiries, research and experiments will be necessary to meet our purposes in respect to those articles which it is desirable to bring to public notice, and in this respect I intend shortly to issue a separate Circular soliciting your assistance. But in the meantime I would propose that we should collect and compile information which is already obtainable.

It is desirable that subjects should be taken *seriatim*; and the first series of articles might comprise the history of the sea-borne export trade in timber; the present state of this trade; a forecast of a possible development, as regards species already in the general market; and proposals concerning other kinds which have special qualities and are found in quantities sufficient for the development of a lucrative trade.

May I ask you, with the permission of the Local Government, to favour me, as early as possible, with all the information you can collect as regards the points mentioned above. I would suggest that the subject should be worked up by you in conjunction with one or two specially selected officers (whose names would be duly mentioned in connection with the article), for it is desirable to obtain the information in a well-digested and thoroughly reliable form.

It is my intention to have these articles published if possible in the first instance in the *Indian Forester*, sending copies to the India Office for the use of the Board of Trade Journal and for the Council of the Indian Section of the Imperial Institute.

IV. REVIEWS.

General Reviews.

ANNUAL REPORT OF THE BOTANICAL AND AFFORESTATION DEPARTMENT IN HONGKONG FOR 1890.

This Report, just received, does not contain very much of interest, but at any rate shews that the Hongkong authorities are working well to cover with tree growth as much as possible of available land on the island. The chief tree used is the *Pinus sinensis*, and the area of plantation is, we know, considerable. During 1890, 450 acres were planted and if we assume that a similar area was done in each of the 11 years since planting began, it would give 4,950 acres as the total area already planted up. Besides *Pinus sinensis*, of which 5,16,851 plants were put down, a large number of *Cryptomeria*, *Tristania conferta* and other trees were also planted. The Superintendent expresses the wish that some less formal tree than the Pine could be found and very likely an admixture of broadleaved kinds would be useful in mitigating the effects of the fires, which seem to be sometimes very serious. We quote the following account of them and their causes:

“ Fires were exceptionally numerous and the destruction of trees by them was greater than in any previous year, in fact the reported fires were more numerous than the total number of fires recorded for the previous 10 years. The number of fires recorded in 1890 is 64. After my return from Japan I visited the scenes of fires where trees had been destroyed or damaged, and made a rough estimate of the quantity destroyed, the total number of which is 107,000, varying in size from 1 foot up to 8 feet high. On Mount Davis about 49,000, and on Mount

' Kellet 47,000 trees were destroyed, the remainder, 11,000, were
' in numerous other places scattered over the island. Although
' it is impossible to detect the originators of the fires, except very
' rarely indeed, there is no doubt whatever that the system of
' ancestral worshipping at tombs by the natives is the main, or
' almost exclusive, cause of these fires, no care whatever, apparent-
' ly, being exercised to prevent the fire used from igniting the
' grass. The large burial places on Mounts Kellet and Davis
' were the reason of the exceptionally heavy losses on those hills,
' the smaller losses being also caused by the existence of isolated
' graves in smaller cemeteries near to villages. Nearly all the
' fires took place in October when the autumn ancestral worship
' takes place, and the exceptionally numerous and extensive fires
' were the result of the very combustible condition of the low
' vegetation brought about by the excessively dry weather in
' September and October.

' As remedial measures for the future, I propose, in addition
' to the ordinary precautions adopted of stationing men in the
' vicinity of burial grounds all over the island, to extinguish fires
' which may occur at the spring and autumn tomb ceremonies, to
' post during those seasons notices cautioning the people to
' exercise care in the use of crackers, candles, &c., and to increase
' the number and extent of fire barriers in plantations near large
' cemeteries, so that the plantations will be divided up into
' smaller blocks to which fires that may arise within them may be
' confined. Nothing connected with the origin of grass fires or
' of objects to be gained by them is known which might occasion
' any suspicion that they may have been acts of incendiarism."

PROGRESS REPORT OF FOREST ADMINISTRATION IN JODHPUR
FOR 1890-91.

The *Progress Report of Forest Administration in Jodhpur State for 1890-91*, has reached us from the Superintendent, Lala Daulat Ram Bimbhat. The area of forests now comes to 290 square miles. They are managed under a set of Rules which are given in the Appendix to the Report and which are published as 'durbar orders.' These Rules constitute three classes of forest, viz: 'Protected,' 'Open,' and 'Independent.' The protected forests are closed to the public in the matters of felling timber, and grazing except at certain times of the year; the open forests are open to certain villages having prescriptive rights in them; and timber is cut under departmental superintendence, dry-wood and grazing being free; and the independent forests consist of a block made over to 'Ganerao' in which he levies his own fees. We are not told who Ganerao is. Nor is it clear what the Rules contemplate as 'prescriptive rights,' but we think the term rather a dangerous one

to use as likely to bind future rulers and hamper future management. The rest of the Rules relates to the privileges allotted to different classes of villages and to the rates payable for forest produce.

The most interesting chapter of the Report is that which refers to 'fire protection,' and the success of the measures taken is gauged by the fact of only 12 square miles out of 298 having been burnt. The fires are said to have mostly come from the Oodeypore territory where fire raged everywhere unchecked. In one fire a sad accident occurred, recalling a recent similar report from France, for in a fire on the Oodeypore boundary four women and a man were surrounded and burnt to death.

We note with interest that the pressing of grass for export as hay has been commenced. A 'Boomer Hay Press' purchased from Burn & Co., Calcutta, for Rs. 1,250, was used, and bales of convenient size turned out, but we are not given any information regarding the financial success of the work.

The revenue of the year came to Rs. 20,918 and the expenditure Rs. 10,692 which seems good, considering the large amount of produce given away free.

PROGRESS REPORT OF FOREST CONSERVANCY IN CEYLON FOR 1890.

The *Progress Report of Forest Conservancy in Ceylon for 1890*, has reached us from the Acting Conservator Mr. A. F. Broun. It contains much of interest, but shews that forest matters are still rather unsettled in the island. The area of Forest of all classes on 31st December, 1890, was 1782 square miles, made up of—

	Sq. miles.
Reserved Forest	40
Proposed Reserved Forest	130
Other Crown Forests	1,612

and this area is managed by a Conservator, a Deputy-Conservator, 9 Assistant Conservators, a Superintendent of Railway Fuel Supply and 4 Foresters. Their rates of pay are not given, except that we are told that the Senior Assistant-Conservator gets Rs. 4,000 per annum, the next Rs. 3,500 and most of the rest Rs. 3,000.

The Ceylon Forest Ordinance must indeed be rather a curious one, for the Conservator says in para. 25 :—" A revision of the ' Forest Ordinance is most urgently required. A law which ' makes Forest Officers public servants so as to give them the ' protection of the Penal Code, and yet excludes from its pro- ' visions Forest Rangers, Guards and Watchers who are the pro- ' tective Officers of the forests, and therefore require protection ' most, and a law which does not allow Forest Officers to fell a

'tree without permission of the Government Agent, while the Office Assistant, who has perhaps never set his foot within a forest can do so, must require considerable amendment.'

The descriptions of the forests and their reproduction are rather unintelligible to us, from the use of none but native names. We have not always at hand libraries of reference to enlighten us, so that such names as 'hulanhik,' 'na,' 'wewarana' and 'mibiriya' convey no information. It is a pity that the scientific names could not have been added in brackets for the benefit of the uninitiated. We note, however, that, as in the Nilgiris, the Eucalypti, Anstralian Wattles and some Conifers are being successfully grown in the hills round Newara Ellia and that teak and mahogany are being planted in some places. The Mahogany in the Jaffna District in the extreme north seems to grow well, the oldest tree planted in 1843 and 47 years old shewing a mean girth of 8 ft. 7 inches, which is rather surprising as we always thought Jaffna was a very dry place. But there cannot be much doubt that Mahogany likes being near the sea, as is shewn by the fine trees in Calcutta and Madras.

The results of the years' finance were :—

Revenue	Rs. 5,10,045
Expenditure	, 4,21,517
			88,528
Surplus	88,528

which seems good.

INDIAN MUSEUM NOTES, VOL. II PARTS 1 TO 4.

Indian Museum Notes. Vol. II. parts 1 to 4 contain, as usual, much most excellent work by Mr. E. C. Cotes on the insects destructive to crops both agricultural and forest. In Part I. there is an account of the *Stromatium asperulum*, a cerambycid beetle which attacks Teak in the Kulsī plantations in Assam and is probably the insect described by Mr. A. G. Mein in our pages in 1879. The small moth whose larvæ are so destructive to Toon trees in Dehra Dun is identified as *Magiria robusta*. A weevil discovered by Mr. C. Gilbert Rogers in the seeds of *Strobilanthes pectinatus* at Darjeeling is described as a new species *Apion Strobilanthi*; and the larva found by the same officer on the leaves of the big Darjeeling oaks, *Quercus lamellosa* and *pachyphylla*, proves to be also a weevil though it cannot yet be very precisely identified. There is an interesting account of the American blight, which after having been reported as doing serious harm to apple trees in South India, has now appeared in Mussoorie. It is an Aphid named *Schizoneura lanigera*. And there is a full account of the moth which has been so destructive to Sal trees in the Darjeeling Terai and is now identified as *Eumeta Sikkima*. In Part 3 is an article on 'white

insect wax' made by an insect (*Ceroplastes ceriferus*) which has long been cultivated in China and which has recently been discovered by Mr. W. P. Thomas in the Hoshangabad District of the Central Provinces feeding on saplings of *Terminalia tomentosa* and *Chebula* and *Buchanania latifolia*; and in Chota Nagpore by Mr. Peppé on the mango and *Terminalia Arjuna*. Part 2 gives an account of the wild silk-producing insects of India with a beautiful series of photo-etchings of the different species. These are intended as a supplement to a paper in the 1st Volume of the 'Notes' and we recommend our readers to study them and help in defining their limits and the plants upon which they feed. Part 4 gives an account of the different species of Locust that have, at one time or another, committed havoc in the fields of various parts of India; and shows that there are several species and that it is mistake to imagine that all the swarms belong to one and the same kind.

REPORT ON THE DEPARTMENT OF LAND RECORDS AND
AGRICULTURE, BURMA, FOR 1890-91.

The *Report on the Department of Land Records and Agriculture, Burma, for 1890-91* contains little or nothing of special Forest interest, though we regret to see that the question of the provision of permanent grazing grounds is subject to very frequent fluctuations. It is clearly a waste of energy and trouble for one District Officer to set apart thousands of acres of land as grazing ground; while his successor finds it more profitable to throw them open for cultivation, and yet this apparently is what is going on. We wish that the idea which the Director of Agriculture has of the grazing question in the North-Western Provinces were really true. He says:—"In the parts of India which are most highly cultivated (e. g. the North-Western Provinces) people cannot keep many cattle, but are compelled to stall-feed those they do keep, and the cattle though fewer in numbers are therefore better cared for and are less liable to disease." He would, we think, change his opinion were he to visit with us some of the southern slopes of the Siwaliks of the Saharunpore District a month or two hence, and see the sort of cattle it is that graze and how much stall-feeding they get. And we fancy that all the Sub-Himalayan Districts are in much the same case. The country wants not only a large increase in stall-feeding but a larger growth of fodder crops.

REPORT ON THE CANAL PLANTATIONS
FOR THE YEAR ENDING 31ST MARCH, 1890. (P. W. D. IRRIGATION
BRANCH, N.-W. PROVINCES.)

The Canal Plantations in the North-Western Provinces would form an average Forest Division from certain points of view. They have an aggregate area of 36,037 acres, a gross revenue of Rs. 1,88,196, and an expenditure of Rs. 54,772. The most noteworthy point about them is that they have an excellent market for the produce, hence the high average net revenue per acre of three and a half rupees.

The trees on these canals are counted every year, and in many cases they are numbered and their dimensions, and, we believe, value, entered in a register. What constitutes a tree we are not told, *i. e.* what is the lowest girth recorded, but as given in the Report we find that the number of trees at the end of 1888-89 was 1,858,612; that 186,715 trees were felled during the year, and that at the end of 1889-90, there were 1,771,263 still remaining; this shews on the whole some 99,366 trees entered the plantation, either by being planted from the nurseries, or by growing up above whatever is the minimum size adopted for the definition of a tree. We read in the Resolution "The figures show that the re-stocking of the plantations is not 'keeping pace with the felling, and the matter should receive the 'careful attention of all officers concerned."

Expenditure is incurred on the five major works—the Betwa, Upper Ganges, Lower Ganges, Agra and Eastern Jumna Canals,—on fencing, sowing and planting, watering, clearing and thinning, and conservancy. We gather from the Report, that there are 1269 miles of fencing, but we are not told in what it consists—probably in wire—nor what it costs per mile.

On the Upper Ganges Canal, a sum of Rs. 4,475 was expended in eradicating the jungle along the Canal banks, as it tended to harbour pigs which damaged the neighbouring crops. The Superintending Engineer of the Lower Ganges Canal writes as follows:—

"Hitherto the Bhognipur Division is the only one in which 'special measures have been taken to clear jungle with a view to the 'extermination of wild pig. In the cold weather of 1889-90 the 'effect of the jungle clearance in the few miles above Shikohabad 'was very marked in the way of reducing the number of wild pig 'to be seen on the canal banks; but in April and May the pig 'returned again and might have been seen any evening in '“sounders” of 10 and 12 in low cover close to the water's edge. 'There is usually sufficient cover in the fields outside to shelter the 'pig when that on the canal bank is cleared, and I doubt if any 'measures we can take short of shooting females will exterminate 'the pig. It is probable that if a fraction of the money spent on

‘ special jungle clearance on the Bhognipur Branch had been
 ‘ devoted to the purchase of ammunition for shooting the pig, the
 ‘ practical results would have been much better.

‘ On the Bhognipur Branch between July 1889, and April
 ‘ 1890, the following sums were spent on jungle clearance :—

		Rs.
‘ 1st sub-division	...	2,798
‘ 2nd ditto	...	1,837
Total		3,837

‘ It may be taken that of this sum about Rs. 3,000 were spent
 ‘ on special clearance over and above what would have been ex-
 ‘ pended on ordinary clearance of canal banks and berms. The
 ‘ whole of the branch canal from miles 17 to 106 has been cleared.
 ‘ During the canal closure, 1890, several miles of the berms have
 ‘ been cut, and the earth heaped up above water level on the
 ‘ remaining berm. This operation should reduce the growth of
 ‘ *narkul* to a large extent.”

It is probable that these operations which involve the up-
 rooting of grasses and other plants will favor the growth of
 natural seedlings. Clearances under special grants were also
 made along some of the other canals. But the cost of these
 clearances is very heavy, and they will have to be renewed every
 second or third year. However, the revenue and expenditure of
 the Irrigation Department in the North-West are so enormous
 that a few thousands expended on any special work are but as a
 drop in the ocean.

We should like to know how many trained Forest Rangers
 they have, and whether it would not be a good policy for them
 to send three or four promising young men to the Dehra Dún
 Forest School every year to learn their profession. No doubt
 the plan has been mooted before, but there is no harm in again
 drawing attention to it.

S.

IV. SHIKAR.

Another Last Tiger.

The sun was already low in the horizon on a January eve-
 ning when the writer, followed by a shikari carrying a blanket and
 a spare gun, proceeded cautiously along a cattle track leading
 through scrub jungle to the spot where lay the remains of a
 buffalo, said to have been killed the night before by a large
 tigress. Not much time was lost in climbing into the “*Machan*,”

nor was much needed, for it seemed even in daylight to be unnecessarily low and as the evening advanced it appeared to become much lower! After the quiet departure of the shikari an hour passed in silence uninterrupted save by the noisy crows who closely investigated the kill but declined to alight and taste, a circumstance held to show that the tiger had not yet given up all claim to his supper; then sunset, the exit of the lowing cattle from the forest, the voices of the passing cowherds conversing with the watchers in the distant fields, followed by dusk and a feeling of intense solitude. The buffalo lay under a small tree to the left of an open space, once one of the main entrances to a fort now in ruins; on each side of the "*machan*" the ditch and mound of this fort overgrown with dense jungle were still describable in the evening gloom, for the tree bearing the "*Machan*" grew almost in the ditch and the opposite mound was only a few feet below the level of the ready rifle. The moment for the arrival of the tigress if she intended to pay an evening visit had now come, and that she was in the near vicinity was suddenly proved by the scolding of a solitary monkey who had taken up his quarters for the night not a hundred yards distant; and sure enough after a couple of minutes which seemed an age, a shadowy form was visible to the strained sight but too distant to make it worth while to risk firing when the rifle sights were useless in the darkness. Another few minutes passed and then suddenly, as out of the earth, the outline of a tiger was seen advancing to the kill and only a few feet distant from the "*Machan*." As the rifle was slowly raised, the tigress, evidently suspicious turned her head and looked full at her fate. It was the last I saw of her that evening, the report of the rifle was followed by two angry roars and through the smoke it seemed as if the beast was intent on revenge, for she appeared to rush in the direction of the flash and then suddenly to disappear. It must have been full twenty minutes before the cautious whistle of the Shikari bringing up an elephant was heard, and so home to the cosiness of a camp fire and dinner table, where the chances of to-morrow's search were fully discussed. The next morning early, three experienced trackers covered by the rifles of two howdahs were busy examining the faint marks on the hard soil and translating the story of the previous evening. One or two short hairs and a slight scratch in the ground showed that the tiger had been hit, had fallen or lurched evidently to one side and had then made off at a run into the ditch to the right of the tree. Another 20 yards, covered by inches by the trackers, and blood was found, and then to these men, whose keenness of sight was only equalled by their courage, the work became easy. For hours the tigress was followed over the worst possible country, precipitous ravines, thorny scrub, and dense forest, till a warning growl proclaiming her vicinity, each tracker was in an instant 15 feet up a tree whilst the howdahs eagerly advanced to the prey. But the end was not to be so soon. The

tigress was apparently too sick either to fight or to run far, at every fifty yards she lay down waiting only to move on as the trackers approached, and midday had passed before it was decided to abandon the trail and on the morrow adopt the plan of sending guns ahead to intercept her anticipated path. On the morning of the third day the track was again taken up and it was soon evident that the tiger had remained all night where she had been left the day before; she still refused to face the elephants but by dint of careful driving she was forced into open country where for the first time she showed herself in charging the advance guard with angry roars. Having thus asserted her intention to accept battle, she took up her quarters under impenetrable thorns where she succumbed after repeated attempts to charge and damage her enemies. The tigress was a young animal about 9 feet long with a winter coat in splendid condition. The bullet fired from the "*machan*" from a .500 express rifle had struck on top of the left shoulder but had injured no vital part, once more proving my theory that a hollow fronted bullet in the shoulder of a large tiger does no immediate vital damage, and that the middle of the body is the spot to aim at if indeed aims can be taken. To me this experience of tracking over difficult country was new and specially interesting. I was filled with astonishment and admiration at the coolness and sagacity of the trackers who followed the tigress from the kill to her death with the keenness and fidelity of bloodhounds, and I felt that from start to finish I had enjoyed more true sport than if I had killed half a dozen tigers with a line of elephants.

S. E. W.

VI. EXTRACTS, NOTES AND QUERIES.

Collecting Mosses.

Mr. Duthie is collecting materials with a view to compiling a list of mosses known to occur in North-Western and Central India, and would be glad to receive specimens from any persons interested in the subject. Every kind of moss, more especially fruiting specimens, would be acceptable. After gathering the specimens, all that is required in the first instance is to lightly press them between sheets of absorbent paper in order to remove the moisture, and a ticket should be placed with each kind stating the locality where, and the date when, collected, and the parcel may then be forwarded by sample post bearing, to the Director, Botanical Department, N. India, Saharanpur. Any one wishing to receive the names of specimens contributed by them should retain a duplicate set numbered in correspondence with those sent to Saharanpur.

The India Forest Service and its Founders.

The permanent and progressive improvement of wood cultivation in Scotland will be secured only by the founding at Edinburgh of such a national school of forestry as the Royal Scottish Arboricultural Society is seeking to accomplish. It is high time that Scotland should do for itself what its sons have effected for many other countries. In the whole annals of economic progress and commercial development, it may be questioned if anything quite so remarkable can be cited as the beginning, the growth, and the results of scientific or State forestry in British India during one generation. In thirty years the India Forest Department has been called into existence, has been organised under experts, and has created for the Government a net annual revenue larger than that of France, and soon certain to equal if not surpass that of Prussia. For centuries France and Prussia have enjoyed regular and systematic forest management, seen in well-stocked woods, with a gradation of ages, which yield large annual crops of timber and other forest produce. The annual surplus raised from the French forests is about three-quarters of a million sterling, and that of Prussia is under a million sterling. Even as far back as 1889-90, two years ago, the gross receipts of the forests of India were £1,486,303, and the net revenue £706,268. Upper Burma has been added, and in a few years even Prussia will be distanced by India.

Such a result is due to two Scotsmen—the first (and last) Marquis of Dalhousie and Dr. Cleghorn of Stravithie, long a distinguished member of the Madras Medical Service, who is still spared to us. As a poor Scots peer, the great Lord Dalhousie knew well the value of ancestral trees. Next to roads, forests were the first object of his care in every new province that he added to the Empire. The second Sikh War revealed to his keen eyes the vast plains of the Panjab, “wholly destitute of forest trees,” to use his own official language. Immediately, the order went forth some forty years ago that every district officer should plant and induce the landlords and peasantry to plant trees, so that now the face of the hot plains has been altered, the climate has been ameliorated, and the land has a fine water supply. The next conquest forced on that Governor-General was Pegu. That Province also, soon to be doubled up with Arakan Tenasserim as British Burma, he visited, and its stores of teak and sal timber attracted him. In the Punjab it was the people whom he directly benefited; in Burma he saw the necessity of organising a State Forest Department if the teak treasures were to be reserved and extended so as to meet profitably the necessities of the Empire. For the first Conservator of Forests in Pegu, and ultimately the first Inspector-General of Forests in all India, he went to the University of Bonn, and there found the man he wanted in its Professor of Botany, the son of the great writer on

Greek philosophy, and himself now the better known Sir Dietrich Brandis, Ph. D. That was in the year 1856. But for some time before that Dr. Cleghorn, when marching about with his sepoy regiment, had seen and represented to Government the waste caused by the *Roomri* cultivation, under which the peasants burned down whole forest tracts to form a fertile soil for their sporadic crops. He induced the authorities in South India to listen to him and to adopt his plans. Lord Dalhousie at once appointed him Conservator of Forests in Madras, and afterwards in the Punjab, and there he brought about such results that the Government of India publicly described him as "the founder of forest conservancy," a title the justice of which Inspector-General Brandis was the first to recognize. Scottish ideas and Prussian experience have combined to produce the growing net revenue of three quarters of a million sterling a year, and the far greater advantages to the country and the people, some of which we may describe.

The Forest Service of India was first organised in 1864. The superior officers are selected for it by competition in this country, and are trained professionally with those for the Public Works Department at Cooper's Hill College, or in Germany or in France. The subordinate native officials are specially educated at the Forest School, near Dehra Doon, in the lower Himalayas. It is certainly not creditable to the British Government that its forest officer should be sent to foreign countries for that theoretical and practical instruction which could be so easily and efficiently centralised at Edinburgh, to the advantage not only of India, but of the whole country. In India the Forest Service is so organised that each of the great provinces is under at least one chief officer, styled conservator. Burma, Bombay, and North-West India have three each and Madras has two. Each conservatorship, or forest circle, is divided under deputies or assistants, and each of these divisions is sub-divided into ranges. It is found that an area of 20,000 acres, or 30 square miles, is as much as can be managed by one forest ranger. The life of these officials, while sometimes full of hardship and fever risk, is delightful to the man who knows the language well enough to like the natives, and who is fond of sport. The late Captain Forsyth, son of an Aberdeenshire manse, who too early fell a victim to exposure, produced the most charming record of a cultured forest officer's life in his "Highlands of Central India."

Under careful legislation, the system of Indian Forestry works with little immediate hardship to the peasantry, and with ultimate great gain to them especially in the time of such drought as that which is still desolating large tracts of Madras. Having surveyed all the forest resources of his circle which are not strictly private property, the conservator selects and marks off as reserves an area sufficient to supply to the natives timber, firewood, bamboos, canes, and other produce, and to the State such articles.

of foreign demand as teak, sandalwood, and rubber. Although the State is almost the universal landlord, it buys out or compromises private rights in the reserves. If the Forest Service had done nothing else than stop the yearly fires which used to devastate the woods, and supply an adequate number of seed-bearing trees so as to secure the regular reproduction of the more precious timber, it would have justified its existence. In some cases, by leases, the Government have managed to keep in existence, and to improve, limited areas of private forest ; but these have been too generally exhausted by their thoughtless native proprietors, whom Lord Dalhousie, in the famous Minute of 1856, reviewing his eight years' administration, described as "improvident and ignorant petty potentates."

In the last twenty-seven years, since the Forest Service was organised all over India, an area of no less than 60,000 square miles has been thus reserved and demarcated. Every year this is being increased at the average rate of 2,000 square miles and the whole will certainly rise to at least 80,000 square miles, yielding a revenue of considerably more than a million sterling a year. When Upper Burma was brought by Lord Dufferin under the Empire, it was found that nearly all the best teak forests were worked under leases from King Theebaw. These were investigated and have been equitably settled. The rapid exploration of the few officers who could be spared has revealed some 9,000 square miles of splendid forest, fast being cleared by the most wasteful felling and fires. Of these, some 1,100 square miles, chiefly under teak, have been reserved ; a more limited area, very rich in cutch and teak has been found. In most of the leased forests great numbers of trees have been girdled to be worked out, and everywhere reproduction is being satisfactorily aided on a proper system. In the last year for which we have figures, 1890-91, the total outturn of teak rose from 195,405 tons to 260,074 tons ; half of the latter was extracted by the Bombay Burma Corporation alone, so the export of teak from Burma by sea rose from 156,434 tons to 184,431 tons. But the natural result of this was that the price of teak in the English market fell from £13 to £9 per ton.

Only half a century ago, when the East India Company had its own navy, the famous dockyard of Bombay, with its Parsee shipwrights, used the teak of Western India to turn out what were then magnificent ships. Notwithstanding the now general use of iron in shipbuilding, it is quite possible that the time may come when the natives of India will use their own forests from which to construct their own coasting marine. The British Government is creating for them a rich source of wealth ; but valuable as are the teak and other great timber trees of the Indian forests, we shall see that their humbler products may be so utilized as to prove even greater means of prosperity and happiness to the people.—(*Scotsman.*)

Casuarinas.

A few of these elegant Australian shrubs are grown in our conservatories, and some even form part of the repertory of the table-decorator. Their chief interest, however, is botanical. M. Treub, the eminent director of the Botanic Garden at Buitenzorg, shows that the pollen-tube, instead of entering the nucellus through the micropyle, as is customary, makes its way through the chataza. On this account Dr. Treub has divided flowering plants into two divisions, viz., Porogams, including the Monocots and Dicots, and Chalazogams, comprising the Casuarinas only. The pollen-tube in some cases branches at the end, and the whole course of development of the female flower is different from that of ordinary flowering plants.—(*Gardener's Chronicle*).

Forest of Box.

Near Antkjel may be seen the remains of an old Box-tree forest. This tree is now rare even in the Caucasus; a wood containing about 20,000 trees, ranging up to 2 feet in diameter, still stands at a higher elevation near Bsipp, but has recently been purchased by an English company for nearly one million dollars. A Box forest, says Dr. Dieck, in *Garden and Forest*, is the genuine forest of the fairy tales. "No soul can be so dull as not to feel its influence. Hardly a ray of sun can penetrate its thick roof of foliage; perpetual twilight and solemn silence reigns within it. All the trunks, all the knotted branches, all the twigs are thickly covered with long trails of moss, while the dark soil beneath bears only a rare tuft of Fenus or group of shrinking fungi. No bird's voice is heard, no insect whirs through the air; only the rustling of the tree-tops and the moaning of the wind-twisted boughs breaks the church-yard stillness of this ghostly wood."—(*ibid.*)

A curious find in a Walnut tree.

Whilst a large walnut tree, which had been purchased by Mr. C. Smith, gunsmith, Newark, from Denton Manor, was being sawn at Mr. Jas. Smith's timber yard, London Road, Newark, a curious discovery was made. The trunk was about four feet diameter, and on the saw going down the centre a hole was found about six inches long, full of quicksilver. The hole had at some ancient date been bored out, and the quicksilver inserted and plugged up. The plug, which was made of deal, was found,

and beyond it had grown in the course of time eighteen inches on either side of solid walnut. Considering the very slow growth of walnut, a tree of this dimension must have taken several hundred years to produce, and it is conjectured that the hole could not have been made less than two centuries ago. What was the object of inserting the quicksilver it is difficult to surmise. The tree stood in Denton village, close by the side of the footpath.—(*Timber Trades Journal.*)

Utilization of cut grass in Reserves.

The Collector of North Arcot has issued a most useful and timely proclamation to the ryots of the District asking them to devise means for the prevention of a recurrence next year of the great mortality among cattle. The Collector remarks that the "stalk of paddy straw in the district is almost *nil*, and owing to the failure of one monsoon and deficiency of another, it is not likely that there will anywhere be more than one wet crop this year. Again the area of wet land cropped to date is considerably less than normal. It is, therefore, certain that there will be an insufficient stock of dry fodder for next year, 1892, and unless there should be very good mango showers in April and May, and a good and early South-West Monsoon, the mortality amongst cattle is likely to be repeated." The ryots have been warned therefore to take warning by the past and to take precautions for the future. The means suggested are to cut, dry and stack the grass which grows abundantly at present in the forest reserves, and which would make excellent fodder in the hot weather. Grass is also allowed at present to be cut in all forest reserves free of charge, and permission has also been accorded to stack the dry grass in the reserves till required for use. Revenue and forest officers have been asked to afford every facility to the ryots to cut and stack the grass in the reserves. Mr. Le Fanu's example might profitably be followed in other districts.—(*Indian Agriculturist.*)

Elephant-Catching Operations.

As mentioned briefly by us before, the Government of Madras has decided to allow the Forest Department to continue its elephant-catching operations on the pit-fail system which it has been carrying on in Malabar and Coimbatore since 1884. Though the general system is the same in all cases, the number, size and arrangement of pits vary a little according to circumstances. In North Malabar, Mr. Morgan had opened 13 pits for his first venture in 1884, and these were repaired and new ones added the following year, when more extensive operations were instituted. Having examined the main elephant paths and fords, he pegged out pits 12' by 14' in groups of two to four according

to the lie of the ground, and these he excavated to a depth of from 12' to 14' refilling them to within 7 or 8 feet of the mouth with small springy branches of trees, and over these a layer of bundles of lemon grass. The pits were covered in with a light platform of split bamboos, over which came a layer of grass, and lastly, dead leaves, &c., arranged so as to resemble the surrounding ground. The earth dug out of the pits was either thrown into the nearest stream or strewn over the ground and covered with leaves, &c., to conceal it and avert suspicion. A couple of jungle men were then told off to watch the pits and make a daily report. In South Malabar there are 19 new pits in the nellikutta forest and 22 in the Karunpaya reserve, making, with 164 old ones in the recently acquired Amarampoliem forests, a total of 165. Each pit is 12 feet square at its mouth and 12 by 9 at the bottom. In South Coimbatore similar arrangements are observed. Mr. Porter has dug 21 pits in groups of three within a radius of two miles of his forest station, Mount Stuart, each 12' by 9' with a depth of 10'.

When an elephant is caught, the thing to be done is to get it out of the pit and removed to a kraal, *panthi*, with the least possible delay. In North Malabar there is a large *panthi* at the forest station of Begur about four miles from the pits. It is simply a huge and substantially built cage capable of holding four large elephants at a time. In South Malabar there are five kraals, and in South Coimbatore there are four, two permanent and two temporary. On capture being reported, trained elephants are at once marched to the spot, and the captive being secured by soft ropes is enabled to get out of the pits by means of grass and brushwood which are thrown in, and it is then escorted to the kraal by the decoys. Here its schooling begins. In all cases the rule is to avoid the least unnecessary severity and to train by means of kindness. Men accustomed to the work are employed, and in North Malabar, Mr. Morgan, by a judicious system of rewards in the shape of jaggery, sugarcane or other delicacies, induced the animal to perform various acts of obedience. In a couple of months the elephant is tractable enough to be taken out of the kraal and stabled in the ordinary way, well chained, of course, and in another two months it has learnt to kneel, lie down and obey the word of command. In five months' time it may be taught to drag timber after a fortnight's preliminary training at which it may be sent to work with the other elephant. In South Malabar, Mr. Hadfield makes it a rule to release all elephants, past their prime, as in his opinion, which is shared by Mr. Sanderson, such animals usually pine and die, or, if they survive the ordeal of capture and training, seldom turn out satisfactory. His treatment in the kraal is to allow abundance of fodder only and to pour water copiously over the animals four times a day, which is a great luxury, and which, he finds, not only serves to promote good health, but goes a long way toward making them docile.

Mr. Morgan estimates that the average cost of capturing and training an elephant under the system will amount to Rs. 250, the estimate being exceeded or diminished respectively according as the supervision is careless or several elephants are trained at the same time. As regards the results since 1884, 31 elephants in all have been captured, of which 17 survive. Of the casualties 4 are ascribed to neglect and the remainder to natural causes. These results appear satisfactory enough, and at any rate prove that the pit-fall system properly carried out and properly supervised is neither a cruel nor an unprofitable one. The two essential conditions for its success are carefully dug and furnished pits and daily supervision by responsible watchmen. As long as these are fulfilled there is nothing to be urged against it. Nevertheless, we trust that a careful comparison between the kheddah and pit-fall systems will be made as soon as the Mysore Government has furnished the necessary statistics. Mr. Morgan believes that if statistics could only be obtained they would prove conclusively that the mortality under the former system as now conducted in Mysore is four times greater than under the pit-fall plan. But he probably includes in his estimate the old and useless elephants which Mr. Sanderson himself kills on account of the danger they would become if turned loose again.—(*ibid*)

VII. TIMBER AND PRODUCE TRADE.

Churchill and Sim's Wood Circular.

January 1st, 1892.

The imports of timber into the United Kingdom during 1891 amounted to 6,760,130 loads, valued at £14,479,138. The consumption of London was 32,290,000 pieces, comprising deals, battens, boards and ends; with 196,800 loads of timber railway sleepers and spars. Of *Teak* 16,621 loads were imported. The demand for *Ebony* is increasing, £10 to £12 per ton being ruling rates. *Rosewood* and *Satinwood* are also in good demand.

VOL. XVIII]

[No. 3.

THE
INDIAN FORESTER ;
A MONTHLY MAGAZINE
OF
FORESTRY,
AGRICULTURE, SHIKAR & TRAVEL

EDITED BY

J. S. GAMBLE, M.A., F. L. S.,

CONSERVATOR OF FORESTS, AND DIRECTOR OF THE
FOREST SCHOOL, DEHRA DUN.

MARCH, 1892..

MUSSOORIE :

THE MAFASILITE PRINTING WORKS Co., LIMITED,

1892.

Contents.

No. 3—MARCH, 1892.

	Page.
I.—ORIGINAL ARTICLES AND TRANSLATIONS.—	
<i>A tour through Kamraj-Kashmir (Part 3)</i> J. C. McD.	81
<i>The Classification of Ants, by R. C. Wroughton</i> ...	87
<i>Thana Forests and their Working Plans by</i> G. P. Millett ...	89
<i>The advantage of preliminary practical work in the</i> <i>training of Indian Forest Officers, by J. S.</i> <i>Gamble</i> ...	96
II.—CORRESPONDENCE.—	
<i>The Cooper's Hill Prospectus, a letter from</i> <i>'Forest Officer'</i> ...	99
III.—OFFICIAL PAPERS AND INTELLIGENCE.—	
<i>Rules to regulate appointments and promotions in</i> <i>the Provincial Forest Service</i> ...	101
IV.—REVIEWS.—	
<i>Report on Forest Conservancy in Victoria in 1890.</i>	109
<i>Descriptive List of the Timber trees of the Central</i> <i>Province of Ceylon</i> ...	113
<i>Forest Work in Baluchistan in 1890-91</i> ...	114
V.—SHIKAR.—	
<i>Accident during the Garhwal Kheddus: The end</i> <i>of the rogue elephant</i> ...	115
VI.—EXTRACTS, NOTES AND QUERIES.—	
<i>The Forests of India and their products</i> ...	118
<i>'Kamila' dye in Ganjam</i> ...	122
<i>Indian Gutta Percha</i> ...	122
<i>The new Professor of Forestry at Edinburgh</i> ...	123
<i>Change of Editorship of the Revue des Eaux et</i> <i>Forêts</i> ...	123
<i>The Forest Department List</i> ...	123
<i>Effects of parasites on trees</i> ...	124
VII.—TIMBER AND PRODUCE TRADE.—	
<i>Selling rates in the N.-W. Provinces for fourth</i> <i>Quarter of 1891.</i> ...	25
<i>Churchill and Sim's Wood Circular of February</i> <i>3rd, 1892</i> ...	26
VIII.—EXTRACTS FROM OFFICIAL GAZETTES	

THE
INDIAN FORESTER.

Vol. XVIII.]

March, 1892.

[No. 3.

A Tour through Kamraj—Kashmir.

(Continued from last issue.)

No. 3

In the Mawar Valley is Yihama another very pretty village situated on the main stream of the Mawar River. At the back of the village is a fine hill covered with what, at a distance, looks like a good compact forest of pure deodar but on going through it, I found that owing to lopping, when the trees were young, it is nothing but a forest of trees with gnarled knotty trunks a few feet high, surmounted by a crown formed of half a dozen branches which have taken the place of the leading shoot and this sort of thing is to be found in almost every deodar forest situated near villages, good trees only being met with high up on the hill side. From Yihama we had a beautiful march to Rajpura; first we mounted up through a lovely deodar and kail forest which contained the best trees yet seen; the path was so steep that the horses had to be led to the summit and here we paused to take breath and enjoy the beautiful air and scenery; on the other side, the path was much steeper and it was with difficulty the horses were got down at all. Here the first thicket of deodars was passed through, a very poor example, as the trees were mostly badly grown and stunted; but it afforded further evidence of the impossibility of giving deodar for hop poles; in this thicket the only trees that would have served the purpose were some five or six that dominated the rest and should on no account be cut, yet under former circumstances these would have been the very ones taken out. In addition to the usual destructive practices, it was here observed that fine long poles of deodar were used for fencing the fields and this in a country which abounds in Parrotia! Our camp was pitched at Rajpura, the Jaghir of one of the petty Rajas with which this country abounds; he has chosen a lovely spot for

his home, a small plain on the bank of a pretty little stream. The houses are of the log hut style but large and spacious and the whole village is surrounded by magnificent walnut trees, while above them is a small range on which is a ziarat in the midst of some grand deodars which, of course, are sacred: would that there were more ziarats in the forests! From the village, a lovely road runs up the valley, the hills coming steeply down well covered with trees, altogether a most beautiful place and one well worth a visit. Leaving Rajpura with regret, our march was to Shalura on the Kamil River: first a climb over a bare hill too steep to ride, then a descent through a kail forest to the village of Sarmarg where we halted during a passing shower, then on through a lovely country of alternate forest and field to Waisa village, where another halt was made for breakfast. Here I amused myself with counting the number of trees used in a house just put up and found it to be 220 young deodars; this house was built in two storeys with a staircase in the centre and a broad verandah in front, in which the cattle are kept, the whole a fine substantial building about 16 feet high to the eaves and one that could be made suitable for a forest rest-house by putting an inner wall of planks and doors and windows. After this a little more forest and then a descent into the broad plain known as Ram Mahal, another Jaghir of Raja Amar Sing. This is one vast rice field and extends for some miles to the foot of the range dividing Kashmir from the Kishanganga Valley. We camped at Shalura, not at all a nice place, very swampy and malarious and only notable for the presence of an old fort of importance in the days when the Paharis, as the Kishanganga people are called, used to raid over into this fertile valley, but raiding is now out of fashion and the fort has collapsed. The swampy lands contain great quantities of *Lastrea thelypteris*, Desv. some of the plants of large size. Hearing that a friend and his sister were camped at the top of the range, we decided on joining them there for a day or two prior to a diversion on my part into the Kishanganga Valley, where I wished to see some logging work that was being carried on. From Shalura the road is a very pretty way up the valley past Kalapura and other villages to a Goojur hamlet known as Farikand. This Valley contains some very fair forests mostly kail but one or two of deodar. Much damage has been done, and in one place about 100 young silver fir trees were seen lying in a nala; on enquiry it was found that these had been felled by goatherds some three or four years ago to provide fodder for their flocks as they passed along! Near this were some eight or ten trees of larger size just felled for building purposes, no attempt being made to utilize those already felled; is it to be wondered at that foresters are a brutal set! From Farikand the path became too steep for horses and these had to be left behind. After a stiff mile up hill the ridge was reached and then there came a couple of miles up and down to Sarpat, a bare spot at about 10,000 feet

elevation, just below the crest of the main range, on the other side of which lies the Kishanganga Valley. We joined our friends here and experienced some of the excitement of camping at a high level, for a violent storm came on making it bitterly cold while it lasted. Our baggage did not come at all, so we had to borrow a few things for the night and rough it. I found the value of a "postheen" ulster and stockings, as they formed my bedding for the night. Next day was spent in exploring along the range for ferns, and many interesting ones were found. *Asplenium viride*, Hudson; *Athyrium thelypteroides*, Michx; half a dozen varieties of *Lastrea Filix mas*; acres of *Osmunda Claytoniana*, L, lately fruited in many cases; *Polypodium lineare*, Thunb.; *Phegopteris vulgaris*, Mett.; *Polystichum Prescottianum*, Wall and var. *Bakeriana*, Clarke; a var. of *Athyrium Filix Femina* perhaps *dentigera*, Wall; *Polystichum Lonchitis*, L, very fine; *Athyrium fimbriatum* var. *sphaeropteroides*, Clarke; *Asplenium septentrionale*, L; *Cryptogramme crispa*, R. Br. very common and of large size; an *Adiantum* not unlike *Wattii* but perhaps only a high level form of *A. venustum*, Don. The view from Sarpat is a very grand one, to the N. W. lie the mountains of Kaghán and in the N. E. is the giant Nanda Parbat 26,629 feet high, the fifth highest peak in the world, a great massive mountain of strangely rounded form, and to the E. of this a lower peak very pointed in outline. Here we saw the first lot of Kashmir ponies roaming about at their own sweet will; their owners bring them up early in the year from the villages below and never trouble themselves about them till the autumn, when they are caught and taken back to the villages, they do not appear to be branded or marked in any way, so that it speaks well for the honesty of the people that the practice should continue. The ponies are very small, none over 13 hands: very few of them are of any value as they are slight in make and not at all well shaped. The ladies were occupied in trying experiments in bread-making and as their efforts were successful, an excellent loaf being produced, it may be useful to travellers to describe the process. Mix some refined (Delhi for choice) flour with wheat *Ata*, a teaspoonful of Yeatman's baking powder, a little salt and sugar kneaded together with sour milk (*déhi*); *lastly* a small spoonful of carbonate of soda, bake in a quick oven. If no oven is available, a large *degchi* does just as well. The kneading should be well done, and if properly baked, the result is a very good example of camp bread made without yeast. Small rolls lend themselves particularly well to this process.

Next day, taking merely a flying camp with me, I left Sarpat for the Kishanganga Valley, my destination this day was the village of Kéran, situated on the river; the distance turned out much greater than was anticipated, for the march occupied eight full hours, exclusive of a rest midway and Kéran was not reached till long after dark. After a steep descent from Sarpat to

the valley below, the path ran nearly level for a couple of miles, crossing and recrossing a pretty little stream. On some rocks I found an *Athyrium* (?) to which I cannot put a name, also a tiny, plant of *Asplenium Ruta-muraria* L, which appears to be very rare in Kashmir. Further on, some fine plants of *Adiantum pedatum*, L, and *Asplenium fontanum*, Bernh. At about midway down there is some really good deodar forest, of course best on the N. slopes, but on the S. side where the deodar occurs in narrow lines down the sheltered sides of the ridges, there are also some very fine trees, of which one was measured 18' feet in girth, a fine sound tree, straight and of great height. The country here is very different to the Kashmir side, the slopes very steep and much precipitous ground, very much the same as Chamba. Logs could not be extracted from these forests as the nala contains very little water, but sleepers could be taken out at an extra rate, in large numbers. Here it was refreshing to find very little damage done to the trees, a little hacking for torches but no barking. The last two miles had to be done by torchlight as it had become very dark, and as every one was pretty tired, the coolies almost giving in, there was nothing for it but patience and a determination not to go ahead of the baggage. By torchlight, I gathered some beautiful specimens of *Diplazium japonicum*, Thunb, growing in a water course under a dripping rock. At Kenan which is some 50 miles above the junction with the Jhelum, the Kishanganga is a fine broad stream free from obstructions, excellently well adapted for floating both logs and sleepers. It is spanned by a wooden bridge and there is a small fort on each side. Leaving Kenan early next morning I tramped down the right bank to Salkalla. This is a very different climate to Kamraj, the valley is a narrow one and intensely hot after 9 a.m. and as the path lay almost all the way over bare slopes there was little shade. The *Quercus Ilex* grows here (vern : "chur") and the people are no longer Kashmiris, they call themselves *Paharis* and do not understand the Kashmiri language. *Pistacia integerrima*, *Fraxinus Moorcroftiana*, *Cedrela serrata* and the olive occur here, though not in the Kashmir forests. All the names of trees are different, *Pinus excelsa* instead of *kairi* becoming *biar* and so on. The wild grape grows luxuriantly and as it was just ripe, I was able to ascertain that the fruit has a very pleasant flavour and is most acceptable on a hot and thirsty day. Next morning I started on my return journey to Sarpat. I had to retrace my steps up the river to where there was a jhula to be crossed at Palri village. The jhula was an ancient one and in a very bad state of repair, and we had to wait about an hour while sundry ropes of *Parrotia* twigs were being bound round it to strengthen it. Much amusement was afforded by the passage over it of three men who had never seen such a thing before, much less crossed one; my khit, a native of Gujrat, started off with a bumptious air as if it was nothing, and had to be stopped short

and told to take off his chaplis first, still he went over very boldly and was evidently not a bit nervous. The other two, residents of Jammu, could not face it alone, so the old lambardar actually went over backwards in front of them to give them courage. My nerves are good enough for most things but I must confess that this would be beyond me. After this a tramp along the river bank over boulders till we reached the Raota nala up which the path ran by which we were to cross the range back into Kashmir. This is a beautiful ravine with some charming bits of rock and stream and huge trees, and many an inviting place for a rest amid the undergrowth and ferns; the words of an old song kept recurring to me as I trudged along through the lovely scene :—

“ Oh ! how sweet in forest glade,
When the noonday sun is shining,
Underneath the pine trees shade,
On a bank of moss reclining ”

and I blessed my stars that my lot was cast in such a pleasant place, instead of sweltering under a Punka as before. This nala contains some excellent deodar forests; at one place there is a nice little patch on abandoned cultivation, the trees are very straight and well grown and not too close together. No fellings have ever taken place here as it is too far from the river, but there is nothing to prevent it being worked for sleepers and there are a good number of mature trees. One dead giant was measured 20 feet in girth, as straight as an arrow, and perhaps 150 feet high. Nothing good in the fern line was found here, except what I provisionally call *Athyrium McDonelli*, Bedd. I camped at the foot of the steep ascent to the Raota Pass (a pass is known as *Mâle* here) at the last hamlet up the valley; a very steep country, there hardly being level space enough to pitch a small eight foot tent. This was very nearly burned down in an experiment made on the stump of a blue pine close to it, this had been hollowed out for torchwood and was dripping with resin, a match was applied and the flame that shot up was a sight to see and but that water was handy, I should have looked very foolish. Next morning a very early start was made, as the march was a very stiff one; for an hour and a half we toiled up a very steep and slippery path through the forest, till we reached an open *Marg* where I had breakfast and enjoyed the beautiful air, made bracing by the presence of the hard snow above us. After a rest and one smoke out of the old briar, I went on again over the snow for another hour till the top was gained. This is a very good place for ferns and some grand specimens of *Lastrea Brunoniana*, Wall. and *L. barbiger*, H. K were gathered. The whole hill side was covered with beautiful flowers, but the names are beyond me, I am sorry to say; there is also a small, white-flowered rhododendron here. I also found several plants of *Kuth* at about 10,000 feet, in

the forest : and higher up, on the bare hill side, the wild rhubarb, but with such short stalks as not to be worth picking. Even from this short glimpse of the Kishanganga Valley, it is evident that there is still much good forest left, though probably at a distance of a couple of miles or more from the river. It is said that all the forests close to the river have been cut out, and this may be the case, as fellings have been going on for many years past ; if so, then the supply of timber in log from the river must be a small one in the future, but there is little doubt that many sleepers can still be brought out, though perhaps not at present when prices are so poor. The general direction of the Kishanganga is from East to West and the right bank has generally a S. E. aspect, consequently most of the forests are confined to the left bank. The configuration is mostly from steep to precipitous so that demarcation will be a difficult and lengthy business : but it is the first thing to be done in this State, for there are rumours of thousands of Goojurs migrating from the Poonch State to settle in Kashmir as cultivators, and it should be mentioned that Goojurs here are not a nomad race as in other parts, but settle down and cultivate just as other villagers do. It therefore behoves the Forest Department to save what they can and that as soon as possible, though how this is to be done with the present establishment is a very puzzling question.

From the Raota Pass I had a long tramp up and down hill along the bare grassy range for about seven miles back to camp, stopping every now and then to examine likely looking rocks for ferns but beyond a fair specimen of *Pellaea Stelleri*, Gmel.; found nothing new and in this respect Kashmir appears to be far behind the Chamba Valley. The interrupted tour in the Kamraj District was now resumed, our next march being down the same valley past Farikand to Dardpur, this was a most enjoyable camping place. The village stands in a valley between very low hills on which can be found many nice grassy places under blue pine trees ; we chose one very fairly level, with two or three trees near, and after clearing off the *Indigofera* bushes had space enough for three or four small tents. This place was much warmer than Sarpat, being about 6,000 feet elevation, but the air was quite balmy with a strong scent from the kail trees near. Here a two days halt was made to get through a great accumulation of vernacular papers, in fact these are so numerous, that I can hardly keep pace with the day's post, so that, as yet, I have found little time for anything beyond the mere administration.

J. C. Mc.D.

(To be continued.)

The Classification of Ants.

The Ants are divided into:—

1. Formicidæ which have only one knot in the pedicle and are not armed with a sting.



2. Poneridæ.—which have only one knot in the pedicle but have a constriction between the 1st and 2nd segments of the abdomen and are armed with a sting.

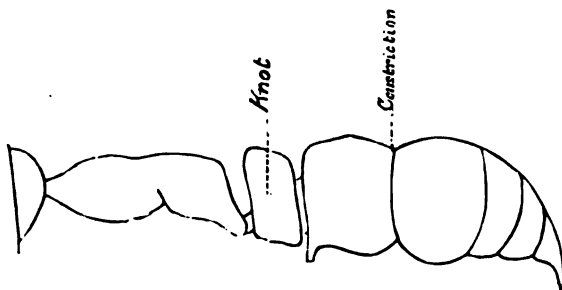

3. Dorylidæ.—which answer to the “irregular verbs” of our childhood—some approach the Poneridæ and some the Myrmicidæ.

4. Myrmicidæ,—which have two knots in the pedicle and are armed with a sting.



The illustrations above represent in each case a *Worker*, i. e. what is commonly known as “an ant.”

The *Queen* resembles the *Worker* but she has wings and even when these have fallen off the articulations may easily be seen with a magnifying glass.

The *Male* usually resembles in no way the *Queen* or the *Worker*. He is winged and does not shed his wings. He has seven segments in the abdomen while the *Queen* and the *Worker* have only six.

The *Soldier* is a form of the *Worker* from which he differs

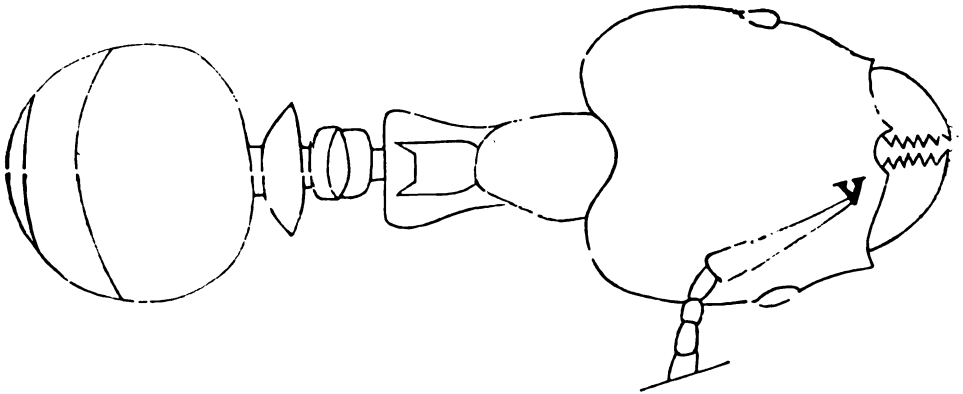

by his greater size and monstrously developed Head. The illustration represents a *Soldier* of the genus of which the illustration under *Myrmicidæ* is the *Worker*.

The two illustrations are drawn to the same scale.

In collecting, every endeavour should be made to obtain a large number of specimens of each species and care should be taken not to mix together specimens of different species. Single specimens are sometimes however valuable—*Queen* and *Male* are ordinarily of small value without their corresponding *Worker*; but when the *Worker* is also taken, their presence quadruples the value of the collection. The *Soldier* form is not always present. But those genera in which there is a *Soldier* form, can only be satisfactorily identified from that form.

In almost all genera there are gradations of size in the *Worker* form which should, if possible, be represented.

To pack the specimens, take a glass tube full of spirits, drop in all the specimens of one species, also a small paper with serial number *in pencil* folded up, a wad of cotton wool. Recommence with a fresh lot of specimens, a ticket and a wad of wool, and so continue until the tube is full, when cork tightly. In the illustration below, the packing is necessarily shown *too loose*. The wads should be pressed firmly down, not so hard as to press the specimens out of shape but hard enough to prevent shaking.

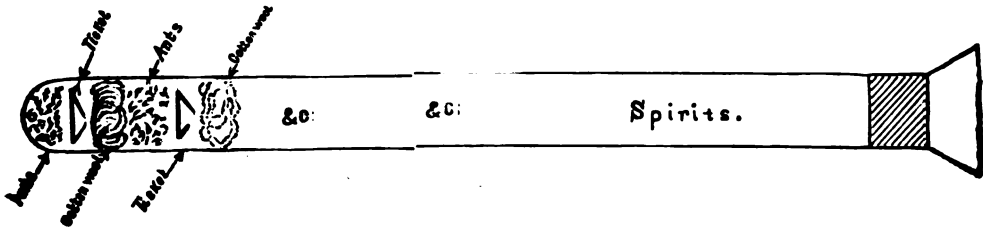

A Memo: to accompany the collection, giving locality, date, manner of nesting, notes of habits, &c., &c., adds very largely to the value of the collection. The tickets with serial numbers render the keeping of this memo quite simple.

The filled tubes can be sent by post in pieces of bamboo or otherwise. Undersigned will be happy to pay carriage of collections so despatched.

Address,

R. C. WROUGHTON,

Divisional Forest Officer.

Poona.

Thana Forests and their Working Plans.

A large amount of curiosity has been lately shewn by some Foresters who study Administration Reports, regarding the nature of the Working Plans which have been adopted for the forests of the Thana District of the Bombay Presidency, and a wish has been expressed that some Bombay Forester should give some account of these Working Plans. I venture to put the following notes together with a view to fulfilling this desire.

My experience of Indian Forests is limited to the Bombay Presidency, but from what I have read and heard I think there can be no doubt that the Forests of Thana differ in a great many important respects as regards their conditions, as much from forests of any other part of India, as they do from those in any other part of Bombay. The natural consequence is that they require a somewhat different mode of treatment. The area of Thana is is about 3,940 square miles and its population, according to the last census, over 1,000,000 people or an average of 250 per square mile; it may consequently be considered a thickly populated district. The forest area is about 1,350 square miles, scattered over the face of the country and not cramped into a few large natural blocks. The forest Settlements that have been made hitherto, have, as far as possible, endeavoured to make the forest areas as compact as may be, and in some cases the formation of large blocks has been successfully carried out. Nevertheless, the

majority of the forest land is in large irregular patches, separated from each other by cultivated land, village and waste lands. The country is extremely hilly, and is bounded by the sea on one side and by the Sayhadri Ghauts, 2,000 feet high, with peaks reaching to 4,000 feet; on the other side the hills are rugged and precipitous and their slopes contain a very large percentage of the Forest area. Until the passing of the Forest Act in 1878, the lands in charge of the Forest Department amounted to 135 square miles only, but in 1879 about 1,400 square miles of waste lands—really natural forest,—were notified under section 34 of the Act as Protected forest for inquiry and settlement. The settlement of this vast area has been in progress ever since 1880, but as yet only about half of it has been completed. In the settlements that have been made, some of the lands taken up have been thrown out, and of the rest by far the greater part has been made Reserved Forest. Until serious forest conservancy was introduced, the people of the District had been allowed a considerable amount of freedom in regard to the use of the natural forest; no restriction was placed upon their cutting, except with respect to teak trees—which have always been recognized as Government property whether in forest, waste or cultivated lands. The rapid emergence of Thana—due to its proximity to Bombay, and later, to the construction of two important lines of Railway through its length—from a state which must have much resembled the Great Forest described by Stanley in "Darkest Africa," to its present state of advanced civilization has been very rapid. Elphinstone described the Konkan (Thana and Colaba) prior 1818, as a "thinly inhabited forest, from which character it has even now but partially emerged." But the population, with its ensuing extended cultivation of the land, and advance of trade, appears to have increased by leaps and bounds; and a few years later, in 1837, there were evident signs of exhaustion of the forests, due to irregular exploitation, which attracted the attention of Government, and the necessity was recognized of protecting the forests of the country if any were to remain. Measures of conservancy were early taken, but it was not until 1862 that strict conservancy was introduced. Although the area actually in forest was at this time small, the term Government Forest included in those days all the tree covered waste land, of which parts were used from time to time by the people for sporadic cultivation, pasture and 'rab' (ash manure) supply. From a date before 1862, in fact almost from the date of the appointment of Dr. Gibson as Conservator in 1847—but with greater force since 1862—all attempts at forest conservancy have been made in the teeth of opposition from the people and to the accompaniment of their outcries against any restrictions being placed upon their requirements in timber, firewood and 'tohal' (branch wood) for rab (ash manure). The strict conservancy introduced in 1862 forced up the prices and demand for timber and firewood, and the people, wherever they

had the power, were quick to avail themselves of the offers of wood merchants and to sell to them the tree growth on their own land. The cries for timber, firewood and tahal from the Government forests then naturally became more accentuated. It is unnecessary here to go over the whole history of events and concessions made. It is sufficient to relate that the people, besides being allowed to take what they required from waste lands, not included in forest, were also allowed to cut for tahal all but certain reserved trees in Protected forests, as well as grass and brushwood in any kind of forest. But as the Protected Forests became changed by Forest Settlement into Reserved Forests, difficulties again began to be experienced with the people, for no free cutting of trees could be allowed in Reserved Forest, and the privileges granted in Protected Forest ended with their conversion into Reserved.

The people, if left to themselves, would very probably have settled down soon to the new conditions and have found other means of providing for their wants. Dead wood could still be obtained from the forests, and in addition to fostering tree growth for tahal on their own lands they might have arrived at using grass and cowdung to burn on their fields, as is actually done in many parts of the District. But the cultivators of Thana are, in many respects, like the cultivators of Ireland, little educated and endowed with feelings that are easily worked upon. The rich classes in the District, finding living and cost of cultivation becoming dearer, worked up the ryots to protest against the new regulation; emissaries were sent through the country who succeeded but too well in raising the people and keeping them agitated; mass meetings of the people, deputations and conferences succeeded each other, and without dwelling further on the subject, it may at once be stated that finally the Forest Commission of 1888 was appointed, whose labours culminated in the production of four volumes of report which showed fully the whole history of the case and contained recommendations for amelioration which, to some extent, have been carried into effect. This report was followed by further discussions, reports, &c, but the final position arrived at has been the decree of Government that any system of working the forests of Thana must be co-ordinate with a system by which cultivators may be able to get what they require in firewood and tahal in as convenient a manner as possible from the Government fellings. Here then is really the kernel of that nut so hard to crack, the reason of the system of Working Plans pursued in Thana. All Foresters must recognise what a tie the foregoing order must be to the hands of the Forest Officers concerned in the working of the Thana forests. The arrangement borne in mind in formulating the Working Plans has been that the inhabitants of every village which has contributed land to forest, may be able to obtain from the annual coupes, material free

for tahal and firewood at a convenient distance from their villages, which distance has been fixed at not more than four miles. What system but that of numerous Working Circles can comply with such a condition? It must not however be thought to follow that such a system of Working Circles would be introduced by the Forest Officers, if it could not be proved that it could yet be worked with success. Forest Officers in the Bombay Presidency, are not in the habit of sitting quiet under orders which they conceive to be dangerous of execution without injury to the forests for whose welfare they owe their *raison d'être*. The present Working Plan system was only adopted after careful consideration by experienced officers and the conviction arrived at, that, whilst meeting the requirements of the people, as prescribed, it would also benefit the forests. So far as can be judged at present, it is fulfilling the objects aimed at and is fitted for the production of the timber required. The defence of the system will be entered upon presently.

Now, as regards this Working Plan, to which the foregoing observations are an introduction. Summed up in a few words, it consists of a system of working by area. Attention is paid to routine in so far that the amount of material worked out every year is calculated from the registers of passes after exploitation. But in order that the same volume may be exploited every year, dependence is placed upon the rule of averages. The 1,350 square miles (864,000 acres) are divided into 310 Blocks and one coupe in each Block is worked annually without reference to the quality of the forest in any Block, on choosing the coupe for the year that naturally follows the pre-arranged sequence of exploitation. As, naturally then, it may be expected that the coupes will compensate each other and an average of routine be maintained. In forming the Working Plan, the forests of each range were taken separately and separated into as many Blocks as was found advisable, care being taken to have the Blocks as compact as possible, whilst keeping in view, as a measure of size, an imaginary Standard Block of 2,000 to 3,000 acres of exploitable forest. Many Blocks, for divers reasons, exceed these dimensions, containing perhaps an area of forest too high situated to be at present exploitable, as climatic forest, &c. Topographical maps on the scale of 4 inches to 1 mile were utilized for the representation of each Block, and on these the sequence of coupes is shown. The system of exploitation is that of Coppice under Standard with a rotation of 40 years; each annual coupe would therefore consist of 1-40th of the area of the Block. When, however, the Block contains forest which, for various reasons may not be worked, such area of forest is, of course, deducted before the size of the annual coupe is fixed. Natural features of configuration of the soil are utilized to the utmost extent in making the boundaries of the coupe and this also prevents the size of the annual coupe being necessarily absolutely fixed.

Next, as regards the delineation of the coupe upon the ground. This is done by a surveyor armed with a Topographical map of the proposed coupe, from which he fixes the boundaries. Firmly built square stone cairns are erected at the corners of the coupe and at any angles in the boundary lines where necessary; then at every chains' length between the cairns a stone is firmly bedded in the ground and painted red. Also trees along the lines of boundary are marked. Finally, sketch maps of each coupe showing the cairns, with the number of intermediate stones to each, are prepared and handed over to the Range Forest Officer and Round Guard, in addition to the Divisional Forest Officer. The work is not so laborious as may be thought from the above description, and it is absolutely necessary, in dealing with men so keen and unscrupulous as are the wood merchants of Thana. The coupe boundaries must be determined in such a manner that they cannot be shifted without detection. In the first year of the introduction of the system in South Thana, before the delineation of the coupes was made quite as thorough as it is now, two cases came to light where Government was defrauded by the shifting of the boundaries of the coupes outwards, laying down more stones, &c., and so enlarging the coupes.

The reservation of standards is done with great care, the number varying according to the nature of the ground, from 15 per acre on the flat to 30 or more per acre on steep slopes. The coupes are sold standing to contractors by tenders taken in August, and the cutting may be commenced on 1st September. All cutting must be finished by 31st March, and all material removed from the coupe by 30th April, and from the Dépôt, outside the coupe, by 31st May following the sale. The contractors are bound down by agreements containing stringent terms and containing plenty of power given to the Divisional Forest Officer to enforce the same. The system is found to work excellently in practice; out of 161 coupes offered for sale in N. Thana this year 140 were sold, 5 are being worked departmentally and 17 only, situated chiefly in out-lying parts of the District, remain unsold. The outturn of the coupes sold to contractors amounts to Rs. 2,50,000, an average of Rs. 35 per acre for the area exploited, which is a fair result in consideration of the facts (i) that few of the teak trees exceed two feet in diameter and most are considerably less; (ii) that the demand for jungle wood timber is small and most of the trees are converted into firewood and charcoal.

Reference has been made to material which the people of the forest villages may obtain free from the coupes. The people who may exercise the privilege are the inhabitants of the villages which have contributed forests to the Blocks and each village exercises the privilege only in the annual coupe of the Block to which it has contributed forest. The material which they are allowed to take free, and which material they may begin to

take from the date the contractor starts exploitation on the coupe without hindrance from him, is

- (a.) All grass and brushwood in the coupe ;
- (b.) All branchwood of 6 feet or less in circumference, leaves, &c.

An experiment which I have made shows that this amounts to a grant of about 4 tons of material per acre, weighed three days after cutting in an average coupe. Besides this, they may take for tahal, from any part of the open portion of the Block, grass and 13 kinds of shrubs. The closed portion of the Block consists only of the exploited coupes, which may be closed absolutely for 10 years after exploitation.

The points to be put forward in defence of the plan of working the Forests of Thana are as follows :—

I. The necessity already dwelt upon of co-ordination with the wants of the people of the District.

II. The fact that, up to the year, 1887 no system had been followed in the working of the Thana Forests. It had been the habit to cut almost nothing but teak and there was pressing necessity for the introduction of some systematised method of working. The system which could the most readily be introduced with the certainty of arresting deterioration of the forests and of working up to the annual increment was chosen. The system was, in fact, a tentative measure, and is still on trial.

III. More than half the forests to be worked were only Protected Forest under Section 34 I. F. A. It was unwise to introduce a more elaborate Working Plan when the eventual area of the forests was yet undetermined.

IV. A large area of the forests to be dealt with had for years been subjected to destructive privileges over junglewood trees (*i. e.* trees other than teak and blackwood) to such an extent that now many forests contain nothing but teak with scrub-undergrowth of stunted junglewood species. It was necessary to convert such forests into proper mixed forest and the plan selected was the readiest to effect this object.

V. Teak, though the most considerable and the most important product of the Thana Forests, does not there attain large dimensions. The reason for this is hard to say. In the last century the teak forests of Thana were undoubtedly fine, for they supplied the Bombay Dockyard, and Hové in his travels in Thana in 1786, mentions the presence of large teak trees. But the export of large teak from Thana in the last century was enormous ; all the big trees must have been cut down for it is now rare that one meets teak trees of large dimensions there, neither does the timber equal in quality that of Burmah or Kanara. The teak trees in

Thana which have taken the place of the previous fine crop now after attaining at the most a diameter of 2 feet go, 'sur le retour,' become hollow at the base and couronné. Perhaps forest fires, which as a regular occurrence are of recent origin, are the cause, and as these become more checked large teak may be again producible.

VI. The size of timber calculated to be obtained by the 40 year rotation is such as is in demand in the parts of the country in which the produce of the Thana forests is absorbed, viz., pillars, posts and rafters in the round and roughly squared as used in building the ordinary native houses both in cities and villages. For large and fine timber used in more important works, the teak of the Thana Forests will never be able to compete with that of the Burmese and Kanarese forests. If, in the course of a few years, it becomes clear that the anticipations of the rate of growth of the teak have been too sanguine, it will not be difficult to re-arrange in some measure the Working Plan and increase the rotation to sixty years.

VII. Finally the production of large timber is not altogether lost sight of, the number of reserves left in each coupe is considerable, and these are always selected from the healthiest trees, likely to live the term of the rotation.

The great danger to the success of the Working Plans is the possibility of fires in the early years of closure. The exploited coupes are carefully fire-traced along their boundaries every year and the occurrence of a fire in a coupe under exploitation is heavily visited upon the contractor of that coupe.

The coppice is found to grow readily and strong, from stocks cut flush with the ground. Whether thinnings will be necessary and if so when they should be made is a matter that is still under observation. The subordinate forest staff is neither sufficiently numerous nor sufficiently educated to be trusted with this work. The oldest exploited coupes yet are only of 5 years standing, in them the teak coppice holds its own and seedlings also are coming up.

The foregoing is, as well as I can render it, a full account of the whole system of working pursued in the Thana forests: and I will conclude by remarking that when Mr. Ribbentrop and Mr. Hill were in Bombay last year, the opportunity was taken by Mr. Shuttleworth, the Conservator of Forests, Northern Circle, of showing them some of the Thana Blocks, when coupes under exploitation and coupes already exploited were inspected and the whole system followed was fully explained to them on the ground.

G. P. MILLETT.

THANA DISTRICT,
15th January, 1892.

The advantage of preliminary practical work in the training of Forest Officers.

In our January Number, Mr. W. R. Fisher gives us his views about practical and theoretical training for the students at Coopers Hill and his paper gives me the impression that what he advocates is, theory to begin with, then practice, that practice being chiefly visits to forests and works on tour with little or no personal work. As an old pupil of M. Clément de Grandpré and as one of those who spent a very profitable eight months in the forests of Alsace under his supervision, I should like to say a few words about those points of his Article in which I differ in opinion from Mr. Fisher. We went to Haguenuau in March, 1869, and were there till we joined at Nancy in October of the same year. Our work was almost entirely practical: we had some few lectures on chemistry and physics in Haguenuau, but the real work was outdoor. We had to accompany the Inspecteur or Sons-Inspecteur; and with them and the Gardes-Généraux, we were expected to assist in all the operations which were carried out. Day after day we were out doing 'balivage' or 'estimation' or 'récolement' or we were told off with compass and chain to cut off coupes and so on. The result of this, I speak for myself, was, that I think, got to understand what Forestry meant, to know something of the trees and their sylviculture; to understand a forest as a whole and not as a collection of individuals; and, in short, to feel myself more or less a Forester, before I went to Nancy to begin the drudgery of lectures and 'études' in the stuffy rooms in the Rue Girardet. I can honestly say that I believe I got more real good from that practical teaching at Haguenuau than I did from the stereotyped lectures of Professor Bagnéris. I do not know what it was in Mr. Fisher's time, but in mine, there was none of the 'comparison of systems' he talks about: to the best of my recollection, we were told little or nothing about working plans except that they were a very abstruse study which we should only be allowed to hear about in our second Nancy year, after we had fully got to understand the sylviculture course. We were of course told and shewn how one forest was treated in 'Futaie,' another in 'Taillis,' but that was about all, and I am sure that so far from M. Clément having given us a bias on favour of any special system, he was most careful to teach us nothing but natural facts and how to observe them and how to carry out simple operations. I believe I am right in saying and I think the others of my year would bear me out, that when we began our theory at Nancy, we began it with some 'pull' over our French comrades. How could it be otherwise? They were youths fresh from the Lycées; most of them hardly knew one tree from another, much less had ever thought of there being anything very much to be learnt in connection with them; and so, even with our comparative

disadvantage in language, we could understand the lectures at once and picture fairly well to ourselves as we heard them, the forest as it is in nature, which was, I think, something deal more than they could.

In my opinion, there is no better introduction to a career which consists, or ought to consist, of practical work for life, than to begin by practice. Mr. Fisher compares Forestry with Medicine and Engineering! Now, in old days, I believe, nearly every doctor began his studies as an apprentice, he compounded drugs and he assisted his master in his surgical operations from, I think, what we should now consider a very early age, and it was only after he had obtained a certificate of a certain practical competence, that he was allowed to go to medical lectures to qualify for his degree. At the present day, I believe I am right in saying, almost all of our most eminent Engineers began their studies 'on works' and 'on works' they were probably for five times the number of years that a Coopers Hill student spends at College, before they began to rise. We have most of us read the lives of Stephenson, of the Brunels and others; we see in the papers accounts of the rise in the world of Eminent Engineers of great name, and I full sure that no sensible Coopers Hill Engineer, though he may have found a more 'Royal' road to his career, will think himself better than they because he has escaped much of the preliminary drudgery that they underwent. Here too, in India, much of the best work of the Department has been done by men who never heard a theoretical lecture or entered a German forest! I would draw attention to the leading article in the *Gardener's Chronicle* of January 2nd, where, in reply to a request from the Vice-Chairman of the Middlesex County Council for his opinion on the question of giving theoretical instruction in horticulture, it is reported that Mr. W. T. Thiselton Dyer, the Director of Kew, said "I know of no royal or theoretical road to the 'acquisition of a competent or even useful knowledge of the 'gardener's art except by beginning at the bottom and going 'through every operation from the most elementary to the most 'difficult and refined. Our men must gain their capacity for 'themselves by working under the skilled direction of able 'foremen." As with Horticulture, so it is with Forestry; if an officer is wanted who can supervise Forest works to the fullest advantage, he must know personally and practically how to do those works himself, so as to be able to shew his subordinates how to set to work; and in my opinion it will be a bad day for the Department when we replace those who are practical men and can themselves do forest operations practically, by officers who prefer (under our unfortunate Indian bureaucratic system) to write official letters and order others to do the work, very possibly with failure as a result. It is often easy enough to say what should be done, but it is much better to know also how to do it.

I can agree entirely with Mr. Fisher that for preliminary practical experience it is not necessary to go to Germany: it is most useful for students to go there *after* their course, to see in the field the applications of the more difficult and scientific portions of their training; but I should like to see all our students, whether of Coopers Hill or of Dehra Dún, made to do themselves at the outset a good practical course of the elementary work which is much the same in all countries and may be done in England or Scotland or India as well as in France or Germany. That practical work should be real practical work: they should learn to thin forests, to make nurseries, to plant trees, to prune and tend, by actual personal experience, and here I may remark that this is what we are trying to have done at Dehra, so far as our limited time allows, and is what the Board of Control of March, 1891, strongly and rightly insisted on, when it required that first year's students should begin their forestry by learning artificial reproduction both theoretically and practically, and should not proceed to silviculture even, till they were able to do it in the camping season with the object lessons in front of them.

The tendency, which I should regret much to see, of what, I take to be Mr. Fisher's ideas, that is, beginning with the theory and reducing the practice to tours only, be might to turn out a number of young men crammed with theoretical notions of Forestry, and able to describe the various systems as they had seen them in Germany and France in their tours; and after all incapable of doing, or supervising the doing, of simple practical operations such as the replanting of a denuded hill side or the thinning of an over-crowded compartment; and looking grumblingly upon the simple often monotonous every-day work of most of our Forest Divisions as mere drudgery. Let us have, by all means, at Coopers Hill, as I know we have, the best theoretical instruction possible, but let us not forget that, after all, theories are only made to be put in practice and that if an officer is unable to do the simple operations which constitute the elements of Forestry, he is not much better off than a soldier would be who could talk learnedly on the trajectories of projectiles but could not hit a target at a hundred yards.

Mr. Fisher has given us a splendid list of possible training grounds which students of Coopers Hill are to visit in their third year. But is there not a danger in shewing them too much? May it not be better, as I certainly think it is, that they should see a little of the best, but see that well, assimilate it thoroughly, and learn how to copy it themselves in practice, than that they should come out to India, having seen everything there is to be seen, and yet, after a year or two, having in their minds merely a kaleidoscopic sort of mixture of methods and systems and a general hazy notion that such and such were good things to do. Speaking as one who has more to do with forest education than

anyone in India, I can only say that I should prefer the Coopers Hill man who was well grounded in practical work and could do the operations with his own hands when need arose for shewing how they should be done, to the one who could quote his text books by the yard but yet could not set his Ranger right if he found him doing his planting work wrong and could not take the axe or the billhook himself and explain practically the mistakes in a simple operation. So too, at Dehra Dún, we should prefer the student who could give an intelligible account of what he saw on tour, and did in the field, and could carry out elementary operations himself at once and so be sure that he could rightly direct his staff, to the one who had learnt the Elements of Sylviculture by heart, but who would only come to grief when he lost the catch word or was asked for a practical illustration. I have heard Conservators and Divisional Officers complain that the students turned out of Dehra Dún were full of theory, but unable to set to work when told to do a simple operation in practice. There is no doubt but that the complaint was sometimes well founded, but we are now doing our best to remove it, and if we are successful, it will only be because we are all doing what we can to abolish cram, and to teach our students to develop their powers of observation and carry out in the field in practice the ideas they are given in their theoretical lectures.

In conclusion, I have to apologize for a paper so full of strong opinions; my readers will I hope forgive them in remembering that those opinions are not entirely my own only, but that after all, at Dehra, we have to carry out the system of teaching laid down by a Board which consists of the Chief Officers of the Department and that their present orders are the *Encouragement of practical training*.

J. S. GAMBLE.

II. CORRESPONDENCE.

The Coopers Hill Prospectus.

DEAR MR. EDITOR,

In Volume XVII of the *Indian Forester* of 1891, I have just read the short article on "The present Prospectus of the Forest Service Branch at Coopers Hill" that appears in it. Leaving the first half of that article (which deals with the change of subjects for the competitive examination) out of the question at the present moment, I pass on to a paragraph in the Prospectus to which attention is very properly drawn. The paragraph I refer to is No. 16 of the new Prospectus which runs as follows:—

“The pay of an Assistant Conservator of Forests will commence with the date of arrival in India. Probationers who acquit themselves creditably during their course at Coopers Hill College will begin on a salary of Rs. 350 a month; those who fall short of the required standard, though they may have obtained the College diploma in Forestry, will begin on Rs. 250 a month; and this difference of salary will continue until the first Departmental Examination is passed in India. It will rest with the President of the College, in consultation with the Principal Professor of Forestry to decide which probationers, if any, have failed to qualify for the higher initial salary.”

Now, I wish to draw the attention of those interested in the future probationers at Coopers Hill, to rule what this rule actually means. Before doing so it is necessary to give a few explanations. *Firstly*, when a probationer enters Coopers Hill, a certain professor of the College is appointed to act as his “*Tutor*.” This “*Tutor*” really acts to the student as a sort of schoolmaster, he has power to “gate” him for not attending chapels, lectures, etc; he has power to stop all his leave from the College; and he has every opportunity of thoroughly knowing the character, and general bearing of the student he has under his charge. So far, so good; but now, what I want to point out is the following.

This same professor is not only the student's *tutor* but also his *Lecturer and Examiner* in many cases, a state of things which, in my humble opinion ought not to exist; and I imagine that there are many other Forest Officers, if not all, who will agree with me on this point.

All I ask is, that the Examiners should be men in no way associated with the college, so that it should not be in the power of any student's “*Tutor*,” from any personal motives on his part, to say such a thing as I once heard a professor say to a fellow student of mine, namely “Look here, young man, if you go on treating me this way, I shan't qualify you at the end of the term.” This incident actually happened in my hearing. However, far be it from me to impute to any of the professors at Coopers Hill College any deliberate unfairness, but I maintain that it is impossible for the professors who know all their students so well, to mark their papers with the same degree of equity as an examiner who is quite unknown to them.

Personally, it matters very little to me now what rules they have at Coopers Hill. But I take a great interest in those that come after me, and so I have written the above to you, Mr. Editor, in the hope that in due time the proper influence will be brought to bear on the authorities to change this state of things, which, as I have already remarked, in my humble opinion, is unfair.

FOREST OFFICER.

III. OFFICIAL PAPERS & INTELLIGENCE.

Rules to regulate appointments and promotions in the Provincial Forest Service.

I.—THE FOREST SERVICE.

The Forest Service of India is composed as follows:—

- (a) The Imperial Service.
- (b) The Provincial Service.
- (c) The Subordinate Service.

(a) THE IMPERIAL SERVICE.

The Imperial Forest Service is recruited solely by officers directly appointed by the Secretary of State for India.

(b) THE PROVINCIAL SERVICE.

The Provincial Forest Service consists of—

- (a) Foresters who have obtained the Dehra Dún Forest School Certificate, Lower Standard.
- (b) Forest Rangers.
- (c) Extra-Assistant Conservators.
- (d) Extra-Deputy Conservators.

(c) THE SUBORDINATE SERVICE.

The Subordinate Forest Service, consisting of Foresters, Forest Guards, and other subordinate officials, is recruited from men appointed by Conservators or by Divisional Forest Officers under the sanction of section 40 of the Forest Code, and who do not pass through the Dehra Dún Forest School.

II.—THE PROVINCIAL FOREST SERVICE.

The Provincial Forest Service can in future only be entered through the Dehra Dún Forest School.

III.—ADMISSION RULES.

The rules for admission to the Forest School are as follows:—

1. There are two courses—one in English (the upper class), and a second in Hindustani (the lower class).

The former prepares students for the certificate in forestry by the higher standard; the latter for the certificate in forestry by the lower standard.

2. Application for admission to the School may be made in the first instance either to the Director, or to Conservators of Forests direct, or through Divisional Forest Officers. Candidates for admission must not be less than 18 nor more than 25 years of age: exceptions to this rule will require the previous sanction of

the Government of India. Each candidate must furnish a certificate of sound health, and of good vision and hearing, from the Civil Surgeon of the station nearest to his place of residence.

3. It is the duty of the Director or the Conservator who receives the application to satisfy himself that the candidate is of good moral character and active habits; also that he possesses fair powers of observation, sense of locality, and such other qualifications as are necessary for an officer of the Forest Department.

4. Candidates* who are accepted under Rules 2 and 3 for the English Course must, before admission to the School, pass an Entrance Examination in the following subjects, viz:—

English—composition and conversation.

Arithmetic.

Algebra—up to and including quadratic equations.

Elements of Euclid.

Mensuration—lengths, areas, and volumes.

5. This examination will be held before an officer of the School or before such officers of the Educational Department as the Local Governments may appoint for that purpose. The examination will be held either at the Forest School, or at such other convenient educational centres as the Local Governments may direct.

6. Conservators of Forests, including the Forest Officers of Coorg and Ajmere, are required to report to Local Governments by the 1st of January in each year the number of approved applicants, and submit proposals regarding the place or places at which the examination should be held.

The officers appointed by the Local Government to conduct the examinations should despatch to the Director on the 15th January in each year an application for the number of sets of examination papers to be sent to them. The examination papers will be forwarded from the Director's office, under sealed covers, not later than the 15th of the following month.

The examinations will be held simultaneously throughout India on three successive days about the 1st March, the precise dates being fixed by the Director at the time that the examination papers are sent out. Examinations held on dates other than those thus fixed by him will be treated as invalid. The candidates' written answers will, after countersignature (with date) by the officer presiding at the examination, be returned in a sealed cover to the Director of the school. The Director will subsequently inform Conservators of the result of the examination.

7. The Local Government may, under such rules as it may lay down, require that there be selected from the list of passed

* Except those of Burmese, Shan, or Karen extraction, who, as a temporary measure during the years 1891 and 1892, will be admitted into the School after passing such Entrance Examination as a Conservator of Forests in Burma may deem sufficient.

applicants such number as it may deem desirable to admit into the Provincial Forest Department at the end of the School course. Applicants so selected will have a preferential claim to be appointed to the Department.

8. Local Governments may grant to special candidates while pursuing their studies in the upper class at the School who, are not already in receipt of any Government pay, an allowance not exceeding Rs. 50 a month under the conditions prescribed in Rule 13. Students will, on passing out of the School by the higher standard be eligible for appointment as Rangers under section 34 of the Forest Code, and can then be promoted to the class of Extra-Assistant Conservators under the special provisions of Rule 2 (b.) in VI *infra*.

9. Local Governments may depute to the Forest School, in order to attend the English course, officers who have served in the Subordinate Service for a period of not less than one full working season, provided that they have passed the examination prescribed in Rules 4 and 5. The age of all such officers shall be less than 25 years: an exception to this rule will require the previous sanction of the Government of India.

10. Local Governments may also depute Rangers to the School in order to qualify themselves for further promotion (a) in the class of Rangers, or (b) to that of Extra-Assistant Conservators. Such officials may be above 25 years of age, and need pass no qualifying examination, but will require to hold a certificate from the Conservator of Forests, under whom they are serving, that they possess sufficient general education and ability to enable them to profit by the English Course of instruction at the School.

11. Candidates for the Hindustani Course may be admitted as prescribed in the case of the English Course in Rules 2 and 3; but, in lieu of passing the Entrance Examination laid down in Rule 4, they must furnish a certificate of having passed the Middle Class Examination in the North-Western Provinces and Oudh, or an equivalent standard in another Province, as well as a certificate that they possess a competent knowledge of Urdu or Hindi.

12. Local Governments may depute to the Forest School, in order to attend the Hindustani Course, officers who have served in the Subordinate Service for a period of not less than one full working season, provided that they have qualified as prescribed in the preceding rule for the admission of students of that class. The age of all such officers shall be less than 25 years: an exception to this rule will require the previous sanction of the Government of India.

13. Persons who may enter the Subordinate Forest Service with a view to being deputed for instruction to the Forest School at Dehra, as well as those who may be granted a Government stipend under Rule 8, shall be bound down by a formally executed

Agreement—the sureties for the fulfilment of which should be men of some position and means—to continue in the Government Forest Service for a period of not less than five years after passing out of the Forest School, and on such rates of pay as may be in accordance with the existing organization of the Department. A breach of this condition, otherwise than with the consent of the Government of India, will render the offender and his sureties liable for the refund to Government of the entire cost of his education at the Forest School. The Agreement and Security Bond shall be in the appended forms (Appendix I),* and must be executed before the student is admitted to the School. The Agreement will be signed by the student and, if he is a minor, by his father or guardian also; the Bond by the student and two sureties.

14. The obtaining of either of the certificates at the School will not, otherwise than as provided under Rule 7, be held to constitute a claim to Government service, although, when vacancies in the service occur, due consideration may be given to the fact that certificates have been obtained.

15. Students must supply their own note-books and stationery. Books from the book depôt will be supplied to them on cash payment only. Breakages and damages of School property must be paid for at once. As security for the due fulfilment of this condition, each student, not already in the service of Government, is required on entering the School to deposit a sum of Rs. 50 with the Director, the balance of which (if any) will be returned to him when he leaves. Students must, during their stay at the School, defray their own expenses, including the cost of travelling. Travelling allowances are granted to students already in the service of Government.

16. Candidates from Native States must apply, through the Darbar, either to the Director or to a Conservator of Forests. The conditions for their admission are similar to those laid down for other students. Native States sending students to the School shall, before the beginning of each term, deposit with the Director a sum equivalent to the estimated cost of the students' living at School for that term as stated in Rule 5 under IV, *infra*, as well as the security deposit of Rs. 50 provided for in the preceding Rule. Remittances for students from Native States must be made by drafts payable to the students and forwarded to them through the Director.

17. Previous to receiving into the School any person who is not already in Government service, or in receipt of a stipend from Government or from a Native State, the Director shall satisfy himself that the candidate or his friends are able and willing to provide him with funds up to the amounts and at the times laid down in the estimate appended (Appendix II). A student who fails in this respect to satisfy the Director shall not be allowed to remain at the School.

* Not printed.—H. Ed.

IV.—GENERAL RULES.

1. Candidates admitted to the School must join at Dehra Dún on the 25th June next after the date of their passing the Entrance Examination.

2. The courses of training extend over 21 months, the time being spent as follows:—

1st year.

1st July—31st October	At Dehra.
1st November—22nd December	In camp.
23rd December—5th January	Vacation.
6th January—31st May	In camp.
June	Vacation.

2nd year.

1st July—31st October	At Dehra.
1st November—22nd December	In camp.
23rd December—5th January	Vacation.
6th January—14th March	In camp.
15th March—31st March	Final examinations.

3. At the close of the course of instruction, successful students will receive a Certificate in Forestry (Higher or Lower Standard) with or without honours.

4. Students who have completed their course leave the School at the end of March; but any student who has failed to obtain his certificate may, at the discretion of the Director and in the case of students already in the service of, or in receipt of a stipend from Government, with the sanction of the Local Government, or in the case of students from Native States, of the Darbar, be retained to complete another full year's course of instruction. But during the course of instruction no examination for the final certificates will be held. Students who have failed to obtain the certificate by the Higher Standard by ten per cent, or less of the necessary marks, may, at the discretion of the Director, be granted a Certificate in Forestry by the Lower Standard. Conservators of Forests—the students selected or deputed by whom are about to under-go their final examinations—are required to inform the Director, before the end of February in each year, as to the place to which each student on leaving the School is required to go, and as to the amount of the advance, if any, which may be given to enable him to reach it.

5. The average monthly cost of living at the School is calculated to be as follows, *viz* :—

For students living in the Native style	...	Rs. 22 to Rs. 28.
For students living in the European style	...	Rs. 35.

The above figures include the cost of food, ordinary clothes, uniform, rent, books, and instruments. The expenses of travelling

and camping during the entire course of 21 months are calculated to come to something like an additional Rs. 130 for the former class, and about Rs. 210 for the latter class. The ordinary travelling allowances admissible to students already in the service of Government will cover these expenses. (For details see Appendix II.)

6. All such students must, unless otherwise permitted by special order of the Director, live in the School quarters, if rooms therein are available. The rent charged is Rs 2 per mensem for *each* student. Private students may be given quarters, when available, on the same terms.

7. During the course of instruction, the Director will furnish Conservators, or *Darbars* of Native States, with monthly reports on the character, application and progress of the students sent by them to the School.

8. Students are liable to the following punishments :—

- (1) Reprimand by the Teacher in class
- (2) Reprimand by the Director or the Deputy-Director at any time.
- (3) Reprimand before a Meeting, convened by the Director, of not less than three School Officers, one of whom must be either the Director or the Deputy-Director. The proceedings of the Meeting will be reported to the Conservator or the Native State deputing the student; and, if the Meeting so decides, a note of them will be made on his final Certificate.
- (4) The Director, acting with the consensus of the Meeting referred to under (3), has power to inflict, in addition, a fine to the extent of one-third of the salary or allowances of the student for a period not exceeding three months.
- (5) The Director, acting with the consensus of a full Meeting of the School Officers presided over by himself, has power to dismiss any student for misconduct; and a student thus dismissed cannot be re-admitted to the School.

The Director may remand any student who, in his opinion, is not sufficiently promising.

V.—APPOINTMENTS TO THE CLASS OF FOREST RANGERS.

Appointments to the class of Forest Rangers may be given*—

- (1) To passed students of the Dehra Dún Forest School—
 - (a) who have obtained the School Certificate in Forestry (Higher Standard) with or without honours;
 - (b) who have obtained the School Certificate in Forestry (Lower Standard) *with honours*, and who have

* The Chief Commissioner of Burma is authorized, as a temporary measure, to appoint as Rangers in Burma, in the absence of duly qualified candidates, persons who do not fulfil any of these conditions.

afterwards rendered not less than *two years'* satisfactory service as Foresters ;

- (c) who have obtained the School Certificate in Forestry (Lower Standard) *without honours*, and who have afterwards rendered not less than *five years'* satisfactory service as Foresters.

All such appointments to fill existing vacancies may be made under the orders of the Conservator of Forests.

Candidates who are not natives of the province in which the appointment is to be made, or of a province in which one of the principal languages is the same, must furnish a certificate of having passed an examination by the lower standard in one of the principal languages of the province ; or, in Burma, of having passed by the Elementary Standard in Burmese.

(2) Where there are no officers of the 1st class qualified for appointment, but not otherwise—

- (a) to subordinates who have earned such promotion by long, faithful, and meritorious service ;
- (b) to Native Non-Commissioned Officers of Her Majesty's Army who have entered the Forest Department under the orders contained in Circular No. 25-F., dated 13th November, 1880.

Such appointments, to fill existing vacancies, may only be made under the orders of the Local Government.

VI.—APPOINTMENT TO THE CLASS OF EXTRA-ASSISTANT CONSERVATORS.

Appointments to the class of Extra-Assistant Conservators (on salaries varying from Rs. 200 to Rs. 350) may be given—

(1) To Forest Rangers—

- (a) who have obtained at the Dehra Dún Forest School the Certificate in Forestry (Higher Standard) *with honours*, and who have afterwards rendered not less than *two years'* satisfactory service as Rangers in executive charge ; or
- (b) who have obtained this certificate *without honours*, and have afterwards rendered not less than *five years'* satisfactory service as Rangers in executive charge ; or (in exceptional cases only)
- (c) who were members of the Forest Department on the 1st December, 1881, and who, though they have not obtained the Certificate in Forestry (Higher Standard), have done specially good and faithful service, including a term of not less than *five years'* as Forest Rangers, and who have received a good general education and possess a sufficient knowledge of English.

(2) Where there are no Rangers in the province qualified for promotion under the above rules, but not otherwise—

- (a) to candidates who, prior to the 1st July, 1891, had been nominated by a Local Government under the rules embodied in section 36 of the Forest Department Code (3rd edition);
- (b) to Rangers who, otherwise qualified, have not served the prescribed time.

In granting such appointments, students who obtain certificates *with honours* should be preferred to those who obtain certificates *without honours*.

Candidates nominated prior to the 1st July, 1891 will continue to draw the allowances granted to them under section 39 of the Forest Department Code (3rd edition).

VII.—APPOINTMENTS TO THE CLASS OF EXTRA-DEPUTY CONSERVATORS.

Appointments to the class of Extra-Deputy Conservators (on salaries varying from Rs. 450 to Rs. 600) will be made by the promotion of officers of the Lower Controlling Staff who hold the Higher Standard Certificate in Forestry of the Dehra Dún Forest School, and who have done good service of not less than five years as Extra-Assistant Conservators in either of the two upper grades (Rs. 350 and Rs. 300) of the latter class.

VIII.—PROVINCIAL FOREST SERVICE.

The Provincial Forest Service will be allotted to the same six Provincial lists on which the Imperial Branch of the Upper Controlling Staff is borne, and the members of the Provincial Service will be shown on those lists according to seniority in service. Promotions will be made on each Provincial List as a whole, and not in respect of local Circles.

IX.—PROMOTIONS IN THE PROVINCIAL FOREST SERVICE.

Promotions in the Provincial Forest Service will be regulated as follows :—

Forests to the class of Rangers if they have qualified under V (1).	}	By the Conservator.
Foresters to the class of Rangers if they are considered qualified under V (2).		
Rangers from grade to grade.	}	By the Local Government.
Rangers to the class of Extra-Assistant Conservators.		
Extra-Assistant Conservators from grade to grade.		
Extra-Assistant Conservators to the class of Extra-Deputy Conservators.		
Extra-Deputy Conservators from grade to grade.		

Notes.—We print this *in extenso* for the benefit of our subscribers at home who may not have had the opportunity of seeing it officially.

HON. ED.

IV. REVIEWS.

Forest Conservancy in Victoria.

We have read with considerable interest the first report of Mr. G. S. Perrin, appointed some three years ago Conservator of Forests for the Colony of Victoria. It carries us up to the end of June, 1890, and though the period of which it treats is now rather far away, nevertheless, the information it gives will be new to some of our readers. Mr. Perrin has a Forest Staff, called variously, inspectors, superintendents, foresters, foremen, nurserymen, besides labourers, and after mentioning their services, he goes on to speak of the training of Foresters. He admits at the outset that foresters trained in the small plantations of the old country would be useless in Victoria and he advocates selecting men from his own colony and sending them through a course of agriculture and forestry in the agricultural colleges of Longerenong and Dookie, to be followed by a six months course of nursery work in connection with the state nurseries at Macedon and elsewhere. There is no doubt this is the right way to begin, and this sensible suggestion of Mr. Perrin's, we trust, will be acted upon by the Victorian Government.

The different kinds of work going on in the forests appear to be as follows;—

1. Thinning the indigenous timber.
2. Saw mill areas.
3. Planting operations.
4. Supply of mining timber.
5. Fire protection.
6. Control of grazing.

We propose briefly to notice these various heads. Thinning the indigenous timber has been going on for two years, and about 4,000 acres have been gone over with the most gratifying results.

‘ The young seedling redgum of Gunbower for years past have simply been ruined by the dense growth, and if left in that state would have in time degenerated into a whipstick scrub. Now all this will be changed: acre after acre will be thinned, letting air and light into the young forest, the effect of which will be that the young trees will soon recover, and grow into saw-mill timber in the course of 25 years or thereabouts.

‘ As soon as the necessary trained hands become available, the forests round Sandhurst, the magnificent ironbark ranges, will be taken in hand and dealt with a similar manner to the other forests. The other great forest centres will then be undertaken in the order of their importance.

'The value of this work cannot be overestimated. We have in this colony magnificent young forests, which only require energetic supervision and intelligent 'thinning' to make forests of the utmost value to the community, and to supply all the wants of the consumer for all time.

'In certain of the chief mining centres, planting is not required—the indigenous forest is growing up fast enough for re-forestation purposes. Our native timber trees would be hard to beat in the markets of the world for general utility; hence, protection and thinning are the wants of our forests in the great mining centres, and these will be the care of the Department."

In the dry arid plains and in sandy wastes it is intended to grow hundreds of thousands of sugar gums and blue gums in bamboo tubes. We gather that the bamboos will have to be raised for the purpose, and the system of planting out in bamboo tubes is fully described on pages 11 and 12 of the report, with a photo-lithograph of the apparatus required.

The system known as "saw-mill areas" is best described in the words of the report :—

"Under the present regulations, a saw-miller may take out area rights at £ 1 per 100 acres (up to a maximum of 1,000 acres) per month. It is thus possible for a saw-miller to take up 1,000 acres—rent £10 monthly—put on 100 or more men, and cut off all the timber in a couple of months at a cost of only £20. The saw-miller may also take out another area in another forest, and proceed in the same manner.

'The remedy for this is to license the fallers in connexion with areas, and limit the number of areas any firm or saw-miller may take up. The area system is not wasteful. It necessarily keeps out the splitter, who is the true and primary cause of waste, the saw-miller only taking the timber necessary for his trade requirements. During the year the minimum diameter at which timber can be cut has been raised from 18 inches to 24, and as the increase has been received by the saw-millers with approval, it bears out the contention that only large-sized trees are required by the saw-miller.

'I am decidedly of opinion that the special area system is a good one, and until the 'royalty' system is adopted, I know of no better. It is not wasteful, because it does not pay a regular saw-miller to cut down trees unless he can use up the same at the mill."

The Conservator is evidently endeavouring to suppress the destruction of timber, but, as he says "it is well nigh impossible to expect men to watch the whole colony and keep an efficient look out upon the thousands of persons whose direct interest it is to obtain timber without licence." We should say so! 24 men for an area of 87,884 square miles. But we are not told what the area of the State forests amounts to, and we should not be surprised to learn that there is no one in the colony of

Victoria or anywhere else who can give us this information. Have the forests been demarcated and is there a map of them? That is a question we should like to see answered in a future report. The foundation stone of all rational forestry in any country in the world is to secure a sufficient area of State forest, to demarcate it and then to survey it. When this has been done you can continue with the superstructure.

The most important nursery is situated at Macedon, where about 700,000 young plants were raised during 1889 and 1890. But other nurseries in other localities have also been established and it is expected that in a year or two the output from each nursery will reach half a million. Mr. Perrin is, however, fully alive to the fact that protection from fire and from grazing, combined with judicious thinnings, will do far more for the re-foresting of Victorian forests, than thousands of pounds spent upon tree planting.

The supply of mining timber in the neighbourhood of Sandhurst, Ballarat and other important centres is strictly supervised. The blue gum appears to yield the best results, and this and other suitable kinds will be planted out in bamboo tubes, to supplement the yield from the natural forests. This is necessary as most of the forests round the chief mining centres have been over-worked and require rest. In the words of the report—

“The miner is now awaking to the fact that one source of his wealth—the timber—by which he is enabled to unearth the yellow metal, is failing him. Timber he must have, or else give up the quest for gold. He asks the Government to step in and save him from the folly of timber destruction. To do this properly he must be prepared for sacrifices; he must submit to see the forest lands properly fenced and placed under strict supervision; he must give up his old ideas as to his rights to timber; he must recognize no rights save those of the Crown; he must be content to receive the timber from the forest according to the bearing capacity of that forest; he must submit to being heavily fined if he should transgress the forest laws, he must assist the forest officers in their work by moral and active support. If he does all this, there is a certainty of a regular supply of timber being available for his use.”

The remarks of the Conservator on fire protection will have special interest for us in India. After alluding to the inflammability of the pine forests in America he says—

“The pine forests of Europe and America have not the wonderful recuperative or resisting power of our Eucalyptus forests. The fact of our trees being shedders of bark instead of leaves, marks the eucalypt as being eminently adapted for hot countries where fires rage periodically during the summer months. The eucalypt is to a large extent a fire-resisting tree, some species more so than others. The well-known stringy barks

' (*E. obliqua*, *E. macrorhyncha*, *E. capitellata*) are familiar instances known to all bushmen.

' There, are doubtless, few old residents in the colony but have seen forests of this valuable timber tree alight from base to topmost branch, with a fiery furnace around their stems sufficient to roast a herd of cattle, not a leaf, nothing but a blackened, bare butt towering aloft to the sky, funereal and desolate looking. Yet, after a heavy rainfall, behold, a few weeks afterwards, the blackened boles and bare branches put forth young shoots and leaves and in a few months nearly all trace of fire is obliterated and thus summer after summer, forest after forest is burnt, destroying saplings by millions, but the old sturdy pioneers of the forest still live on, and year after year continue to shed fresh seed upon the burnt up ground, and then the saplings reappear as thick as ever under the genial influence of the winter rains."

The causes of fires in Victoria are very much what they are in India.

" The cause of bush fires in nine cases out of ten is through the culpable negligence of persons whose business or pleasure takes them into the forest. The splitter drops his matches carelessly about, or leaves a box on a stump. The bullock driver throws a lighted match into the scrub or by the road-side. The swagman leaves his fire alight at the camp. The sportsman uses paper gun wadding, and starts a fire at almost every shot.

' The Fire Act of Victoria is a dead letter, and police, selectors, tourists, sleeper hewers, and contractors generally, look upon the notices with indifference."

To remedy this state of things the Conservator makes certain definite proposals which we trust he will be able to carry out—extra establishment, stopping of 'commonage,' restricting the entrance of the public, and indiscriminate camping, amending the Fire Act, fencing in of State forests, and formation of fire lines. A beginning has already been made, extra men were put on, and about 21 miles of fire lines were burnt in the various forests.

The receipts from grazing fees are not credited to the Forest Department but to 'General Territorial Revenue.' It would seem that the various forests are leased for low sums to local residents; as an example we may give the redgum forest of the Murray Flats, 65,000 acres of which is leased for £200 a year, whereas in the sister colony of South Australia, where the leases run for 14 years, the rent varies from 3d. to 2s. 6d. an acre. The Conservator justly remarks:—

" Both these state forests (Murray Flats and Gunbower) should be regarded as national estates from which large grazing revenue should be received and this would undoubtedly be the case, if the reserves were blocked off and let by tender on a secure lease for a term of fourteen years.

‘ There is no doubt but that if this were done, a revenue
‘ of between two and three thousand pounds sterling annually
‘ would come into the Treasury to the credit of the Forest
‘ Department.

‘ The loss of revenue is by no means the worst part of the
‘ affair. Commonage means the taking out of the hands of the
‘ Forest Department the management of the grazing, and imme-
‘ diately a division of interest arises, as the power of dealing
‘ with the matter is relegated to a number of persons who natur-
‘ ally care more about the fattening of their cattle than the well-
‘ being of the Forests.

‘ The Forest Department should have complete control of the
‘ grazing in all state forests, and the sooner the fact is recognised
‘ the sooner will the forests become of use not only for grazing,
‘ but for the purpose for which they are, as a first consideration,
‘ intended.”

With regard to the revenue and expenditure, it may be stated that the former was £16,202 and the latter £5,218, leaving a balance of nearly £1,000 in favour of the Department. This surplus is sure to increase under intelligent supervision and we feel sure that the colony of Victoria has got the right man in the right place in her present Conservator. We only hope they will back him up in his suggested reforms, and support his moderate proposals.

A. S.

Descriptive List of the Timber trees of the Central Province of Ceylon.

By the courtesy of Mr. J. Alexander, Assistant Conservator of Forests, Kandy, we have been favoured with a copy of this list, prepared to illustrate the wood sections sent to the Colombo Exhibition in December, 1891. Had we had it before us when we reviewed the last Ceylon Forest Report for our February number, we might have identified many of the native names which we met with in that Report, with their scientific equivalents. *Diga-para* (*Wormia triquetra*) is said to be a useful wood for house-building, differing clearly in these respects from its relations the *Dillennias* of India which have pretty woods with a fine silver-grain but which split too easily, and decay too soon to be of much use. Several species of Sapu (*Michelia*) are said to be useful cabinet woods and are probably used as *M. nilagirica* on the Nilgiris and *M. excelsa* at Darjeeling. ‘Kina’ is the Ceylon name for the Poon spar, the (*Calophyllum tomentosum*) said to be very valuable. ‘Na’ is the *Mesua ferrea* and the name suggests the ‘Nahor’ or ‘Nagesar’ of Assam. ‘Mihiriya’

(*Gordonia zeylanica*) is said to be an excellent timber as is 'Ratatiya' (*Adinandra lasiopetala*). The Ceylon *Dipterocarpus* (*D. zeylanicus*) is 'Hora' and its near relations the *Doona* trees seem to be chiefly used for shingles. We note that, as in Darjeeling, the *Bombax malabaricus*, our 'Semul,' the Ceylon 'Katu-imbul' is largely cut for tea-chests. It is strange that in the Dún the planters will not look at it and prefer Mango. 'Halmille' is the *Berrya Ammonilla* or Trincomalee wood, common in the dry zone and largely used. 'Lunumidella' is the *Melia dubia* a tree which has puzzled many officers in various parts of India, with a pale toon-like, soft wood, used for tea-boxes. Our old friend the 'Bijasal' re-appears under the Ceylon name of 'Gammalu' with the curious remark that "Mr. E. M. Hay 'of Nawalapitya is the only planter in the Central Province that knows its value.'" 'Kumbuk' (*Terminalia tomentosa*) seems to be as much in demand in Ceylon as all over India; as is 'Kolon' (*Adina cordifolia*). 'Mi' is Ceylonese for our South Indian Mohwa (*Bassia longifolia*) the wood being used for carving work. We are surprised that among the Ebonies, the calamander wood (*Diospyros quersita*) does not appear.

Three exotic trees are mentioned; the *Acacia Melanoxydon* and *Eucalyptus Globulus* of Australia and the *Cryptomeria japonica* of Japan, which latter is said to grow freely in the planting districts and to give an excellent tea-box wood.

We will conclude, by expressing the selfish hope that the Ceylon Forest authorities will send to the Dehra Dún Museum specimens of those woods which do not occur in the Indian Forests.

Forest Work in Baluchistan in 1890-91.

The Baluchistan Forest Administration Report is always rather interesting, for it cannot have been an easy matter to start Forest Conservancy in such a country, *primâ facie*, about as unpromising as any could be. But progress is clearly being made, for there are now 78 square miles of Reserved Forests; a special forest Law has been brought into force and that law has met with but little opposition; forest fires are conspicuous for their absence; and some considerable success has been achieved in reproduction, both by natural means and artificially.

Mr. Elliot, the Deputy Conservator, who writes the Report, specially dwells at length on this latter subject. In regard to *natural* reproduction, he says that, that of 'shisham' and olive in the Sibi plains forests is good; that *Prunus eburnea* grows up well at Zarghun, near Quetta; that tamarisk is growing fast at Popalzai; but that the good effects of the winter rains were more than counterbalanced by the invasion of locusts. The chief work of *artificial* reproduction is the Shebo Plantation in Pishin

which now covers 1,076 acres, most of which was planted during the year. The trees planted seem to be poplar, willow, apricot, peach and almond, with some pistachio and tamarisk and the proportion of successes on the whole (83.3 per cent) seems good. We should be very pleased if Mr. Elliott or some one, would send us an account in detail of this interesting work, its situation, the methods of irrigation, planting etc.

Departmental working is confined apparently to the fuel supply of Quetta, while the sales to purchasers seem to have chiefly been in the Sibi Range. Dry juniper wood fetches 8 as. to 10 as. per maund in Quetta.

The rule that "the inhabitants are entitled to cut timber and 'firewood for household purposes without payment'" refers, we presume, to the open forests outside the Reserves. In any case it goes a long way to explain the deficit of Rs. 13,727.

The Report is reviewed by the Government of India in the Foreign Department, and they mention a Forest Conference as having taken place in December, 1891 in Quetta, so we will end by expressing the hope that we may soon be able to report to our readers the conclusions arrived at.

V.—SHIKAR.

Accident during the Garhwal Kheddas. The end of the rogue Elephant.

An account of the melancholy circumstances attending the death of the late Mrs. Anson, wife of Major Anson, the Agent for the Balrampur Estate, which took place during the recent Khedda operations in the Sonanadi valley in British Garhwal, may be of interest.

Sir Auckland Colvin, the Lieutenant-Governor and party arrived at Hathikund on the 30th January with a view of seeing something of the elephant catching operations. Major and Mrs. Anson did the honors of host and hostess on behalf of the Estate and all the camp arrangements were faultless.

At daybreak on the 1st February, the trackers were abroad, finding the exact position of the herd of elephants which had been for some days in the neighbourhood of Hathikund. At about 9 a. m. a "Sowar" galloped up to the bungalow where we were all assembled eagerly awaiting "Khabar," with the re-assuring news that the wild herd was feeding at a spot about three miles to the east of our camp, upon a small ridge separating two branches

of a *Sot* or hill stream. The plan of operations consists in placing men armed with guns and blank ammunition at intervals of about 30 yards along the spurs encircling the area containing the herd; when this has been done a few shots are fired at the head of the *Sot* as an alarm, upon which the wild elephants try and effect their escape but are met on all sides by blank fire and are finally obliged to run down the *Sot* itself. Here they are met at a conveniently narrow spot by the serried ranks of the Khedda elephants, previously drawn up in more or less crescent form. Upon this all is confusion, every mahout trying to bring his elephant alongside of a wild one and to get the rope noose over its head. This is, however, not very easy of accomplishment, and it often results in a long chase in which the wild elephant has a fair chance of escaping altogether. Supposing, however, that the mahout has been fortunate enough to get the noose over a wild elephant's head, his troubles are by no means over, for the animal finding itself caught by the neck struggles violently, often dragging its capturer through most awkward places, and occasionally coming to an untimely end by strangulation, owing to the rope getting caught among the trees in the forest.

In the present instance, however, the above campaign did not take place, on account of an unforeseen interruption which occurred as follows:—

The men with guns, some 200 altogether, having been posted out upon the ridges surrounding the herd, the Khedda elephants were got ready and started for the scene of action. It was a curious sight to see some 96 elephants moving along the forest road, single file, with their quaint-looking riders and Khedda gear, the whole procession extending over more than a quarter of a mile.

Every one was in high spirits, as a big catch was anticipated; and an elevated spot had been previously selected (near the point where the Khedda elephants were to be drawn up) to be occupied by the Lieutenant-Governor and party, which would command a fine view of the whole "tamasha."

The first elephant in the line was ridden by a tracker to show the way, the second by Major and Mrs. Anson, the third by Sir Auckland Colvin and Colonel Erskine, and the rest in no particular order. On approaching the base of the hills, a couple of shots were heard up in the valley in the direction of the herd, leading everyone to suppose that the wild elephants had in some way got alarmed and were trying to make their escape. Accordingly the line of elephants pushed forward as quickly as possible. The first portion of the line had just emerged from a narrow defile in the hills when a large rogue elephant charged down without any warning (which is, I believe, most exceptional in these animals) upon the line of elephants, from the right front, at a point where they were about to cross a

small nulla. The first elephant in the line avoided his charge, but the second was caught in the flank and overthrown with great force, the rogue then proceeding to gore it viciously with his tusks.

All this took place in a few moments, and before any one could come to their help the rogue had turned and fled, scared no doubt, at the general shouting and the appearance of so many elephants. It was unfortunate that no one in the neighbourhood of the accident was armed, and still more so that the line of elephants was not led by one of the famous Balrampur fighting tuskers, as in that case the accident would certainly not have occurred. As it was, however, Major Anson, who was not apparently much hurt, extricated his wife from her dangerous position, half crushed by the fallen elephant, and carried her to a place of safety. She had evidently received a very severe shock, but no one thought things were quite so bad as they afterwards turned out, so having carefully placed her on another elephant, Major Anson, accompanied by two of the party and a large tusker, returned with her to the camp. We stopped a short time, at Major Anson's request, to see if the herd would come down the valley, but they had in the meantime broken through the guns and made their escape, having been frightened no doubt, by the noise and shouting at the time the rogue charged.

We all returned, therefore, to the camp, there to learn the sad news that Mrs. Anson had died ten minutes before our arrival.

It appears that after they had left us to bring Mrs. Anson back to camp, they were again met and persistently followed this time out in the open, by the same rogue, and matters became so serious, that Major Anson was obliged to take his wife off the elephant again and climb up a bank with her to a place of safety. The tusker was of little or no use in the hands of a cowardly mahout who lost his nerve so completely on seeing the approaching rogue, that he refused to make his elephant face about and prevent its approach. Fortunately, however, it did not again charge, but turned off into a neighbouring forest ravine. The injured elephant was terribly gored and had to be shot soon after.

The whole party dispersed on the following day and Mrs. Anson's funeral took place at Roorkee on the 3rd February.

In this way, a meeting which should have proved most enjoyable to all, was brought to an abrupt and melancholy conclusion.

The vicious character of the rogue, the author of the mischief, has long been known in the neighbourhood, and this is not his first victim. He has frequently given chase to persons invading his domains, and to the truth of this I can personally vouch, having been chased myself for a considerable distance up a hill by this same animal some three weeks ago, when I inadvertently approached him too closely.

He has now, however, paid the penalty for all his misdeeds, as, after several days of ineffectual tracking, I had the good fortune to come across him this afternoon and having approached to within about twenty-five yards, dropped him with a 12 bore bullet propelled by 6 drams of powder. The bullet struck him in the middle of his forehead, but did not apparently quite reach his brain as he rose again to his feet in a few minutes, and I was obliged to fire four more shots into the side of his head before he sank, to rise no more.

He was a very large animal, height at shoulder 9 ft. 10 in.; and had fair-sized tusks, but was absolutely tail-less; a mark which has always sufficed to distinguish him from other elephants in the neighbourhood.

B. B. OSMASTON.

13th February, 1892.

VI. EXTRACTS AND NOTES.

The Forests of India and their products.

Very narrowly does India seem to have been saved from one of those wide-reaching famines which threaten its densely packed people every eight or ten years. As it is, South India, which is under different meteorological conditions from the rest of the peninsula, is suffering already many of the horrors of drought, in Chingleput, the district around Madras city, and in four other tracts. Famine to the peasantry means death to their cattle. The only means of supplying fodder to the latter in such dire extremity has been adopted by Government. The forest reserves have been opened to them. This is the first and most important result of our forest conservancy, though in ordinary times the people feel it a hardship that they should have to pay fees for grazing in the woods. Sad experience has proved that they cannot be trusted themselves to conserve the common woods and pastures. In 1850, for instance, when the land of Ajmere and Merwara, in Rajpootana, was settled for revenue, the wastes and hills were made over to the management of the villagers as part of the common land. What was the result? The soil was gradually denuded. The wood was sold, the grass which had grown under the partial shelter of the trees ceased. The scanty rain-fall became scantier. The sub-soil water supply and that in wells and streams became so uncertain that the magnificent tanks made by Colonel Dixon either dried up or were silted up by the sand washed down from the naked hills. The famine of 1874 came, and the cattle and people alike died out. Ever since, the preservation and extension of grazing woods have formed the duty of the Forest Department under careful legislation, and

hence it is now possible to alleviate the misery and the loss of the patient ryots of South India. Railways may bring into a stricken district food from more favoured parts, but cattle fodder cannot be distributed like rice and millet. Only the Forest Service, it is proved, can be trusted to produce it at such times.

The trees of a virgin Indian forest are the glory of nature. The writer has spent weeks in the red-wood forests of California, whose Sequoias in girth and height and beauty, are the wonder of the world, as they shut in the weird and spacious Yosemite valley. But even these came short of the vast Deodar plantations of the mighty Himalayas and of the Teak reserves of Central and Eastern India. Even in the comparatively small area of the Andaman Islands, the great penal colony of the East, there are glorious woods so dense that the sun never penetrates them, and so bound together by interlacing creepers as almost to defy the axe and the elephant. The stems of some of these climbing shrubs have been described to be as thick as a man's thigh, but as flexible as a rope. In other cases the rarest orchids cover the loftiest trees with luxuriant splendour—orchids, many of them varieties new to the botanist. Indian forest trees number more than 2,000 species entirely different from those which are common in Europe. In Great Britain, for instance, there are only about 40 species of indigenous trees.

The Deodar may for beauty be placed at the head of all. This noble cedar must not be judged of by the sickly exotic of our gardens, though that is beautiful enough. On the Himalayan slopes, at an elevation rising from 6,000 to 9,500 feet, it sometimes reaches a height above 200 feet. Of all timbers its wood is the most durable; we have seen beams of it in the rock-cut temple of Kharli, centuries old. With this tree may be associated the sandalwood of South India; it is a small evergreen with black berries dropping from the graceful-hanging branches, but its heartwood is that which gives it value. This strongly scented wood is exported to China for incense, and is used all over the East by Parsee and Hindu artisans for exquisite carving and mosaic work. Hardly less durable than the Deodar is the Teak (*Tectona grandis*.) If we except Java and Siam, India seems to have a monopoly of this valuable timber, which has taken the place of oak. It has been well said that what gold is to metals, teak is among woods. Not only is it durable, light, and not very hard, but it is easily polished and does not split or warp. Mahogany is hardly indigenous to India, having been brought from the West Indies by William Carey a century ago. But the now large and beautiful trees which he planted in the Mission Park at Serampore, and those which adorn the famous botanical gardens to the South of Calcutta, are reported by Sir D. Brandis to produce timber equal to that of the American tree. In Pegu it is now succeeding as a forest tree.

Along the 1,600 miles of the lower Himalayas, from the Punjab to Assam, two valuable trees almost constitute the forest belt—the Sal and the Sissoo. The timber of both is durable; the Sal is very hard, but the Sissoo is much used for furniture, with its fine polish. With the Sissoo is generally associated the Khair (*Acacia Catechu*), which is not only so durable as to make oil mills and rafters, but produces the valuable tanning material known as Catechin or Cutch. The catechin is produced by boiling down chips of the heartwood, the red fluid of which becomes hard and black. More important—however, to the manufactures of Europe is the India-rubber tree (*Ficus elastica*), which abounds in the evergreen forests of Assam. “The white milk which exudes from cuts made in the stem and roots is collected and dried, and forms the caoutchouc which is exported from Calcutta.” Unfortunately the tree is found chiefly in native territory beyond the frontier, where the reckless system of tapping is diminishing the supply. But the British forest officers are steadily extending plantations of this huge evergreen of the fig tribe, which rises to forty feet high. The export of rubber from India alone is sometimes of the annual value of £150,000. It is the people of India, however, who chiefly supply the forest revenue, in their payments for firewood, charcoal, grazing dues, bamboos, gums, fibres, and other minor produce. Take the Bamboo alone, that tall arborescent grass which, growing in dense clumps, reaches a height of more than 60 feet. To the native of India it supplies almost everything, even food in time of scarcity. It is the best material for building, the stout matting which it forms supplies walls, floors, and roofs; it is made into baskets; its hollow-jointed stems form oil and other vessels. In China, the fresh shoots of the Bamboo are made into excellent paper. Under proper appliances the Bamboo fibre seems destined to have an important influence on this manufacture. A very valuable export is the product of the Lac insect, which lives on forest trees, and is artificially propagated both in Bengal and the Central Provinces. It yields the shell-lac and lac-dye of commerce, so well known in sealing wax. The wild Gums of the Indian forest are now beginning to be valued as they deserve. Sir George Birdwood, a practical botanist, as well as our first authority on Indian art, has published a valuable treatise on the subject. The writer happened to be visiting the virgin forests of the great Andaman Islands, when the resident Scottish doctor there discovered the value of the yellow gum of the Gurjun, or wood-balsam tree, as a specific in the treatment of leprosy. The paper mulberry of Japan has been naturalised in Burma and Assam, for it yields the Tapa cloth of the South Sea Islands. There is still a wide field for the introduction of foreign trees and plants into India. The quinine-yielding *Cinchona* is a striking illustration of this.

The influence of forests upon climate may be observed on a great scale in India. So scientific an observer as Sir D. Brandis does not believe that the operations of forest conservancy will guard against the recurrence of seasons of excessive drought. But some important facts have been established. In the neighbourhood of dense forests the air near the ground is moister and the dew heavier than in the open country. A gauge placed above the crowns of the trees in the forests collects more rain than one outside at the same height. Well-stocked forests are a perfect shelter against scorching winds. There is no doubt as to their value in protecting the soil, and regulating the natural drainage, while they diminish floods and control torrents. The whole subject of the relation of forests to irrigation by wells, tanks, and rivers deserves careful study. The people of India themselves are awaking to the importance of this question, if only to raise firewood sufficient for our ever increasing consumption. As the old woodlands become exhausted through reckless cutting, prices rise, hence to supply the city of Madras, some of the land-owners on the coast over an extent of forty miles have been planting the Casuarina, which is indigenous on the coast of Burma, in the shifting belt of sand. The result is most profitable to the landholders and to the poorer natives, who receive a cheap supply, while large areas of waste land have thus been utilised.

The experienced officers who have done so much for forest conservancy in every province of India during the past generation have often been called upon to assist other countries and colonies. Thus New Zealand has enjoyed the services of Major Campbell Walker; Mauritius, those of Mr. R. Thompson; Ceylon, of Mr. F. d'A. Vincent; Cyprus, those of Mr. E. Dobbs; and Cape Colony, those of Mr. D. E. Hutchins. Indian Forest Conservancy is still in the infancy of its usefulness to the millions of our fellow subjects in the East, to botanical science, to commercial enterprise, and indirectly to the whole Empire. University Commissioners will fail in what is expected of them if they do not bring to a successful conclusion the movement which seeks to make Scotland, and Edinburgh, above all, the chief scientific and practical training school for forest students and officials at home and abroad. (*Scotsman.*)

The writer of this Article seems to have been a good deal misinformed. We believe the Madras Government have really thrown open very few closed Reserves to grazing, but have allowed the free cutting of grass instead. We should like, also, to know where the vast Deodar 'plantations' are that rival the giant trees of California. And the Madras Conservators would probably like to have even a few only of the giant Teak, in the forests of South India which have been so much ruined by careless timber-cutting by people who called it 'Conservancy.' The Casuarina growers, too, hardly find their enterprise most profitable, though it does pay; and the poorer natives will not cook their rice with Casuarina if they can get sticks of anything else.

Kamila dye in Ganjam.

Among the many rich natural products of Ganjam, probably the most esteemed in commerce is the red "Kamila" dye, the valuable product of the *Mallotus philippinensis*. This tree, with its lovely scarlet berries and vivid emerald green foliage, is a marked feature of forest scenery in Ganjam. The berries are coated with a beautiful red powder which constitutes the dye. This powder is collected by being brushed off into baskets made for the purpose, but the method of collection is reckless and wasteful in the extreme, the trees being often felled in order to reach the berries more easily. The industry is a monopoly of the hill Khonds, who, however, turn it to little advantage. They are ignorant of the great commercial value of the dye, and part with the powder to the low-country dealers settled amongst them for a few measures of rice or a yard or two of cloth. The industry is capable of great development, and a large fortune awaits the firm or individual with sufficient enterprise to enter into rivalry with the low-country native dealers settled amongst the Khonds, who at present enjoy a monopoly of the trade. It is notorious that these men are accumulating vast profits in respect of this dye, as they obtain the powder in barter from the Khonds for the most trifling equivalent, and send ship-loads of it from the district. The local native name for the dye is Sundragundi. The tree is cultivated largely by the Khonds in their forest villages.—(*Indian Agriculturist*.)

Indian Gutta-Percha.

An abundance of gutta-percha milk has been yielded during the past dry weather in the Wynaad by the *Panchotee tree* (*Dichopsis elliptica*, Dalz) and some planters have been asking for information on the subject and inquiring whether it could be made into a commercial article. The milk has been known for some years to afford what was called Indian gutta-percha or Pala-gum and has been used as an adulterant of Singapore gutta. General Cullen brought it to notice about 35 years ago, and Dr. Cleghorn published a memorandum on the subject at the time. It was reported upon by experts in London, who found that it was unfit for water-proofing purposes, as its solutions in coal tar and turpentine dry up to such a brittle consistence that the fabric is quite useless. It could be used as a birdlime or cement and keeps well under water. By boiling the milk of the panchotee tree a white mass separates, which can be kneaded by the fingers, but which becomes hard and brittle when cold. The brittle character of this substance I found in the true gutta and called crystalban or alban. Crystalban, according to Payen,

-occurs to the extent of from 14 to 19 per cent. in the best kinds of gutta-percha, but I have extracted as much as 69·2 per cent of crystalban from the secretion obtained from the Wynaad. The presence of a large quantity of crystals in this gum, of course, would interfere with its utility, but crystalban is easily removed by boiling alcohol, and the residue consists of a very good and pure gutta-percha. I cannot see why this process could not be used to purify the Indian gutta-percha and so obtain an article similar to the Malayan gum.—(*Report of the Madras Quinologist.*)

The New Professor of Forestry at Edinburgh.

Our readers will be interested to hear that the appointment of Professor of Forestry at the Edinburgh University lately vacated by Dr. Somerville, has been conferred upon Col. F. Bailey R. E. who was so long Director of the Forest School at Dehra Dun, and for some time acting Inspector-General of Forests in India. Colonel Bailey's interesting reports on Forest Works in various countries are well known to the readers of this journal and we wish him every success in his new appointment.

Change of Editorship of the *Révue des Eaux et Forêts.*

The number for January 10th, 1892, contains the announcement of the retirement from the Editorship, of M. Bouquet de la Grye, who has held it for the last 25 years. He is succeeded by M. Charles Broillard whom many of us know well personally and all as a former Nancy Professor. His last appointment was that of Conservator of Forests at Dijon, whence he retired a short while ago. The number of the *Révue* which announces his assumption of the Editorial position begins with an important paper from his pen on the exploitable age of coppice on limestone plateaux, which we hope some Indian Forest Officer will translate, for it cannot but be of interest to those who did their practical work in the Forêt de Haye.

The Forest Department List.

We have received the Madras and Bombay Lists for January, 1892, and the first idea they bring to us is that now more than a year has passed since we have had one for the Provinces under the Government of India. We hope the authorities will try and bring one out soon and not keep us waiting so long again.

A question, which a study of the Madras Lists brings to our mind: is, how are the new men from Coopers Hill to be placed on their arrival? Under new arrangements we know that they will shortly step at once into the 2nd grade of Assistant Conservators—but how about the supersession of the old 3rd grademen? Of these, there are no less than 9 in Madras, 8 of whom apparently are trained officers, and one of them of 3 years service has not yet passed the L. S. We notice, too, that one officer of excellent reputation for work has not yet passed the H. S. after more than 5 years' service. Can it be the case that the Language Tests in Madras are too difficult? Or is it that the paucity of officers has necessitated putting unpassed men into heavy posts where they have no time for study? The subject seems one to which the serious attention of the authorities might be directed and enquiry made as to the best way to remedy both this, and the possible grievance of the supersession of older men by young officers from home, owing to the change of Rules.

Effects of parasites on trees.

We reprint the following extract from the "Gardener's Chronicle" which seems to overturn our previous ideas on this subject.

If it be true that the host and the parasite are mutually advantageous to each other, how is it that trees are so often killed, to all appearance at any rate, by *Loranthus*? For instance, how will the cause of the death of so many attacked trees in the Bandy Shola Wattle Plantation in the Nilgiris now be otherwise accounted for?

MISTLETO.—"Up till quite recently it has been assumed that the growth of the Mistleto was necessarily prejudicial to the tree upon which it grows. With the discovery of "symbiosis" or that arrangement whereby two plants live in intimate association one with the other without injury to either, but perhaps with reciprocal advantage—a different view has been taken and an Apple tree is supposed to be advantageous to the Mistleto growing on it in summer, while in winter the evergreen *Viscum* supplies the deficiency which the apple experiences by the loss of its leaves. M. GASTON BONNIER has been putting the matter to the proof by estimating comparatively the changes which occur in the composition of the two plants and of the atmosphere during growth. For half the year it is found that the Mistleto assimilates food by its green leaves for the denuded Apple tree. We cannot give the details of M. BONNIER'S experiments, but it is sufficient to say that they completely bear out the idea of perfect "symbiosis," or mutual adaptation, and that save by mechanical obstruction, the Mistleto does no harm to the tree on which it is growing."

VII.—TIMBER AND PRODUCE TRADE.

Statement of average selling rates for timber and bamboos in Meerut, Cawnpore, Bulandshahr, Pilibhit, Bareilly, and Moradabad for the quarter ending 31st December, 1891.

Description.	Timber Scantlings per score.		Bamboos per 100 score.		REMARKS.
	From	To	From	To	
MEERUT.					
Sal 10' Tors (Poles) ...	R. A. P.	R. A. P.	R. A. P.	R. A. P.	
Sal 10' Tors (Poles) ...	10 0 0	20 0 0	
Sal Karris, 12' x 5" x 4" ...	25 0 0	40 0 0	
Sal bed posts, 7' x 2½" x 2½" ...	78 0 0	1,210 0 0	
Bamboos of 9' to 10' per 100 score	25 0 0	80 0 0	
CAWNPORE.					
Sal 10' Tors (Poles) ...	5 0 0	6 0 0	
Sal Sain Karris, 12' x 5" x 4" ...	7 0 0	8 0 0	
Sal bed posts, 7' x 2½" x 2½" ...	2 0 0	28 0 0	
Bamboos of 9' to 10' per 100 score	20 0 0	30 0 0	
BULANDSHAHR.					
Sal 10' Tors (Poles)	
Sal Sain &c., Karris, 12' x 5" x 4"	
Sal bed posts, 7' x 2½" x 2½"	
Bamboos of 9' to 10' per 100 score	50 0 0	50 0 0	
PILIBHIT.					
Sal 10' Tors (Poles) ...	40 0 0	70 0 0	
Sal Karris 12' x 5" x 4" ...	30 0 0	40 0 0	
Sal bed posts 7' x 2½" x 2½" ...	5 0 0	64 0 0	
Bamboos of 9' to 10' per 100 score	60 0 0	100 0 0	
BAREILLY.					
Sal 10' Tors (Poles) ...	5 0 0	10 0 0	
Sal Karris, 12' x 5" x 4" ...	50 0 0	60 0 0	
	25 0 0	35 0 0	
	10 0 0	40 0 0	
	10 0 0	15 0 0	
Sal bed posts, 7' x 2½" x 2½" ...	10 0 0	15 0 0	
Bamboos of 9' to 10' per 100 score	50 0 0	137 8 0	
MORADABAD.					
Sal 10' Tors (Poles) ...	20 0 0	22 0 0	
Sal Sain, &c., Karris, 12' x 5" x 4" ...	30 0 0	60 0 0	
Sal bed posts, 7' x 2½" x 2½" ...	10 0 0	128 0 0	
Bamboos of 9' to 10' per 100 score	50 0 0	100 0 0	

Churchill and Sim's Circular.

February 3rd, 1892.

EAST INDIA TEAK.—The demand remains unsatisfactory, with a consumption of only 842 loads for the month against 1,359 loads in January, 1891, and 1,625 loads in January, 1890. Prices are, nevertheless, quite firm at the improved level reached last autumn; and, with a visible floating supply which, though it may be sufficient for the present reduced rate of demand, is certainly not excessive, there seems no likelihood of any lower rates for the present.

SATINWOOD.—**EAST INDIA.**—*Logs*—are asked for, and good parcels would sell well, but *planks* and *boards* are not wanted.

EBONY—**CEYLON.**—Supplies are needed as the market is bare, and really good logs would realise full prices. **EAST INDIA.**—The demand is steady, and prices are fairly good.

ROSEWOOD.—**EAST INDIA.**—Good wood is asked for, and large sound logs would sell well.

Price Current.

Indian Teak—per load	...	£9-10	to £15
Cedar, Malabar, per sup. ft.	..	3½d.	to 3¼d.
Satinwood, per ton	...	£8	to £12
Rosewood, " "	...	£7	to £11
Ebony, " "	...	£9	to £11

VOL. XVIII]

[No. 4.

THE
INDIAN FORESTER ;
A MONTHLY MAGAZINE
OF
FORESTRY,
AGRICULTURE, SHIKAR & TRAVEL.

EDITED BY

J. S. GAMBLE, M.A., F. L. S.,

CONSERVATOR OF FORESTS, AND DIRECTOR OF THE
FOREST SCHOOL, DEHRA DUN.

APRIL, 1892.

MUSSOORIE :

PRINTED AT THE MAFASILITE PRINTING WORKS
COMPANY, " LIMITED."

1892.

Contents.

No. 4—APRIL, 1892.

	Page.
I.—ORIGINAL ARTICLES AND TRANSLATIONS.—	
<i>A tour through Kamraj-Kashmir (Part 4)</i> J. C. McD.	127
<i>Forest Settlements in India</i> by B. H. Baden-Powell C. I. E.	132
<i>Famine Works in the Madras Forests</i> ...	148
<i>The Stinging Tree</i> , by J. S. G. ...	148
<i>Village Forests</i> , by Tserofski ...	150
II.—CORRESPONDENCE.—	
<i>The Grass Farm at Allahabad</i> ...	154
<i>The formation of Dew</i> ...	155
<i>Fires caused by sparks</i> ...	155
III.—OFFICIAL PAPERS AND INTELLIGENCE.—	
<i>Effects of the Cyclone of November 2nd 1891 on the forests of the Andamans</i> ...	156
IV.—REVIEWS.—	
<i>The Central Provinces Forest Report for 1890-91</i> ...	157
VI.—EXTRACTS, NOTES AND QUERIES.—	
<i>Portraits of Forest Officers for the Nancy Collection</i>	159
<i>The Economic importance of birds in India</i> by W. L. Sclater ...	160
<i>A new method of sawing planks</i> ...	164
<i>Forestry in Ireland</i> ...	164
<i>Death of Mr. John Macgregor of Dunkeld</i> ...	165
<i>Padouk wood in England</i> ...	166
<i>Deterioration of Scotch Fir</i> ...	166
<i>The European C. S. Association</i> ...	172
VII.—TIMBER AND PRODUCE TRADE.—	
<i>Churchill and Sim's Wood Circular of March 3rd, 1892</i> ...	172
<i>Produce Sales, London</i> ...	173
VIII.—EXTRACTS FROM OFFICIAL GAZETTES	

THE
INDIAN FORESTER.

ERRATA. FEBRUARY No, 1892.

Page	52,	line	17,	for	'Guchhiári'	read	'Guchhiáni.'
"		line	36,	for	'drisikari'	read	'drinkari.'
"		and		for	'dresikari'	read	'drenkari.'
"	53,	line	11,	from	bottom		
"				for	'material'	read	'medicinal.'
"		line	6,	from	bottom		
"				for	'substance'	read	'instance.'
"	54,	line	2,	for	'some'	read	'none.'
"	55,	line	27,	for	'sour'	read	'soar.'
"	61,	line	9,	for	'23'	read	'2 and 3'

MARCH, No.

Page	92,	line	2,	for	'Whst'	read	'What.'
"		line	8,	for	'the'	read	'be.'
"		line	21,	for	'routine'	read	'volume.'
"	93,	line	3,	for	'be'	read	'he.'
"	94,	line	4,	for	'feet'	read	'inches.'
"	95,	line	28,	for	'stocks'	read	'stools.'
"	96,	line	16,	for	'Sons'	read	'Sous'
"		line	22,	before	'got'	insert	'I.'
"	93,	line	22,	for	'be might'	read	'might be.'
"	100,	line	13,	for	'rule'	read	'note.'
"	106,	line	9,	for	'in'	read	'is.'
"	109,	line	32,	after	'redgum'	add	'forests.'
"		line	3	from bottom,	after 'with'	add	'in.'
"	114,	line	5,	for	'malabaricus'	read	'malabaricum.'
"	119,	line	21,	for	'botonist'	read	'botanist.'

wooden temple. As usual the tank contains hundreds of the brown fish appertaining to such tanks: they are very tame and come to be fed, but they do not look inviting, and it is a disgusting sight to see the slimy mass struggling over some pieces of food. The water is not safe to drink, the medical authorities stating that it contains worms. There are some fine *Diplazium poly-podioides*, Mett., growing near the temple, the only specimens I have yet seen in Kashmir proper, though it is common in the Kishanganga Valley. At the back of the Tregam village, which is

Contents.

No. 4—APRIL, 1892.

Page.

I.—ORIGINAL ARTICLES AND TRANSLATIONS.—

A tour through Kamraj-Kashmir (Part 4)
J. C. McD.

197

Produce Sales, London 172

VIII.—EXTRACTS FROM OFFICIAL GAZETTES

173

THE
INDIAN FORESTER.

Vol. XVIII.]

April, 1892.

[No. 4.

A Tour through Kamraj—Kashmir.

(Continued from last issue.)

No. 4

The next march was from Dardpur to Tregam ; between the two the road is once more quite in the plain running along at the foot of the hills, which are mostly bare between these places except for a small nearly ruined forest of deodar which should be taken up and allowed to recover. Everything in the shape of deodar forest must be demarcated as state forest and as much as possible closed to grazing. Tregam is a beautiful spot owing to the presence of one of those remarkable springs for which this country is famous ; it has a great volume of water which rushes out with much force and goes to water the fields after filling a rough stone tank that has been made to enclose a space round the main spring. This tank is a large expanse of limpid water overshadowed by some grand plane trees and other trees and shrubs. As the place is sacred, not a leaf or bough is touched, so that there is a charmingly natural look about everything ; and again the wish comes to one's mind "would that there were more sacred places in the forests." At one side of the tank is a picturesque old wooden temple. As usual the tank contains hundreds of the brown fish appertaining to such tanks : they are very tame and come to be fed, but they do not look inviting, and it is a disgusting sight to see the slimy mass struggling over some pieces of food. The water is not safe to drink, the medical authorities stating that it contains worms. There are some fine *Diplazium poly-podioides*, Mett., growing near the temple, the only specimens I have yet seen in Kashmir proper, though it is common in the Kishanganga Valley. At the back of the Tregam village, which is

a very large one, rise some hills once covered with a dense mixed forest of deodar, kail and broad-leaved trees. This was inspected, and the present state of the tract is enough to make a susceptible forester weep tears of vexation. I was perfectly aghast at the destruction I witnessed, for it was evident from the stumps, &c., that it once contained a large number of fine trees, while now there only remain stagheaded, lopped and crooked deodar and a few good kail. It would seem that almost every form of injury that the human mind could devise has been practised here. Thus, almost every tree near the paths, whether deodar or kail, has been barked or hacked and sometimes both; the other species, except walnut, have all been lopped to within some 6 feet of the ground; huge dead trunks (felled by the villagers) encumber the soil in every direction; and, to sum up, fires have swept through the forest and even, as I went along, I counted five dead kail trunks fiercely blazing. The matter was at once enquired into and after a deal of prevarication the villagers acknowledged that the fires are lighted to scare the bears away from the fields. So little thought have these men of the loss they are causing to the State that they are quite content to burn the forest in order to prevent damage to their crops. Charles Lamb's roast pig lately alluded to in the *Forester* was nothing to it! Much injury to forestry has been witnessed on this tour, but such a miserable wreck as this particular tract presents, has not yet been seen. Still, wreck though it be, it is valuable because there is no forest beyond Tregam till Kopwara is reached, a distance of some six miles or more. All must be demarcated and as much as possible strictly closed to all privileges for a lengthened period to allow it to recover; if the villagers are inconvenienced, they have only themselves to thank, they really deserve severe punishment, but this would not perhaps be advisable in the present stage of forest administration. What makes it peculiarly exasperating is that while the forest is State property, the village is part of a private Jaghir and Jaghirdars have no rights over trees in State forests, yet the forest has been destroyed. Leaving this miserable scene, we passed on to Kopwara; as already stated, there is no forest between the two villages, the range trends back in a great curve and is one large grassy blank. The road is quite level and passes through some park-like village greens, with huge walnuts dotted about here and there; then some rice fields which are not at all pleasant to go through, as there is no road, merely a narrow path between two fields; my little mare did not like the muddy places and every now and then would flounder off the path into the field, splashing every one near, so that I generally elected to walk till we left the rice fields behind. It was very hot and dry during the day, hardly cooling down at all till after dusk, and we were frequently tempted to exclaim that in the matter of climate, Kashmir was a "fraud." Still, nowhere in the hills, is it so very cool at 5,000 feet elevation, and the lovely scenery makes one forget the heat and

other vexations. I heard of some travellers during the past season, presumably fresh from England, who dispensed with tents altogether, and the party of a gentleman, two ladies and children, used to put up in the Lumbardars' houses! probably being a novelty, they thought it great fun, but this sort of fun does not suit your old Anglo-Indian; I daresay such houses are cooler than a tent, but they are not furnished from Maple's and are rather over-peopled for general tastes. The village was in shade from an early hour in the evening, owing to the proximity of the range, it was pleasant to sit out on the green and watch village life. There was a small party of village acrobats present, who came and requested permission to perform before the *hakim*, so we got out easy chairs and sat down to see what they could do. The older man was a fine muscular fellow, in splendid training, but one could not help wondering what these simple people would say if they could be taken to see one of the acrobatic troupes in Europe; however, they did their best and were made happy with a rupee. A short excursion was made from Kopwara up the bank of the Pohru (or Lolab) River to the village of Kumrial to look at the forest there. It lies mostly on the left bank of the river, on a steep hill side, which comes directly down to the water; originally it must have been a good forest with a preponderance of deodar, but has been much over cut, and the cleared areas have filled up with shrubs of sorts, so that it will be difficult to re-stock it with pines. There is some young growth in the patches, but no thickets suitable for the supply of the hop poles required, are to be found. On the right bank of the river, at Kumrial, the country consists of small ranges which were originally covered with dense kail (*P. excelsa*) forest, but, as cultivation extended, this has been cut and little now remains; nothing in the shape of compact areas of forest can be selected here. Next morning (12th Sept.) camp was moved from Kopwara, a couple of miles, to Drogmula, which is the principal village in the tract of this name. The Drogmula *ilaka* is in the form of an elongated horseshoe, the ends lying to the N. W., the bend to the S. E.; the shoe would be complete but that the Lolab river has cut its way through the range surrounding the *ilaka* at a point in the S. W.; the Kamil river, which runs in an easterly direction from Shalura, joins the Lolab near the ends of the horseshoe. Below the junction to the W. is a fine isolated hill covered with mixed deodar and kail forest, both on the E. and W. faces; this is called Sirikup in the highest part. Drogmula village lies opposite to Sirikup on the left bank of the Lolab, it is situated in the plain encircled by the horseshoe-shaped range. This range is well covered with forest, in fact is the finest deodar bearing tract in the whole of Kashmir proper, and might, under different auspices, have given an endless supply of timber both for export to the plains and for use in Srinagar, as the Pohru (or Lolab) river which joins the Jhelum, as already stated, at Duabgah, can be used for floating timber for several months in the year.

The forest immediately above Drogmula village is a most deceptive one: from a distance, the hillside appears to be very well covered with nearly pure deodar of good growth, except where fires have made clearances. On going over the tract, it is found that except towards the crest of the range, where there are still some fair trees, the stock is almost entirely composed of distorted trunks crowned with coppice-like stems, the result of early lopping. It is a very puzzling question what is to be done with such forests; they, of course, are to be found all over the Himalayas, mute witnesses of the primitive way in which the forests were treated in the dim past. A villager wanted to build a house, saplings were easiest to cut and carry, houses could be more quickly and cheaply made of them, why go to the trouble of felling a large tree which would take much time to cut up; this is, most probably, the history of these curious forests. In Kashmir, luckily, all trees are valuable, however crooked and mis-shapen, because of the demand for firewood; so that when there is a good stock of young growth, these distortions might be gradually cut out and sold for fuel. Were it not for the feeling of exasperation experienced at seeing the destruction, one might be amused at the utter and childish recklessness displayed by the ordinary villager. In one place there were about twenty dead saplings, killed by a fire not long ago, all straight and sound, and in the centre of this group one poor solitary young tree had escaped the fire; will it be credited that some miscreant had actually cut this one and left all the dry trees. They would have done admirably for his purpose but presumably because they were a little harder to cut from being dry, this solitary green tree was taken and all the dead ones left standing.

There are some patches of young growth here and there in the upper part of this forest, the ground being thickly covered like a field of wheat, with thousands of fine healthy young deodars about two to three feet in height; and there is no doubt, from what is to be seen here and in other places, that when closed to grazing and free from the danger of fires, nature will speedily fill the blank spaces where seed bearers still exist. Opposite Drogmula and at the base of the Sirikup hill, stretches a fine level plateau well covered with a very fair kail forest, which was examined. It will be very valuable for the Srinagar supply. In the centre of this is a beautiful spring called Bubu Nár or bubbling spring, at which a fakir settled down some eighty years ago and in the usual way brought in his relations, who have built several houses. Apparently they cannot be ousted as they have a sanad from a former Sikh Governor, allowing them to live there, but from a forest point of view it is a great pity that they should have been allowed to settle there. Luckily, they have not begun clearing for cultivation and it is to be hoped nothing will prevent the area they are occupying from being carefully marked out and limited. It would be a thousand pities if this really fine bit of forest were recklessly treated as others have been. After examining several other

forests in this locality, a move was made to Kandi, a village a short distance to the S. E. of Drogmula, but still within the horse-shoe. On the road several houses were noticed made of wattle and dab and others with rough plank walls, so it is quite evident that there is no real necessity for the use of such enormous quantities of young trees as has been the custom hitherto. There are some very fair forests to the E. and S. of Kandi village, but, as usual, a great deal of damage has been done; many trees have been killed by fires and many by barking for tanning. Some excellent examples of natural reproduction of deodar are to be seen here, the one hopeful sign in these forests. Near Kandi there is a beautiful spring, known as Narain Nag, surrounded by huge poplar and plane trees near the edge of the forest; a small square tank of cut stone has been built round it and it is evidently well cared for and is considered very sacred. It is curious to find apple trees growing actually among the deodars and bearing fine fruit. Some of these semi-wild trees have fruit of a nicer flavour than the ordinary village apple and they are of a light green colour, not of the rosy red of the others. This is a poor country for ferns, probably too dry, the only interesting one to be found here being *Lastrea thelypteris*, Desv. in swampy places. After a day or two at Kandi we made an effort and climbed up through the forest to the top of the range and dropped down the other side into the Lolab valley, camping at the village of Sogam. This was, for the lady of the party, a very stiff climb for she had to tramp all the way up a mere pagdandi. It was not possible to ride anywhere, indeed the horses were only got up with great difficulty. As the weather was still hot in the day time, we rose with the sun, the only way to enjoy marching at this time of the year, and so could spare the time to go leisurely up to the top. On the way, the scene of a disastrous fire was visited, a melancholy sight; it occurred only a few years ago and swept in a broad line right through the forest almost, to the crest of the ridge probably not less than 500 first class trees were killed, besides others of less girth. An attempt at enumeration was made here some sixteen years ago and the result was that all trees in easy positions, whether large or small good or bad, had a large square of bark taken off them, greatly damaging the tree, and a number was then cut into the trunk; it is said that after working for some little time, the matter was dropped, the official in charge reporting that it was quite impossible to count all the trees.

J. C. Mc. D.

(To be continued.)

Forest Settlements in India.

It is satisfactory to see from the *Indian Forester* for November 1891, that the subject of Forest Settlements is receiving attention, and I have thought that a few remarks suggested by the article (in the number alluded to) might not be unacceptable. In truth, the experience of Europe should teach us, that no part of the work of constituting or building up *forest estates* (for this is the object of the administration) is of greater importance than that of determining all questions of right within the limits of the 'Estate'. Several instances might be cited where, what was once a limited grant or charter to a small cluster of houses or a few farms, has in time grown to be a burden swallowing up the greater part of the yield, and all the profits to the State, of an entire Forest.

In forest constitution, there are two sides to the question—two views in which the forest is to be regarded. In one view, the forest is a part of the earth's surface which is capable of yielding a class of produce, of which timber is often, or usually, the most directly valuable, but which is not the only produce, and not always (under certain circumstances) the most economically important. From this point of view, forest management obliges us to devote our attention to such a theory and practice of silviculture as will enable us to produce to the best advantage what we most want; and as this must be done, on the large scale, chiefly by nature—nature helped, directed and restrained—a variety of systematized (or scientific) knowledge is indispensable. From the other point of view, that part of the country which is the site of those operations of nature and art which are working together, to produce and to maintain, the 'forest,' is necessarily kept apart from those other portions which are utilized in other ways. The forest 'estate' is *demarkated* in some way if it is not fenced or enclosed; and in this state it is regarded as a *piece of property*—an estate of a particular kind—no matter to whom it may belong. Regarded from this point of view, a forest is obviously a kind of property which is peculiar; owing to the inveterate tendency of the illiterate peasantry (in all countries) to regard the forest as *un-cultivated*—as not (to their eyes) the same as an area growing corn, or apples, or cherries, it is particularly difficult to preserve it from depredations of all kinds; people *will* think that because trees, grass and fruits of the wild trees are the produce of nature, *therefore*, it is no theft to take them. It is not felt, that gold and gems are just as much the produce of nature, and that the art and skill exercised in polishing and preparing them are not distinct in kind, from the care and labour that are expended on tending a forest. Special laws have to be made to protect the forests on this account.

There are, of course, many other special features of forest property, regarded as property: for instance, an exceptional liability

to uncontrollable destruction by fire; but these I do not enter into as an immediate subject for consideration.

But while this tendency is, or ought to be, confined to the ignorant and unthinking, there is another thought in the minds of the magistrates and official classes generally: they think that after all, the ordinary run of offences do no harm to the forest. It was very long before officers would realize that forest-fires did any harm. The view is held that careful forest preservation, implying protection against trees, is *only* needed for a very special and a limited class of plantation and for valuable forests of teak and other first class woods. And it is held that for the great bulk of forests, no particular care is needed; and that (of course excepting gross acts of destruction) everybody may be left to take wood, grass, and bark, and to graze cattle freely at all times and in all places, as he pleases; and that though the forest may not, under such free and easy treatment, produce 'gigantic teak trees,' still it will yield, and go on yielding, all that is practically necessary. Such wholly fallacious views were actually put forward by Sir T. Hope, in Council, when the Forest Act of 1878, was under discussion. The original framers of the Act* had no idea that such a use would be made of the Chapter, unfortunately headed "protected forests." Legally speaking, of course, the Act *does* speak of two classes of Forest and gives no indication (in its terms) as to where one class and where the other, should be the object of Government to establish. But the framers intended that the Chapter should be applied to any large area of waste or wooded land, which it would be unwise and indeed impracticable to declare permanent Forest in too great a hurry. It was not then known, how the demands of cultivation would affect large tracts of waste; what influence (for example) railways would have on the 'waste' in such places as the Central Provinces. Why the exact term 'Protected Forest' was made use of, I do not know: but none of us who took part in the work, suspected or foresaw, the mischievous use that would be made of it. Indeed, when Dr. Schlich and I were deputed to Calcutta to offer advice to the Select Committee sitting on the Bill, we found that the intention of the Chapter to afford temporary protection pending the development of circumstances was understood: the fears of the Committee were directed to the point, that the enforcing of *rules* (such as Section 32 contemplated) might affect rights (which we had purposely left unrestricted) in spite of our draft; the Committee were therefore bent on introducing the later clauses of Section 28, to avoid this (supposed) difficulty. In vain we pointed out that the tracts dealt with were *not* 'forests' properly so called—that is permanent estates finally *constituted*;

*It is well known that Sir D. Brandis prepared the draft, with some assistance from me among others, and I am well acquainted, with, and in full sympathy with, Sir D. Brandis' views.

and that, therefore, we did not propose to interfere with *any rights at all*—whatever they might be; we pointed out that, if it were necessary to regulate *rights*, then the forest would have to be ‘reserved.’ The Committee (who, it is needless to say, had not among them any experts,) perceived that if they added a *complete* provision for the *settlement* of rights, there would then be no real difference between ‘protected’ and ‘reserved’ forest; so they adopted the vague general proviso for a general *record* of rights, without any attempt to provide for the settlement of any disputed question, or to say what was to happen if a right was *not* recorded, as very easily might be the case. They hoped, doubtless, that *somehow*, their addition would prevent the rules from operating harshly. But they never took up Sir T. Hope’s line (he was not on the Committee at that time) nor did they question the views of the framers as to the proper use of the Chapter. Sir T. Hope’s idea that the great bulk of forests could be always left under Chapter IV, and only a few choice localities need be placed under Chapter II, was heard for the first time in his speech in Council; had it been generally adopted at any time by the Government of India, it would have made the Act entirely inoperative for any purpose commensurate with the wants of the country. As it was, seeing we could do no good, we obtained leave to withdraw, and our subsequent exertions were all devoted to keeping the mutilated and imperfect Act from coming into force in Madras and especially in Burma, a matter in which we were happily successful.

Thus we have two sentiments, one in the minds of the agricultural population, and one in those of the rulers, which are great difficulties. And I must at once proceed to remark, that (as is usually the case with most errors, however pernicious) either sentiment contains, or is connected with, a copious element of truth; and this is apt to be taken to justify the entire position. As regards the desire of the people to do as they please in all forests, there are, of course, a number of cases in which actual *rights* to take wood, or to graze cattle exist; but there are other (and still more numerous) cases where these objects are of such vital importance to agricultural and pastoral people under the century-old systems of tillage which they have inherited, that they are indispensable; and systems of forest culture *must* make provision for their supply. On the other hand, and as regards the views of Sir T. Hope, views which, in a perhaps less defined form, may influence the best officers,—it is of course true that there are different degrees of “intensity” in forest culture, and that according as our objects differ, the necessary degree of detailed care in silviculture may vary also; but that is the limit of the difference. Now, the majority of officers cannot get rid of the idea that no matter how numerous or extensive the demands on a forest are, no care is needed, in periodically closing any part; no unpalatable restriction need be placed on the quantity or

mode of acquiring it, the *yield will go on for ever* ; as long as produce is only fairly taken, and acts of mischief, as distinguished from acts of mere appropriation,—are repressed. The absolute fallacy of this idea, it is to be feared, will not be established, till our forests are (experimentally) ruined before their eyes; if, indeed (and here is the misfortune) the ruin which is not less sure because it is slow, is not delayed beyond the ordinary official life-time of any one officer.

To this inveterate belief, is unfortunately also to be added, the intense fear of unpopularity and discontent and the dread of the trouble involved in making a really satisfactory enquiry into and settlement of the management of a forest estate ; trouble, I say, not meaning that Indian officers as a rule fear work, but the staff is so small and the pressure of general duty so heavy, that they fear that the time required would be prohibitive.

But reverting once more to the popular sentiment, it is obvious that one must come to terms with all cases of *right*. In constituting a forest which can be managed, so as *permanently* to yield any class of produce (however humble), we have to make provision for the perpetual re-growth of what is taken away : and this always involves—in one form or another—the allowing of a certain time of rest : it may not even require the absolute closing of a large extent of forest ; but it essentially demands closing and rest in *some form*. And the demand is emphasized by the fact, that in a large proportion of our total forest area, the restoration of denuded or deteriorating areas, is the first object. In order then to know when and how we can carry out our ideas of proper management without any interference that can be legally sustained ; and in order also to know, how far the public can derive the profit from the estate,* and how far that profit must go to individuals, parties, or bodies, who are entitled to it not as a charity but as a *right*, we have to separate the rights of the public (*i.e.* of the State) for those of private individuals, communities, &c. For centuries past, in those countries, where the value and utility of forest properties are fully appreciated, it is understood that this process is just as essential to the permanent realization of the essential idea of an *estate*, as is the demarcation which has the double object of defining the limits over which the rights of the State, the forest owner, and the right-holder (as the case may be) extend, and the limits within which the special law of Forest protection, &c. is operative. It cannot be too often

*It is constantly forgotten, that by deriving a proper income or profit from its forests (while maintaining and indeed improving the capital) Government is relieving the entire population from an equivalent amount of taxation. The net yield of the Indian Forests in 1889-90 was close on 73 lakhs of rupees. Had this not existed, Government would have had to raise the same amount by increased taxes. When, therefore, the Government Officers give away large quantities of free produce, they are really making presents to certain persons, *at the expense of the general tax-payer*. I do not, of course, here refer to produce taken to satisfy *established rights*, but to the much larger quantities *given away* in "concessions."

repeated, that no forest is secure which is not 'constituted' so that it can be largely taken care of and reproduced; no forest will go on yielding an undiminished supply of *anything* without some degree of cultivation and care: and in no case can the necessary degree of care—, even if it is only the lowest indispensable *minimum*—be given, unless the limits of the estate are rendered certain by natural or artificial *marks* and unless the rights of all parties concerned, the state, the villages, and all others, are fixed and definite. No doubt if a case can be found where the forest area is large, well stocked, and with conditions favourable to growth, and if the demand on it is small, it may go on very well without such precautions because the demand on it is a mere drop in the bucket; but *such conditions do not practically exist, in any of the settled and populous portions of India*, where Forest Conservancy is of importance.

But in Europe the question of *rights* is a comparatively simple one; and the difficulties that have arisen have been almost confined to the forms of *valuation*, and to questions of defining rights where they were originally granted in vague terms, such as, grazing for the 'cattle of a farm,' firewood for the hearths of a family settlement and the like. The rights themselves were almost always based on ancient charters and grants, or at best on a definite legally prescriptive exercise. They were always 'real' rights as the lawyers call them; that is to say, they were always attached to some 'dominant' estate, a house, a cultivated farm, a school, a hospital &c., for the use of which the right was created. Every right is therefore capable of direct legal proof and of being definitely dealt with on well known principles of law. Moreover, in a more advanced state of social life and occupation, it has become more and more easy to alter an occupation that could not be continued, if a forest right was taken away. If a grazing right was incompatible with the due maintenance of a forest, no hesitation was felt in buying it out, or in making a grant of land equal in value to the right; in either case valuing the right by calculating the money equivalent of a year's exercise, and making the total or capital value to be a certain number of years purchase of the annual value. All these methods and rules have been in the course of time fixed by law. The man must then give up his cattle that he could not graze and either take to cultivating the land grant, or to buying fodder or leasing a grazing with the compensation money. Or again: if he has a number of goats which could not be allowed in the forest, the compensation grant would enable him to turn to some other means of making a livelihood.* In India we have a very different state of things: to take the latter question first (as the shortest and simplest) the conditions of life do not enable people readily to turn to a new

*I do not mean that this is *always* the case. Indispensable forest rights are known in Europe as they are in India, but the possibility of a change is much greater in Europe.

occupation, or to modify their methods of agriculture. If you expropriate a right of 'ráb,' or of getting *humus* manure from a forest, people do not know how to cultivate in another way, nor can they procure artificial or natural manure of another kind with the money offered. The man who lives by his goats cannot go and change his life by establishing a market garden on the plot of land you have awarded him in extinction of his grazing rights; nor if you offer him in a capitalized sum,—twenty times (say) the annual cost of grazing for 100 goats,—can he employ the money in starting himself in a shop or in some trade. These possibilities of adaptation must come slowly with the general progress of the people; but at the same time they are not nearly enough considered; nor are efforts made to make a beginning when they usefully might be.* They would require patience and skill, and, above all, a steady view of the importance of the result, and a determination not to fail. So far as to one of the difficulties; that first stated must now be reverted to. The principal feature to be noted will already have occurred to my readers. We have only a very few instances—quite infinitesimal in number compared to the entire number of cases demanding consideration,—where a definite grant, charter, or even a permission recorded at some early Land-Revenue-Settlement or otherwise granted in writing by a Government Official, is in existence. But rights may be also 'prescriptive,' that is to say, it is a matter of common law—which in principle we may take for granted,—that where a person has for a certain number of years, openly, peaceably, and as of right, *i. e.*, not by stealth, by violence and lawlessness, or by tacit or express permission and sufferance, exercised the practice of taking one part of the produce of a forest, he will be held to have acquired a *right* to that, provided the exercise (besides the above conditions) is not a matter of destruction, that is to say, is not one which continually threatens the very existence of the estate which is destined to bear it, in perpetuity. It is also a necessary corollary of such a principle of law, that where the practice is indefinite, it can be rendered definite and that it can be regulated, so that its exercise should not interfere with a fair enjoyment of the property otherwise. I expressly, in this paper, omit reference to the case of the limitation of rights, where they are beyond the yield-power of the 'servient' forest to supply. At any rate, the legal authorities have the full right to determine

*A glaring instance is afforded by the case of the range of low hills in the Hushyarpur district of the Punjab. No educated forester doubts for a moment that these barren and useless wastes with their "chos" or sand torrents—causing the loss of thousands of rupees annually, could be 'afforested' and restored. Yet for years this work has been neglected and the most unsubstantial difficulties allowed to be raised for fear of the discontent of a limited number of Gujar hamlets, the inhabitants of which still continue to keep some wretched cattle which by consuming every root and blade that appears above the ground in the rains, prevents the restoration of any kind of vegetation. There is no earthly reason, if the matter were *seriously* faced, why the cattle should not be bought up, and the Gujar otherwise provided for.

by legislation, on what principle an undefined right shall be made definite and its exercise regulated. And this is obvious because not only might an undefined right go on growing till its obvious original extent was far exceeded, and the entire value of the forest be swallowed up, *but also because an indefinite right always leads to disputes—which may be as injurious to the right-holder as they are to the forest owner; and lastly, even defined rights must be regulated fairly and equitably in their exercise, because forest management, of *any* useful kind—even the *minimum* before spoken of, becomes impossible whenever indefinite and unregulated rights are numerous. It goes without saying that wherever rights are most numerous, or in other words, when the forest produce gained by them is most eagerly sought for and most necessary, then it is of the greatest importance that the supply should never fail; *and therefore* that the Forest should be so managed or ‘cultivated’ as to secure the continuance of the supply. This proposition can only be doubted by those who still have the lurking belief above alluded to, that (because forest destruction by overworking is a slow process) forests will *always go on* yielding at least common grazing and small wood, without any destruction, except that of breaking up the ground for tillage or wholesale clearing by a fuel contractor.

Now, in India, laws defining the rules of prescriptive right are things of comparatively recent date. There have been ‘Easements’ Acts before 1871, but for practical purposes the Act IX of that year may be taken as the first detailed law. But then it only dealt with that particular class of rights in English law which are called ‘Easements,’† and these only covered a very small portion of the right affecting forests: more indeed concerned with rights of way, the use of water, to the flow of drainage &c. if not the rights of light and air and of ‘lateral support,’ but the entire class of *rights to produce*, such as wood, fuel, grass, grazing, surface soil etc., were ignored. It was not till Act XV of 1877 that the law was enlarged so as to include among the rights which can be acquired by enjoying them “peaceably, as an easement, and as of right, without interruption, for 20 years” that large class

*I allude to such cases as the well known instance, where a right of firewood for a *factory* (then a small one consuming a very limited quantity) had been granted by charter. In after years the factory grew to be an immense establishment requiring thousands of tons of wood.

†In English law, “Easements” were rights which did not imply (generally speaking—for there were some awkward exceptions which I cannot go into) taking away produce or part of the property bearing the right. They consisted in the access of light and air, in the right to receive, or not to receive, drippings of rain and flow of drainage, the use of water, the right of support, *i. e.* of any house by your existing wall or of any beam let into your wall: or of any wall by your not digging out the soil adjoining, &c. They did not include rights to graze, cut wood &c. There was a ‘right of common,’ a *profit à prendre*, &c.

which are in fact our ordinary 'Forest Rights.' The change was effected by enlarging the definition of 'Easement' so as to include in it,—“a right, not arising from contract, by which one person is entitled to remove and appropriate for his own profit any part of the soil belonging to another, or anything growing in or attached to or subsisting upon, the land of another” It has been held by the High Court of Calcutta* that the provisions of section 26 &c. are not exhaustive *i. e.* that though they formally concede the title to a right that has been exercised for 20 years in the manner stated, they do not imply that a right cannot be acquired otherwise or cannot exist upon any other terms, and, on the case in question, the Court conceded a right, where the circumstances seemed to justify it, though the precise terms of Section 26 were not complied with.

This ruling has an important bearing on our work because it acknowledges an unwritten law—of 'equity and good conscience,—or a common law based on general principles—or something of the kind, *in addition* to the formal enactment in section 26.

Now in most Indian provinces, if we review the history of the past—and obscure as that often is, there is no reasonable doubt about *this* feature of it,—we shall very rarely be able to find any—even the oldest and most necessary—'rights' of individuals or village bodies which strictly or at all comply legally with the terms of section 26. Grazing and wood cutting for instance have been exercised, without any limit, other than the wants of the people, for certainly much more than 20 years (exempt of taxes, and this is not without importance—in the case of the many villages that have only come into existence within the last 20 years, on the edge of the 'waste' or forest): the exercise has been open and peaceable; but was it “as an easement”—*i. e.* as a *right* (of the kind defined) a right, not something permitted, not something which a landlord, which a State Officer or some other authority, could in a moment put a stop to? The answer must be, certainly not. I pass over the question whether in truth a *right* can be said to exist if it is not recognized definitely in “common” or “written” law, and if it is not *enforceable* in Courts of Justice. I do not want to go into any refinements or speculations. But what was the state of the land question in the past? In later days, from about the decline of the Moghal Empire, and when the Deputy Governors of Provinces began to set up as independant 'Nawabs' and when the Maráttá chiefs seized on their dominions—say about the begin-

*I think—it may have been some other High Court. I cannot put my hand on the reference: but it can easily be found in a digest or in one of the annotated editions of the “Limitation Act.”

ing of the 17th century,* it is a matter quite beyond question, that the Ruler claimed to be the owner of every acre of land in his dominions. But, even before that, there never was a time, when the 'waste' and uncleared or Forest land was not the property of the Ruler; and *this* right, at least, passed on to and was accepted by the British Government. The Ruler could make, and did make, grants of waste or unoccupied land for reclamation and settlement; or, if he pleased, he kept it for his hunting ground (witness the Maráttá 'Ramná' or hunting ground and the jungles in Ajmere Rájputana and the Punjab kept by Ranjit Singh, and other instances.) Doubtless, in early days, neither Ruler nor his officers required much in the way of formal permission to colonize and cultivate waste; they were only too glad to see it done; because in time, the land revenue (taken in grain) would be thus augmented. The power of the State or the Ruler to make a grant of jungle land was never doubtful; and if it chanced that any people or villages cut wood in the jungle granted, or grazed their cattle there, they would simply have to go, on the grant being issued. In short, every kind of forest-user, grazing, &c. was so exercised that directly the land was wanted, it had to be given up. It was then purely a question of sufferance or toleration of a practice which (until a grant of the land was thought of) no ruler cared about or thought of interfering with. How far such a continuance of practices in any way corresponds to the terms of section 26, I leave the reader to judge. And there is another matter to be borne in mind. When rights in land were definitely adjusted at the first (British) Land-Revenue-Settlements, the reader is aware that (from the point of view of land interest), these Settlements all come under one of two general classes: either (1) an *estate* is dealt with as a whole, whether that estate belongs to one considerable landlord (as in Bengal or Oudh) or to a joint body of village proprietors (Punjab, N.-W. P., C. P.); or (2) there is no landlord-estate, or joint body owning an entire village, but each field or holding is individually dealt with (Raiyatwári Settlements, Bombay, Berar, Madras and those of Assam, Burma, &c., which are on the same general principle.) Now, in the former case, *either* all the adjacent waste and forest was made over to the Estate, or village, as in Bengal and most of the N.-W. P.; and only remote forest tracts, hill ranges, &c., remained as Government waste, *or*—the waste being abundant, some rule was made allotting to each village or other group a considerable area of 'waste,' usually on some rule of "do chendá" *i.e.* giving waste equal to twice the cultivated area. This was done in the Punjab, C. P. and something like it in Jhansi, Dehra

* The Native Chiefs of Indore and all other States as far as I know do so still. In my forthcoming work on the *Land Systems of British India* (3 Vols. Clarendon Press, Oxford) Vol. I page 230, I have given full reasons for thinking that the Ruler did not at first, but only in later days, in the pride of conquest and in asserting independence, claim to be owner of all land whatever.

Dún, &c. There are special cases of hill districts (Kumaon, Kulu, Kangra, &c.) where no such arrangement is made; but putting them aside, it is obvious that as the villagers, &c. mostly cut wood, grazed, &c. in the area near the village, a large number of forest rights (I do not say all) were satisfied and provided for by giving over, absolutely, to the village or Estate the grounds that supplied them. If the people have chosen to break up those grounds and put them all to other uses, that is *their* business: they could not raise the plea of having (on this ground) any *rights* (in any possible legal sense) in other areas. But this does not apply to Settlements in name or in principle, 'raiyatwári': there the 'waste' numbers were all kept in the hands of Government except such as under the names of kúran, bábul-ban, ramná, urudvé, grazing grounds, &c., were reserved for *use* of the village, though remaining Government property and in some cases allotments for 'ráb,' 'warkas numbers' bané (in Coorg) &c. have been specially provided. Still, there are a considerable number of cases where the arrangements made, or the want of suitable arrangements, left it desirable to make provision for certain wants: perhaps the village jungle gave grass and brushwood, but did not contain material for agricultural implements, still less for house-building: and other examples will occur. Now the framers of the Forest law were in this difficulty, it was impossible under the then existing condition of feeling about Forests, to introduce into the Act, any complete details about forest rights such as are understood in Europe: and yet it was felt that the definition of section 26 in the Limitation law would not exhaust the subject; nor would the wider ruling of Court alluded to (though framed long after) cover the case, because, however the Court may have extended its meaning, it is impossible not to suppose that it intended to make the recognition of right depend on *some* intelligible and limited principle of unwritten or general law, borrowed from England or elsewhere: and if it is historically correct that no '*rights*' were ever exercised as of *right*, *i.e.*, the villager would have no redress in a Court if he were told that the land where he grazed his cows had been granted to a Jáárdár and he must clear out, still it could be fairly argued, that as a *matter of custom*, provision did in some way or other, exist, for the villages to get what they wanted. Local Governors in making grants and urging on the extension of clearance for cultivation, would practically respect the lands which were known to be used by certain already established villages or estates, if for no other reason than this, that to interfere with such custom would be to cripple the villages, endanger the health of the cattle and so endanger the share in the harvest which then represented the land-revenue. While, then, it is important to remember, how many such customary rights *have* been provided for and how little right any one has to press any ground of *legal* right, still, I do not think it would be fair, as a principle, in forest settlements, to judge of claims, on any other standard than the following:—

(1). That the village is an old established one—so that *custom* has had time to be established, and that provision was not made for its wants by an allotment of waste land, and that a long established and definite custom to take from such and such forests, certain produce, or to graze in certain localities, is fairly and equitably apparent.

(2). That the produce to be supplied is really necessary.

(3). That it is for the use of the people themselves and not for sale (this is provided by law). There are special cases where certain tribes have been accustomed to collect for sale, certain objects, usually minor forest produce: there need be no objection to recognizing this (Forest Act, Section 13, last clause).

Mere hardship, perhaps occasioned by the peoples' own act, cannot be allowed, *in the first instance, i.e.* in judging of the question of the existence of a *right* to be formally admitted as such. It may afterwards be a question of some concession* of which I am not now speaking.

(4). It is essential to recognize the *right* so that in future it may not grow to dimensions unforeseen: It is just possible to provide in the law, that after the date of declaration, no new rights should grow up unless for special reasons they were formally *granted* or contracted for *in writing* by the Government, (sec. 22). But if a right which now exists, say for fuel for twenty hearths, is so put down as to allow it to grow to fuel (perhaps) for 200 hearths, it is obvious that 180 of them will constitute practically newly grown rights, which it was the express object of the Forest Act to prevent.

There is no possible hardship in such a case: if new comers settle in a village, the fact that they will not have rights such as the older ones had, is, or should be, known to them, and is one of the conditions under which they settle, just as much as is any one of the other local circumstances limiting their enjoyment.

It was extremely difficult in 1878, to get the authorities to agree, to a complete measure, nor indeed were the framers of the Act able then to say what it would be best to enact: some years of experience were needed. But a Forest Act passed under such circumstances ought to have been thoroughly revised after some years, and it is much to be regretted that our efforts to get a proper revision have been unavailing, and that a wretched patchwork in the shape of an Amending Act, (which really does nothing for the main bases of Forest Settlement) was all that could be had.

* It is better to use the term 'concession' for a permission to graze or collect produce, where there is not a *right* recognized. The term often used, *viz.* 'privilege' is not convenient, because, in English law 'privilege' (*i.e.* privilege of Parliament &c.) is used not only to signify a right, but one of a very strong and enduring kind; hence, to use it (in India) to mean a mere favor conceded, would be very likely in time to lead to serious mistakes.

But we must not be too ready to depair, because the Act is not all that we wish it ; we should rather endeavour to make the best of what we have, and if this is intelligently done, it is surprising often to find how much better off we are than a casual or hopeless examination of existing sections would at first suggest.

It should be remembered that we have, (and can insist on) some very important rules ; and the appellate Court, if it does its duty, is bound to enforce them.

- (a) No *new* right to anything whatever, can be acquired ; this is distinctly infringed, if rights are allowed in such a matter, that they grow in size and extent.
- (b) The principle is enacted that rights are for the personal use, or for the service of the person or other institution for which they are allowed—this limits the right to reasonable dimensions and it is expressly enacted that when a person has grass, grazing, wood, fuel, &c. for his own use or for his friends, &c., he is not at liberty to sell the produce or barter it.* These provisions fully enforced will do a great deal.

But the greatest trouble of all is the *definition* of rights. Those which are allowed in nine cases out of ten, will be allowed, as I have argued, on the basis of custom long established, not otherwise provided for, and really necessary. Yet such 'customs' are pretty sure to be *indefinite*, as to *quantity* of wood, &c. area of grazing, *time* of exercising the right, and *mode* of exercising it.

Section 13 went as far as, at the time, was thought practicable. It does require :—

- (1) as to grazing,—the number of cattle.
- " the kind of cattle.
- " the season of grazing.

and doubtless the "other particulars" of the section would include any specification about the locality, or part of the forest to be used, which constitute the 'regulation' of the right, *i.e.* that it is exercised in a fair manner, which while the *right is enjoyed*, does not leave *other interests* out in the cold.

(2) Wood rights (of all kinds, *i.e.* timber, industrial wood for ploughs, &c.) fuel and brushwood, fallen and dead wood or branches, lopping boughs, &c.,—the *quantity* is to be recorded, and such 'other particulars' as the case may require.

As regard (1). How is the "number" to be ascertained ? The "kind" is not so difficult, for it is only necessary to refer to past usage, to show that the different households have cows, oxen or bulls, goats, buffaloes, camels or what. As to number, as the law *requires* the Settlement Officer to ascertain it, and does not prescribe a rule for doing so it will surely be held that the number

* I have already alluded to the (rare) cases where collection and sale of certain produce themselves constitute the right. That has nothing to do with what I am saying.

must be ascertained by any rule which is fair and equitable in itself, under the circumstances of each case. I need only refer to the ordinary books for the rules about cattle 'levant and couchant'—the number required to work a farm of the existing size and under the usual and long continued method of managing it. But one simple rule could be adopted in most cases, and that is to ascertain the number of each right-holder's cattle, for as many years past as may be practicable, and then to deduce an 'average number' of each kind which may be recorded as the extent of the right, or number of cattle annually to be provided for.

As to 'kind' I have only to add, that great effort ought to be made to exclude goats and, of course camels. It was not possible, in 1878, to adopt the Forest law which refuses goat-grazing "notwithstanding all right to the contrary"; but the Indian Act contemplates and this should never be forgotten, *first* that the rights as they exist, *i.e.*, as the officer on judicial grounds finds he must allow, are to be recorded *and made definite*; *second* that for the right so defined it does not follow that it must be fixed on the forest as a matter of course. Sec. 14 distinctly requires the Settlement Officer, to the *best of his ability and having due regard* to the maintenance of the forest, to take *another series* of steps. Now a forest is not *maintained*, if *any* right is allowed to affect it so that it is continually deteriorating into scrub jungle, or becoming barren, and never improving if it is already only scrub jungle. If, therefore, he has a right of goat-grazing to deal with, he is bound to consider *before* he fixes it on the forest, (sect. 14c) whether he cannot follow sect. 14a or b; I say this not because the Act in terms puts a or b before c in any order of preference, but because his doing so is the *only* way in which he can obey the direction of the law to have *due regard* to the 'maintenance of the forest.' This further follows from sec. 15, which explains what is to be done, if a proper regard for the forest would veto the exercise of the right.

I will return for a moment to sec. 15, presently; but here pass on at once to—

(2.) The case of wood rights in all their varieties, and the question of *quantity*. The most civilized way is to make a regular estimate of the cubic feet of planks, rafters or other form of timber; but that is often impossible: and indeed the rough methods of cottage-building in India, render it hardly necessary. It will generally be quite easy to determine by number of stems, the allowance of poles of a certain size, or of mature trees not above or below a certain girth: it will also be often sufficient to provide that a grant is to be issued on requisition, for erection and repair of a given building after inspection, or on a fair preliminary consideration of probable requirements; the grant or order will thus specify the number of trees, the kind and size, &c.

When it is a question of small firewood and brushwood for fuel, it will probably be most practicable to fix the *area* and *locality* which may be cleared regularly, with provision for each cleared strip not to be grazed over afterwards.

In collecting dead-wood, &c., the quantity is defined by the amount existing; all that is needed is to prevent people ringing or otherwise killing trees and then claiming them as 'dead'.

Lopping can be defined as to quantity, by specifying the species of tree, and the height up the stem to which the removal of side branches may be carried, and a proviso that the same tree is not to be lopped oftener than once in two or three years or whatever it is.

In mountain districts, a common tax on the forest resources arises from the fact, that by bad utilization of the timber, much more is asked for than need be. I have known whole trees to be chipped away with an adze each to yield a single rafter or beam. Here efforts should be made to have a supply of saws on loan; and above all to establish a local depôt, and give out rafters, planks &c. in store. The officer in charge would soon learn what dimensions to cut, and for exceptional cases, passes for standing trees would be issued. A very great deal may be done in this way. Nor would it be at all impracticable to make a beginning of a system of delivering firewood in stacks, in some places.

As regards other rights, as gathering *humus* for manure, forest officers have the means of studying how these matters are regulated in European forests, and they should be prepared, on the basis of such knowledge, adapted to local requirements and conditions, to advise the Settlement Officers as to recording the mode of exercise—especially so as to give sections of the forest soil rest in turn.

Sec. 15 has presented some difficulty in practice, not so much on the ground of cost—for in an important forest it is well worth the outlay, but on the grounds already indicated, namely, that money is often no equivalent (and so also a grant of land for cultivation) because the people do not know how to turn to other methods of manuring, or of keeping cattle, or whatever it is: nor are they prepared to give up one form of working for their livelihood and taking to another. But, as I said, the subject is too lightly and easily dismissed: there are many cases, for instance, in which a man might be persuaded to give up his goats and cultivate a plot of land which can be found for him.

It is seriously to be considered, whether even with the provisions we have, Forest Settlements might not be made much better than they are. And it is a fact which I wish to press on the attention of public officers, that *a large number of existing Forest Settlements, are entirely illegal and fail to comply with what is now the law.* As long as people are ignorant, and Forest officers unable to press the rights of the State, this unwholesome

state of things may go on for a long time without finding any noticeable difficulty : but in forest matters the *laissez aller* policy, is of all things the worst. All experience shows, that as time goes on, Forest property becomes more valuable, the tendency is inevitable that such property should become more sharply defined as a special and very important kind or class of property ; and that the owner, on one side, or the right holder on the other, should look out for their legal rights with greater keenness. At last, questions will come into court, and judges will look into the Act, find out what it requires, and there will be serious embarrassment. All rational forest management looks to the future ; it recognizes that while the present yield or income is made the most of, the future and the state of the capital stock, are to be continually cared for and secured. This most obvious principle is infringed with the greatest certainty when rights are dealt with *not even up to the standard that the existing law allows*—however imperfect. I admit the imperfection, but I insist, that what is there is intelligible ; and goes much further than is sometimes thought ; and I insist that in practice the law is *not* being obeyed. This ought to be very seriously looked to or a crop of troubles in the not distant future, is inevitable.

I have to add only a few words on the subject of 'concessions.' There is, of course, a great fear, that because it must take time (and that is more considered, as I said, than trouble) to *define* rights, some officers may be tempted into declining to record any rights at all ; and to stave off the difficulty by representing that 'concessions' which the law does not sanction, and therefore does not place under restrictions as to definition) will do as well ; and they may recommend the executing of them in a worse way, well knowing that the *withdrawal* of these when once made, will easily be resisted. This is a gross injustice to the forest property of the public ; and the time may come when it will prove an equal injustice to those who might have been entitled to real customary rights. For the tide may turn, the administration may be as keen about preserving forests and the rights of the State, as it now is about letting them loose : and in that case concessions may be withdrawn wholesale, or with some tardy settlement which after the lapse of time and the establishment of practices in the course of years, may be extremely disadvantageous to the persons interested.

I submit that *concessions* require as much care as *rights* : and that they should *never* be granted without definition. I would also suggest for consideration, whether *all* concessions should not be by *annual* (or perhaps triennial) 'patta' or written document, which should be required to be regularly renewed without fail as long as it is intended to keep up the concessions. A diligent forest officer would always be able to see that this is done, by calling for and inspecting the "patta" from time to time. Of course every such writing would be dated, and perfectly clear as to the period for

which it is in force, and should, in the boldest characters, indicate that *no right* of a permanent kind is admitted or conveyed by it.

As a matter of *amount*, I may add, it is high time that some definite steps should be taken to *value*, in each Range, Division and Province the amount of forest produce—major and minor—which is annually *given away*. I do not refer to *rights*. Those are not a voluntary loss to the State; I mean, that being *rights*, they are not parts of the existing public property taken away and given to any one: the value to the exchequer of the forest, is the estate as it is, not as it might be if unburdened by determined rights. The value of rights as such, it may be desirable to estimate, for general statistical purposes; but that is not the same thing. Every 'concession' not being a right, is simply a present of a part of the State income, given, at the cost of the Treasury, to A, B, C and D.* It may be highly useful and proper to make the present; but to *ignore* it is essentially to obscure the public accounts.

When we consider how largely forest administration in India is dependent on the fact that it pays its way, it is nonsense to say that the State income is 73 or 74 lakhs a year, when in fact it is 73 paid into the exchequer, *plus* another 73 given away in kind to private persons, villagers, &c. Nor is the fact in the least altered by the fact that the concession may be part of an inducement to colonists to settle and so to benefit the land-revenue. People are often induced to cultivate by the offer of a canal cut, but no one thinks of *not showing the cost of the cut*, on that account.

And I may add in conclusion that if a small fee (which might be in the form of an adhesive stamp) on all commission *pattas* or grants were required, it would be useful as a check. It would also be well if a small, even a nominal, annual rent or '*redevance*' were charged for concessions: it would emphasize the distinction between a concession and right; and it would greatly help in the record of the number and consequent valuation of concessions, the fees, &c., realized being *part* of the value to be recorded.

B. H. BADEN POWELL,

Oxford, 1891.

* This might be said practically to be not the case, when the produce is given to a few local residents, which produce *could* not be otherwise sold, exported or utilized: but such cases are rare.

Famine Works in the Madras Forests.

The *Madras Mail* has several references to what is being done for the supply of grass from the Reserved Forests. The Nellore Collector is "making endeavours to induce the people to 'cut grass in the Reserves and to store it for use; also to construct 'silos and to carry out the departmental storage of hay for 'future sale."

In Salem also, arrangements are being made to cut and stack hay for sale. In Anantapur, some Forest Reserves in Dharmaveram Taluk have been opened for free grazing and others in Tadpatri, Dharmaveram and Penukonda for the free cutting of grass. From Bellary it is reported that the grass supplies of the Sandúr Hills are becoming exhausted and that advances for the purchase of fodder have had to be given to persons wishing to go to them for grass.

Both in Cuddapah and in Anantapur, the walling of Reserved Forests, a most excellent and useful thing, has been started as a famine relief work. Work has begun in the Kalyandrug Reserve in Anantapur. We hear that some work in the replanting of bare hill sides is also to be undertaken in the same way. And our information is also that the excellent system of allowing the free cutting and removal of grass instead of throwing everything open to grazing and the consequent destruction of all young crops, has resulted in a great decrease in the labour of fire-protection.

The Stinging Tree.

In the *Pioneer* of January 28th, the following paragraph fills a corner. Some of our readers may like to hear the plain history of the plant referred to, from one who was personally acquainted with it.

In the beginning of the year 1885, the writer was in Calcutta for a few days, and at the request of the then Governor of Madras, Sir Mountstuart E. Grant-Duff, he arranged with Dr. G. King of the Royal Botanic Gardens for sending down a selection of interesting trees for the beautiful gardens at Guindy Park in which the Governor took so much interest. Among the plants sent down, was one of the *Laportea crenulata*, Gaud, well-known in Darjeeling and other places as possessed of a most dangerous 'sting'; and thinking that at a place like Guindy Park such a plant would be a possible danger to incautious persons and especially to children, the Governor sent it to the Agri-Horticultural Society's Garden, where it was, as described in the *Pioneer*, accommodated with a special railing and a warning notice. This is most probably the plant whose decease is recorded, but why it should not have lived and thriven, it is difficult to say.

It is quite common in the North-East Himalaya and Assam, it extends down to the Western Gháts and Ceylon on one side and throughout Burma, southwards to Perak on the other, and the writer has seen it in abundance in shady woods in the Rumpa country on the Godavari. As he has practically experienced, the sting is a most virulent one and as he was stung on the hand, he can endorse the *Pioneer* writer's statement, that, for some months' afterwards, the pain was perceptible every time he washed his hands. He can remember some of his friends in Darjeeling suffering great agonies from being stung by it on tender portions of their bodies. In the *Himalayan Journal*, Sir Joseph Hooker says: "the great shrubby nettle (*Urtica crenulata*) is held in so great 'dread, that I had difficulty in getting help to cut it down. I gathered many specimens without allowing any part to touch my skin; still, the scentless effluvium was so powerful that mucous matter poured from my eyes and nose all the afternoon, in such 'abundance that I had to hold my head over a basin for an hour." The writer remembers Mr. J. A. Gammie telling him that very similar effects resulted when he tried to obtain the fibre of the plant for a collection which the Government had asked for. Sir Joseph Hooker explains further that the stinging hairs are microscopic and confined to the young shoots, leaves and flower stalks. He says that the French botanist, Leschenault de la Tour, was stung by it on three fingers of his hand in the Calcutta Botanical Gardens and suffered in consequence from sneezing and running at the nose, followed by tetanic symptoms and two days suffering, the effects only disappearing after nine days; and he remarks that, though Endlicher had attributed the causticity of nettle juice to bicarbonate of ammonia, neither he nor Dr. Thomson had found that substance in the *Laportea crenulata*. Sir Joseph Hooker records it as a remarkable fact that its sting is only bad in the autumn. Colonel Beddome says that with natives the sting brings on fever which is certainly not impossible. The tree is called *Chorpatta* in Bengali; *Moringi* by the Nepalese; *Mealum-ma* by the Lepchas; *Phetya-kyee* in Burma and *Maísa* in Ceylon, and it has a soft, rather fibrous wood. To those who can brave the disagreeable effects of preparing it, it would give a strong, useful fibre.

It is not described by Bentham and von Mueller as occurring in Queensland, but they mention three other species, *Laportea gigas*, Wedd. a large tree 80 feet high, whose leaves have a few 'stinging hairs'; *L. photiniphylla*, Wedd., a fine tree of 60 feet, also with 'a few stinging hairs'; and *L. moroides*, Wedd. a tall shrub or small tree with 'most virulent stinging hairs,' which is probably the species which the *Pioneer* writer had in his mind when he wrote.

"THE STINGING TREE.—There is, or rather was—for it is 'dead—a small tree in the Madras Horticultural Gardens called the "Stinging Tree." It grew in a small enclosure in a plot of

'land surrounding the Superintendent's house, to the north of the gardens proper, and was railed round in order that visitors might not come in contact with it. A notice was also put up in the enclosed space warning people against touching it. It led a retired and unhappy life, and after struggling vainly for some years against the rains and the sun, it died a wretched death, and its place will shortly know it no more. The tree, or perhaps it would be more correct to call it, the shrub, is, we believe, a native of Queensland, and is dreaded wherever it is met with. It is probably a species of nettle and its deadly nature has been thus described by a traveller:—I was only once stung, and that but lightly. Its effects are curious. It leaves no mark, but the pain is maddening, and for months afterwards the part which is touched is tender in rainy weather, or when it is wetted in washing. I have seen a man who treats ordinary pain lightly, roll on the ground in agony after being stung; and I have known a horse so completely mad after getting into a grove of the trees that he rushed open-mouthed at everyone who approached him, and had to be shot in the scrub. Dogs, when stung, will rush about, whining piteously, biting pieces from the affected part." Perhaps, after all, it is as well that the *Madras* specimen died!

【J. S. G.

Village Forests. ¶

Under the heading of "Rights and Privileges" in the August number of the *Forester*, the present policy of the Madras Government in regard to village forests was stated at length. Put briefly, the resolution of the Madras Government amounts to this:—

- (1). No village forests shall be formed.
- (2). All Government forests, however great the extent, shall be reserved under the Forest Act.
- (3). The forests are principally to be worked for the supply of small timber, fuel, and leaves for manure for the use of villagers.
- (4). No free grazing or free cutting will be allowed in any reserve, but agriculturists will be allowed to graze their cattle on payment of half fees and to cut wood for domestic and agricultural purposes on payment of ordinary seigniorage rates.

The history of Forestry in France shows that an attempt on much the same lines was once made in that country, and that it failed because the inhabitants of communes adjoining forests, refused to allow themselves to be deprived of what they considered their rights, but which the Government did not admit as such. The result was, *firstly*, that the Government found it almost

impossible to adequately protect their forests, owing to the number of offences committed by inhabitants of the neighbouring communes, who being unable to obtain their customary supply of fuel and timber without payment, by lawful means, helped themselves whenever they could get the chance; *secondly*, that the Government recognised the advisability of considering the privileges formerly enjoyed by the communes, and then naturally followed, *thirdly*, the formation of communal forests.

The Madras Government is not following exactly the above lines, but will eventually be compelled to modify its present policy on one or two points. It admits the admissibility of establishing village forests, but cannot get over the stumbling blocks. A village forest must either be managed by the Forest Department, by the village headmen, or by a punchayet formed of the leading men of the village: at present the Forest Department is too undermanned to attempt the control of village forests; village headmen and the leading men of villages are, sad to say, not to be trusted, if they had power of control, the village forests would soon disappear, and the produce would be utilized or sold by the members of the controlling body, while the small landholders, the very persons who most require help in the shape of free timber and fuel, would obtain absolutely no benefit from the forests specially set apart for their use. But, in time, one or both of these difficulties may be removed; the Department may be strengthened, village headmen may grow honest, or a system by which the distribution of the produce removed from communal forests, or handed over from Government forests for the use of the commune will be controlled by Tahsildars and Divisional Officers, may be brought into operation.

The concessions which the Madras Government proposes to allow, are very small and will not satisfy even the most reasonable ryots. The right to obtain a certain amount of timber and fuel at ordinary seigniorage rates is no concession, for ryots have been able to cut wood free of all seigniorage, for many years, and in no case has the necessity for paying more than the fixed seigniorage rates yet arisen. The half grazing fees for cattle required for agriculture are so small (two annas per head per annum) that they ought not to be the cause of any complaints, but unfortunately bulls and cows are not placarded "For agricultural purposes," "For sale and barter," etc, and it would be impossible to say which cattle were entitled to be grazed at the reduced rate and which were not. If communal privileges are to be allowed they should not cost the commune more than the expenditure which is necessary for the maintenance of the forest area from which the said privileges are to be supplied; there should be no question of seigniorage; the annual cost once fixed, should be collected from the inhabitants of the commune by the village head in the shape of a tax, which being credited to the Forest Department would be replaced by a certain quantity of timber,

fuel, bamboos, etc. and a certain number of grazing tickets. As stated above, the time has not yet come for such civilized arrangements, but as the immediate result of the revised policy of the Madras Government will be the settlement of large areas of forest hitherto excluded from reserved forests, it will be well, if, in order to save both time and money hereafter, the present settlement were made to include certain information necessary for the ultimate establishment of village forests. The Forest Settlement Officer should record, village by village, the concessions which he is of opinion should be ultimately allowed and which have in his opinion, been proved to exist; the nature of the proof required would be the existence of such concession sixty years ago, this being the period of enjoyment of an easement on Government property which is necessary before a privilege can be established. This principle was followed in the settlement of communal privileges in France, where it was held that privileges could only be admitted to the extent to which they existed sixty years prior to settlement, and that they could not grow with the communes to which they belonged; the necessity of this restriction is self-evident, for a village of 100 inhabitants to-day may increase to one of 1,000 inhabitants in twenty years time, and if the forest privileges pertained to each individual in the commune instead of to the commune as a corporate body, the demand on the forest might in time exceed its possibility.

The settlement of these concessions would tend to defer the completion of forest settlement at present, but on the other hand would save the expense and trouble of a separate settlement, say, ten years hence, and would stop the growth of privileges during those ten years; moreover, the actual work in each village would be but little; from village returns sixty years old the Forest Settlement Officer could obtain all the information he needed, and in default of returns of that venerable age, the oldest available would suffice. The record would run something in this style.

—————RESERVE.

—————VILLAGE.

The area reserved in this village is 2,050 acres; the area of waste lands outside the reserve is 543 acres scattered in small patches among cultivated lands; it cannot be counted on for the supply of timber, fuel or grazing (except in the wet season).

Three old men in the village depose to the fact that until within the last few years, it was customary from their childhood, to obtain timber for houses, ploughs, etc., and fuel for domestic purposes, from, and to graze their cattle in, the forests now included in the reserve, and that no payment was ever demanded or expected for such timber, etc. The oldest records available are those of 1861; allowing that the increase in population and cultivation has progressed regularly since 1831, we obtain the following figures.

	Records of 1891.	Records of 1861.	Calculated figures of 1831.
Occupied area	1,250	1,000	800
Population	990	770	595
Land Revenue	1,875	1,500	1,200

At 6 heads per house, this give 99 houses in ... 1831.

At 3 head of cattle per 5 acres of occupied land,
this gives 480 agricultural cattle in ... 1831

Note.—Cattle now graze for three months on waste lands, and are fed on cholum stalks and paddy straw for three months during the cultivating season, so that provision for 6 months grazing only is necessary.

Taking the annual requirements of each house at the prescribed figure, *viz.* 1 ton fuel and 2 cwt. timber, the total requirements are

Timber	10 tons.
Fuel	100
		Total	... 110 tons.

The Forest Officer attending the enquiry, estimates the existing growth in the reserve at 4 tons per acre ; when reserved should increase to 7 tons per acre ; has been much cut over ; annual increment $\frac{1}{4}$ ton per acre, may increase to $\frac{1}{3}$ ton. From this it follows that 440 acres are required to meet the privileges recommended to be established in this village.

The probable annual cost of protection will be $\frac{3}{8}$ of a guard on Rs. 6 = $2\frac{1}{4} \times 12 =$... 27

Forest operations (except labour for felling, etc., which the village must supply) ... 23

Total Rs. 50

This is equivalent to a little under eight annas per ton of wood, etc. per house or exactly 6 annas per ton of fuel and Rs. 1-4 per ton of timber, or a little under 3 per cent on the Land cess of the village.

As one fifth of the above 440 acres will constantly be closed to grazing, the remainder, 350 acres, will be insufficient for the 480 cattle.

With these details on record, Government could at any time commence the formation of village forests without making any further enquiry, and the mere fact of such details being noted at the time of settlement, would considerably ease the work of the Forest Officer, who, in fixing his boundaries in accordance with the orders of Government, so as to include all good forest land, will have innumerable obstacles thrown in his way and innumerable interviews with bodies of grumbling villagers, who have been labouring under the impression that all forest left out of the already constituted reserves, was left out specially for them, and who resent what they consider a breach of faith on the part of Government in extending the reserves. One advantage of fixing the communal requirements as soon as possible, is that the privileges to be provided for are constantly growing, and the longer this settlement is deferred, the greater will be the area of forest required for the supply of wood to the communes.

TSEROFSKI.

II. CORRESPONDENCE.

The Grass Farm at Allahabad.

SIR,

Could you obtain for me further information on the Grass Farm at Allahabad described in the "Forester" for January 1892, page 31. If you are unable to obtain a full account of the working of the farm and publish it in the "Forester," perhaps you would kindly inform me to whom I can apply. The information I require is,

- (1.) Whether grass can be grown throughout the year on a sandy or bare soil.
- (2.) What manuring and other works are necessary.
- (3.) What species of grass thrive best.
- (4.) Whether the grass is sown?
- (5.) Whether hay can be made of the grass and stacked to provide for the hot weather.
- (6.) What are the cost of the various works.
- (7.) Whether the grass is suitable for cattle.
 - (a.) As fresh-cut grass.
 - (b.) As hay.

C. D. THORNTON,

Tinnevelly.

We are sorry we cannot at once comply with our Correspondent's request, but hope that among our readers there may be someone who can supply the information wanted. The article referred to was extracted from the 'Pioneer' as likely to be of considerable interest to our readers and we have, of course, not the smallest idea who was the author. But we will try to get some more information, and if we are successful, will lay it before our readers.

HON. ED.

The Formation of Dew.

SIR,

I have no doubt you will be glad to receive any original observations on the formation of dew.

The other day I was turning over some large stones lying on the ground under the shade of some mango trees and found on the lower side of one of them numerous isolated drops of water. Was this dew? The upper surfaces of the stone and the ground all about were perfectly dry.

A. S.

' Fires caused by Sparks.'

DEAR SIR,

I have only just received my copies of the "Indian Forester" from July last to January, and while looking through them am rather surprised to read the letter in your September number headed "Remarkable instance of a forest fire caused by sparks." If the fire originated as it is supposed to have done, I certainly agree with the writer that it was a very remarkable case.

My knowledge of chemistry is very elementary, but surely there is some mistake here, we can understand fires being sometimes caused by sparks and we can understand sparks being formed by the concussion of flint with steel or iron, but how sparks can be formed by the concussion of flint, or quartz with quartz, as suggested in the case in question, it is difficult to understand. When flint (or quartz) and iron are struck one on the other a small particle of iron is detached by the concussion and as a result of the heat of the shock, ignites and burns in the atmosphere forming some oxide of iron, but how quartz or flint (which is already an oxide and contains as much oxygen as it can combine with) can possibly burn in the air is a puzzle. I have never seen sparks of quartz.

Notwithstanding the opinion formed by 'Forest Ranger' that it was highly improbable that a workman should have been smoking a pipe in the dangerous position described, it seems to me that this would have been a more plausible suggestion than that of the formation of sparks by the concussion of two blocks of quartz, and I think your correspondent will probably agree with me if he reconsiders his letter.

Will you allow me to suggest to your other correspondent F. A. L. who writes in your November number, that it would be better not to admit just yet that the possibility of fires being caused in this manner has "been proved."

20th February, 1892.

E. G. C.

We hope some of our readers will reply, but we may say that some of our friends have tried and found no difficulty in obtaining sparks from two pieces of quartz.

HON. ED.

III: OFFICIAL PAPERS & INTELLIGENCE.

Effects of the Cyclone of November 2nd, 1891, on the forests of the Andamans.

The Inspector-General of Forests has kindly allowed us to make the following extracts from the Report of the Deputy Conservator of Forests, Mr. E. G. Chester.

The Cyclone extended over a belt about 36 miles broad, of which 25 miles North and 11 miles South of Port Blair. The country consisting generally of ridges and narrow valleys, the former suffered most, but the damage done to the forests has been general. On the ridges, it is my opinion that half the trees have been either blown down or have been completely broken off at some distance from the ground; the trees actually blown down account for nearly one quarter of the stock previously standing in the forests; and this damage seems to have extended to all trees indifferently, as far as my observation goes at present. The gurjan (*Dipterocarpus*) have perhaps suffered rather less than others, and it is true that even isolated trees of this genus (which had been left standing in clearings for cultivation) have, in some instances, remained standing, but these are generally trees of exceptionally large diameter.

In the remaining half of the crop, although the trees have not actually been blown down, or had their stems broken, they have been severely damaged, the boughs being broken off and the crowns left with little foliage or young branches.

In some of the more sheltered localities the damage done has been less, but as the storm was not all from one quarter and the wind veered round and came latterly from the opposite quarter from that at which it commenced, very few localities were sheltered.

Seen from a distance, the forests on the ridges have somewhat the appearance of having been burnt in a forest fire; this description, however, can only apply to the upper story, the lower growth being beaten down and tangled down by the debris of the upper.

The plantations have suffered, but not to any great extent. In the regular plantations, that is, in those for which the area was clearfelled and planted, the damage is not very serious, the portions along the edges have suffered from fallen trees and branches from the neighbouring forest; but the plants in the interior, beyond being blown about a good deal and some being broken and blown down, have not generally much suffered. In the plantations in lines cut through the forest, a number of trees blown down across the lines and the debris of fallen branches have obliterated the lines, the but in the lines we have as yet been able to clear, the seedlings have not suffered much.

The principal obstacle to work and to a thorough examination of the damage done is the total obliteration of the paths in the forest. These were merely paths made for dragging out the timber and it will be several months before we can hope to re-open them all. This is the more to be regretted as a large number of logs ready for dragging to depôt are always lying in the forests, and owing to the impossibility of tracing these paths which were of course, only temporary ones, it is extremely difficult to recognize the spots where these logs lie, and when found, it is impossible to extract them, till we can open the paths. The number of logs shewn in our returns as cut and lying in the jungle ready for extraction at the end of October was 4,295. Nearly all these will be ultimately recovered, but in the meantime the work is seriously inconvenienced.

The barracks at Dhani Khari and at Hobdaypore in which the Forest Department convicts live, were blown down, and the necessity for erecting temporary huts for their accommodation and then re-erecting the barracks has interfered seriously with the work of the Department. These barracks are, however, now re-erected, and the coolies are employed on re-opening paths in the forest, on timber extraction and a few on re-clearing the plantations.

The Chatham saw-mill was partly unroofed and the iron chimney blown down. The chimney was replaced and the mill resumed work on the 6th, but the building has not been re-roofed as yet.

IV. REVIEWS.

The Central Provinces Forest Report for 1890-91.

The Central Provinces Gazette of 14th November 1891, contained the Resolution by the Chief Commissioner on the Reports of Forest Administration in the Central Provinces for the year 1890-91. The Reports themselves, which it appears from the Resolution were submitted separately for the first time by the Conservators of the two Circles into which the Province was divided towards the close of 1889, are not however as yet to hand.

The Reserved Forests of the C. P. have now been classified under 3 heads.

Class A. Reserves under, or about to be brought under, strict conservation.

Class B. (1.) Areas selected from time to time as available for cultivation.

Class B. (2). Other areas.

One of the objects of this classification appears to be the restriction of the area of the Forest Reserves which the Chief

Commissioner has no doubt is at present much too large, being nearly $\frac{1}{4}$ of the khalsa area of the province. The exclusion of some 3,000 square miles of culturable land was one of the recommendations made by the Forest Conference which met shortly after the close of the year at Pachmarhi and this recommendation the Chief Commissioner considers by no means unreasonable and the matter has been referred for detailed examination by local officers.

On the matter of the preparation of working plans but little appears to have been done. A special W. P. officer was employed during a portion of the year, but since his transfer the paucity of the staff has rendered the deputation of another officer to this duty impossible.

The punishment returns of the subordinate establishments are stated to be rather more favourable than last year. Proposals have been submitted for strengthening and regrading the Executive and Protective Establishments in accordance with the re-organization scheme and the Chief Commissioner hopes that with better prospects the standard of integrity and general capacity in the subordinate staff will be raised and its tone improved.

The area under Fire Protection rose during the year from 2,887 square miles to 3,235 square miles and the result of the measures undertaken for protection seem to have been generally satisfactory.

The following orders on the subject of limiting the areas open to grazing were issued by the Chief Commissioner in July 1890 :—

(1). Wherever this can be done without causing serious hardship, the exclusion of goats and sheep from fire protected forests should at once be made absolute.

(2). Where the sudden introduction of this rule would cause hardship, as for instance where there are no malguzari grazing lands to which the goats might be confined—the rule must be enforced gradually, notice being given that by the commencement of 1893 it will become absolute.

(3). Similarly, measures should be taken to gradually exclude goats (only) from all A. Class. Reserves intended for the growth of trees—whether fire-protected or not—the exclusion of goats from these areas to become absolute at the beginning of 1893.

(4). All areas in which special reproduction operations are going on must be closed at once (if they are not closed already) to grazing of all kinds.

The number of animals grazed in the Government Forests and the income from grazing have decreased, the former being 2,820,556 and the receipts Rs. 2,82,179 for the year. As all grazing licenses in the Central Provinces are, it is believed, yearly licenses, the figures given above should represent fairly accurately the extent to which the Government Forests of these provinces are used for grazing purposes.

Cultural operations were only attempted on a small scale and the Chief Commissioner doubts whether with the establishments

at their present strength such operations on an extensive scale are possible. The weakness of the establishments seems to be the chief difficulty in the way of progress in Forest Administration in the Central Provinces, a difficulty which we hope will now shortly be removed in some measure at least by the re-organization scheme above referred to.

We are glad to see that a larger expenditure was incurred on buildings than in the previous year, and regarding this, the Chief Commissioner observes, as was done in the last year's resolution, that—"the proper housing of the subordinate staff, especially in the more remote tracts, is calculated to make Forest service more popular and such reasonable expenditure is money well spent."

Departmental operations do not appear to have been extensive but the Financial results of the year seem satisfactory, the surplus of Rs. 5,64,008 being slightly in excess of that of the previous year.

VI. EXTRACTS AND NOTES.

Portraits of Forest Officers for the Nancy Collection.

It may not be generally known that the Forest School at Nancy possesses the commencement of a collection of portraits of the foreign, including English students, who have been educated there. Unfortunately, their book will only take the ordinary carte-de-visite size, but of such they have already those of some 20 Indian Forest Officers chiefly members of the older 'promotions.'

We have been asked to make it generally known that the Director and Professors are very anxious to complete their collection, and to solicit that those who have not already sent portraits will kindly do so. They may be sent either direct to the Director, M. Puton, at Nancy; or to Mr. W. R. Fisher at the Royal Indian Civil Engineering College, Coopers Hill, Englefield Green; or to ourselves.

Some years ago, the Director and Professors at Nancy presented to the Dehra Dún Forest School a fine album with excellent portraits of their staff including M. M. Nanquette, Mathieu, Barré, Bagnérus Puton, and others the whole packed in a handsome walnut wood casket, and this collection will always be interesting to old Nancy men who may visit Dehra.

At Dehra, too, we have commenced a gallery of portraits of officers who have, at one time or another, been connected with the School and the last arrival is an excellent one of Colonel Bailey, R. E., for which our best thanks are due to that officer.

The Economic Importance of Birds in India.

By W. L. SCLATER, M.A.

Birds may be economically considered in two very different ways : first, from the direct point of view of the economic products of the birds themselves ; secondly, from the indirect point of view of the benefit derived from the destruction of noxious insects by birds, which, no doubt, is of very great importance to agriculture.

It has been argued by certain people interested in agriculture that insectivorous birds, which are so directly important as insect pest destroyers, should be protected by law, but the question arises as to whether insectivorous birds are destroyed for their direct products in any quantities which would make it worth while to introduce special legislation for their protection. In considering this question, the first thing to do is to find out what birds are destroyed in any large quantities in India.

There are only two purposes for which this is done—

- (1) For the sake of their skins or feathers, which are exported in considerable quantities.
- (2) For eating purposes.

The following are the principal birds killed for their skins or feathers ; *Herodias alba*, *Herodias intermedia*, and *Herodias garzettita* (Egrets), all of which have in the breeding season a dorsal or pectoral train of what are known as decomposed feathers ; that is, feathers whose barbs are not connected with one another. These feathers are sold and exported in very large quantities and fetch very high prices.

Other birds of the *Heron* family, such as *Buphus coromandus* (the Cattle Egret), *Ardeola leucoptera* (the Pond Heron), *Ardea cinerea* (the Blue Heron), all produce feathers which are also sold in quantities, but not at such high prices as the Egrets proper.

Another bird whose feathers have a certain market value is the Indian Snake Bird *Plotus melanogaster*. The lengthened scapular feathers, which are the only ones sold for export, are also, according to Jerdon, "looked on as a badge of royalty by the Khasias, and were once the badge of one of the Bengal regiments of Irregular Cavalry."

Many of the pheasants are exported in large quantities, more especially the Monaul *Lophophorus impeyanus*. The bulk of the specimens of the pheasants brought down to Calcutta are shot, I believe, in Bhutan and Nepal, and I have been offered as many as a thousand skins at once ; the other pheasants occurring in any quantity likely to be exported are the two species of *Cerionnis* (*C. satyra* and *C. melanocephala*) known as the Sikkim and Simla Argus Pheasants, respectively, though, of course,

they are neither of them the true *Argus*, which is a bird found in the Malay Peninsula only.

The only other birds which to my knowledge are exported in any quantity are the common species of the genus *Palaeornis* to which all the Indian Parrots belong, the Blue Jay or Roller (*Coracias*), the Kingfishers (*Ceryle* and *Halcyon*), and the jungle fowls (*Gallus*). The heckles of the Southern Jungle Fowl (*G. Sonneratii*) are used for making fishing-flies among other things.

For the following list of the birds commonly eaten in India, I am greatly indebted to Mr. Hume's Gleanings from the Calcutta Market (*Stray Feathers*, Vol. VII, p. 479), which not only gives the birds brought to the market in Lower Bengal, but which is also more or less applicable to the whole of India:—

Charadrius fulvus = Golden Plover.
Gallinago stenura = The Pin-tailed Spine.
Gallinago gallinaria = The Common Snipe.
Totanus glareola = The Spotted Sandpiper or Snippet.
Totanus calidris = The Red Shanks or Snippet.
Hydrophasianus chirurgus = The Pheasant-Tailed Jacana.
Nettapus coromandelianus = The Cotton Teal.
Chaulelasmus streperus = The Gadwall.
Dafila acuta = The Pintail.
Fuligula rufina = The Redcrested Pochard.
Fuligula nyroca = The White Eye.
Querquedula circa = The Blue-Winged or Garganey Teal.

The following are birds commonly eaten when shot by European sportsmen throughout India, but are not found anyhow commonly in the Calcutta bazar:—

Crocopus phoenicopterus = *Hurrial* or Green Pigeon.
Columba intermedia = *Kabutar* or Blue Rock Pigeon.
Eupodotis Edwardsii = *Tokdar Sohan* or Bustard.
Sypheotides bengalensis = *Charras* or Florikin.
Grus Antigone = *Sarus* or Sarus Crane.
Ciconia leucocephala = *Manikjor* or Beefsteak Bird.
Calandrella brachydactyla = *Baghaira* or Ortolan.
Pterocles exustus = *Kuhar* or Sandgrouse.
Pavo cristatus = *Mor* or Peacock.
Gallus ferrugineus = *Jungli Murgi* or Jungle-fowl.
Gallus Sonnerati = Gray-fowl.
Galloperdix spadiceus = Red Spur-fowl.
Francolinus vulgaris = *Kalatur* or Black Partridge.
Francolinus pictus = Painted Partridge.
Ortyornis gularis = *Bantitar* or The Kyah Partridge.
Coturnix communis = *Batter* or Gray Quail.

But in a country such as India, where an enormous percentage of the inhabitants are purely vegetable feeders, the number of birds killed for the table (except, perhaps, in the neighbourhood of great towns, such as Calcutta) is insignificant. Of all the birds mentioned in the above list, killed both for their plumage and their flesh, hardly one can be called an insectivorous bird.

The food of the Herons and Egrets consists entirely of fish and frogs; the Cattle Egret perhaps devours a few grasshoppers,

but the bulk of its food consists of fish and tadpoles; the Snake-Bird is entirely piscivorous.

Pheasants only occur at considerable elevations in the Himalayas; they are chiefly vegetable feeders, though now and then they may devour a few insects.

Parrots are all fruit-eaters and do considerable damage in this way. Neither Snipe nor Duck are insectivorous in a true sense of the word.

The following is a list of the purely insectivorous birds :—

Paradoxornithinæ = Crowtits.
 Crateropodinæ = Babbling Thrushes.
 Timeliinæ = Solitary Babblers.
 Brachypteryginæ = Ground Babblers.
 Liotrichinæ = Ioras and Green Bulbuls.
 Dicuridæ = Drongos or King Crows.
 Certhiidæ = Creepers.
 Sylviidæ = Warblers.
 Laniidæ = Shrikes and Minivets.
 Musciopidæ = Fly-catchers.
 Saxicolinæ = Chats.
 Rutilicillinæ = Red Starts and Robins.
 Accentorinæ = Hedge Sparrows.
 Hirundinidæ = Swallows.
 Motacillidæ = Wagtails and Pipits.
 Pittidæ = Ground Thrushes.
 Cypselidæ = Swifts.
 Caprimulgidæ = Goatsuckers.
 Picidæ = Woodpeckers.
 Upupidæ = Hoopoes.
 Meropidæ = Bee-eaters.
 Coraciidæ = Rollers.
 Trogonidæ = Trogons.
 Cuculidæ = Cuckoos.

The following are the birds of mixed diet, partly insectivorous and partly fruit and grain-eaters, in varying proportions :—

Parinæ = Tits.
 Sibiinæ = Sibilas, White Eyes, &c.
 Brachypodinæ = Bulbuls.
 Sittidæ = Nuthatches.
 Oriolidæ = Orioles.
 Sturnidæ = Starlings and Mynas.
 Turdidæ = Thrushes.
 Fringillidæ = Finches.
 Alaudidæ = Larks.
 Nectarinidæ = Sun Birds.
 Dicæidæ = Flowerpickers.
 Phasianidæ = Pheasants.
 Tetraonidæ = Partridges.
 Turnicidæ = Button Quails.
 Rallidæ = Rails.
 Gruidæ = Cranes.
 Otididæ = Bustard.
 Limicolæ = Waders of all sorts.

The following are those birds which live either in or about water and wet places; their food consists of fishfrogs and

tadpoles, aquatic larvæ of insects, and such small animals as fresh water crustaceans :—

Cinclinæ = Ouzels.
 Halcyonidæ = King-fishers.
 Phalacrocoracidæ = Cormorants.
 Pelecanidæ = Pelicans.
 Ardeidæ = Herons and Egerts.
 Tantalidæ = Ibis.
 Anseres = Ducks, etc.
 Laridæ = Gulls and Terns.

To complete the list of birds I have divided the rest of them into the following three groups :—

Carnivorous.

Striges = Owls.
 Accipitres = Vultures and Hawks.

Omnivorous.

Corvinæ = Crows.
 Ciconiidæ = Storks.

Frugivorous.

Eulabetidæ = Hill Mynahs.
 Ploceidæ = Weaver Birds.
 Bucerotidæ = Hornbills.
 Capitonidæ = Barbets.
 Psittacidæ = Parrots.
 Columbæ = Pigeons.
 Pteroclidæ = Sandgrouse.

Of the above lists it will be seen that very few, if any, of those in the list of purely insectivorous birds are to be found among the birds mentioned in the first part of the paper, *i.e.*, those destroyed for plumage or food. With regard to those of mixed diet given in the other lists, it would certainly be unadvisable to protect them, since they may do much greater harm in devouring fruit and grain than they do good in destroying insects, such is specially the case with crows and starlings.

With regard to the time of breeding, most small birds in Upper India at any rate, breed between April and July. Of course there are many exceptions ; but the four months—April, May, June and July—would practically cover the breeding time of nearly all the birds which require protection.

In Southern India many birds breed in December and January, and in the hills the breeding season, as for instance in the case of the Monaul, is in July and August. In the case however of Lower Bengal, the best months are undoubtedly April, May and June. (*Indian Museum Notes*).

A new method of Sawing Planks.

The plank of timber which has recently been exhibited at Humboldt, in California, U.S.A., is the widest plank ever made. It measures sixteen feet in width, and will be despatched in due course to the coming World's Fair in Chicago, where it is to be shown among the natural productions of California. A Belgian inventor has lately patented a machine whereby plants will be able to be made of almost any length by a process of what is practically unrolling the tree. A tree, having been sawn into logs of three feet wide, is softened in immense boilers, and then placed against cutting machines. The knife of the cutter is a yard broad, and against this the log is made to turn on its own axis with great rapidity. Entering the soft wood the knife cuts from it a plank or sheet of wood varying in thickness from one-fifth of a millimetre to fifteen millimetres—according as it is gauged. The sheet cut off passes through a slot at the back of the knife in one continuous piece, its length being determined by the girth of the log, and the thickness of the sheet, and its breadth by the length of the log, which at present is never more than a metre, the inventor not having as yet a wider knife in use. These sheets of wood, of great length, are unrolled from a cylinder of timber barely able to produce planks of three to four decimetres in width in the ordinary way.

Forestry in Ireland.

Mr. Dermot O'Connell Donelan, who has made re-afforesting a special study, has addressed a letter on the subject to the *Irish National Press*, in the course of which he says:—It will be well to bear in mind that the congested districts are also the districts of the waste lands. These wide extents of bog stretching along the west coast are in Ireland what the same wastes were some fifty years ago in the south of France. For centuries the utilisation of the "Landes" was considered impossible. As in the case of the bogs, there were difficulties in the way, which were regarded as insurmountable. Agriculture had been tried and had failed, and "the Landes appeared doomed to everlasting sterility." At length the Government undertook the work of reclamation, and in 1882 the *Department des Forêts* concluded its report with the words: "Where thirty years ago there were but a few thousand poor and unhealthy shepherds . . . there are now villages with saw-mills, wood-working factories, charcoal kilns, and turpentine distilleries." As timber has become one of the most important prime materials, planting waste lands seems to offer the surest means of solving the question of the congested districts. In Germany the timber manufactures have become so extensive that a sixth of the whole population depends on the forest industries, and the point in this connection, which is of greatest importance to the Congested Districts Boards, is that very young wood is employed as the raw material in several extensive manufactures.

Practically, all paper is now made from wood, and trees for the purpose are old enough at 12, and are at their best before they reach their 25th year. But it is self-evident that to be of any value whatever for economical purpose, a forest must be of sufficient extent to enable manufactures to count on a constant and steady supply of the prime material. We want, therefore, a wood plantation of some 12,000 acres in Connemara. The existence of a timber trade in the locality will then make it possible for private owners to continue the work of afforesting the adjoining tracts of bogs. The acreage actually planted by the Government in Gascony did not exceed 400,000 acres, yet there were 1,200,000 acres in 1889 in the Department of the Landes alone. Commenting on this letter the *National Press* says :—The scheme is especially desirable, in that it not merely increases wealth, but encourages industry. Every year those trees grow is an addition to the reserve wealth of the country. Meanwhile, the preparing of the ground, the planting, rearing, tending, thinning of the trees would bring work, wages, and food to the doors of the peasants in the congested districts.—(*Timber Trades Journal*).

Death of Mr. John Macgregor, Ladywell.

We regret very much to observe that Mr. John Macgregor, head forester to His Grace the Duke of Athole, died at his residence, Ladywell, Dunkeld, from the effects of influenza after an illness of three weeks. Mr. Macgregor was one of the best known and most highly respected men in Athole, and by his removal many a one has lost a true and kind friend. His position was a very important one on the Athole estate, the vast woods and forests of which were at once his pride and his peculiar care. As a practical forester it is not too much to say that he had few superiors in Scotland, and the nursery of young trees at Ladywell was visited professionally and admired by foresters from all parts of the kingdom. Mr. Macgregor was one of the Board of Examiners in the forestry department of the Highland and Agricultural Society. His acknowledged ability on the subject of forestry led proprietors over almost the whole of Scotland to appeal to him for advice, and there were very few large estates from the Moray to the Solway Firths which Mr. Macgregor had not visited for purposes of valuation, laying out for planting, or of giving advice on the treatment of trees. He was particularly kind to deserving young men in his employment, and hundreds have been appointed to places as local foresters on his recommendation. In his own neighbourhood Mr. Macgregor was held in high estimation. He was the perfect type of an ardent and patriotic Highlander, an official of the Clan Gregor Society, and a member of numerous other societies, local and national. He was a man of warm heart, and of wide intelligence and genial manners. For nine years he was a member of Little Dunkeld School Board, and during the greater part of that time he was Chairman.—(*Ibid*).

Padouk Wood in England.

It is interesting to see, as the following extract from *Timber* indicates, that Padouk, that comparatively-recent addition to the exports of India is coming into favour in the North of England:—
 “The handsome building recently erected as a pharmacy for Mr. Joseph Roberts, Bigg Market, Newcastle, has been fitted up expressly by Messrs. John Curtis and Sons, the well-known Leeds firm of cabinet and shop-fitting makers, with a large quantity of this new import. The effect produced by the use of polished Padouk for windows, doors, and easings is unique. In addition to the exceptional design and elegance of Messrs. Curtis’s work, the colour and figure of the wood is all that can be desired. After a careful inspection of this beautiful mahogany of Burma it is difficult even for a connoisseur in fancy woods to forget that he is not looking at the richest and most perfect example of Spanish wood. We understand that Messrs. Curtis and Son are also using Padouk for other contracts they have on hand which will no doubt tend still further to illumine the greater merits of this useful eastern product.—(*Pioneer*).

Deterioration of Scotch Fir.

BY A FORESTER.

If we suppose there are from two to thirty distinct varieties or sub-varieties of Scotch fir to be found growing among our plantations, and that from one to twenty-nine of these varieties are not only short-lived, but of such a nature as to produce a very inferior quality of timber; and if cone collectors are so recklessly careless as to collect the bad as well as the good, and give to our nurserymen a mixed inferior quality of seed; and if the nurserymen are in the habit of importing Continental seed collected from trees inferior in quality to our own, to produce plants which may, when grown up, produce a hybrid seed, to hybridize in their turn our already degenerating Scotch fir, are not these statements almost too dreadful to be contemplated? And if they are really *fact*, must they not also be highly injurious to our country’s well-being? But let us ask, is there any just cause for all this alarm?

True, the Earl of Haddington, in his able “Treatise on Forest Trees,” published in 1760, says, “When I cut firs that were too near the house, there were people alive here who remembered when my father bought the seed. It was all sown together in the seed-bed, removed to a nursery, and afterwards planted out the same day. These trees I cut down, and saw some of them very white and spongy, others of them red and hard, though standing within a few yards of one another. This makes

me gather my cones from the trees that bear the reddest wood." From then until now there have been no end of conflicting opinions advanced upon this subject; even that very practical, shrewd, and keen observing forester, Dr. Brown, in his second edition of "The Forester" published in 1851, says, "There are 'two varieties of the Scots pine, the *Pinus sylvestris* and the 'variety *montana*, which is the true Highland or 'bonnet fir.'" The late Mr. Don, of Forfar, says, that "the *Pinus sylvestris* ' *montana*, or true pine, is distinguished by the disposition of its 'branches which are remarkable for their horizontal direction, and 'for a tendency to bend downwards close to the trunk. The leaves 'are broader and shorter than in the common kind, and are distinguished at a distance by their much lighter and more beautiful 'glaucous appearance. The bark of the trunk is smoother, than in 'the common kind, cones are thicker and not so much pointed. The 'plant is also more hardy, grows more freely in almost any soil, and 'quickly arrives at a considerable size." Of the truth of this assertion of Mr. Don's I am perfectly satisfied, although many botanists will not allow that these two species are really distinct. They say that soil and situation have the affect of changing, in a great measure, the external appearance of this tree; but those who so assert cannot have had much experience of the matter. I have myself seen, and that frequently, the two distinct kinds growing in the same plantation, and close to one another. Now, were it the case that soil and situation changed the external appearance of the trees, why were they found to have different external appearances when growing upon the same soil and site? Although Mr. Don, in his third edition, says, "that before he was thoroughly acquainted with the character of the Scots pine, he was of opinion that there were two distinct varieties, but greater experience had taught him that the seeming varieties did not hold good during all stages of the plants that assume them, and that they are merely accidents of site and soil,"—but still this great evil according to Mr. McLaren is going on, just because most of our proprietors and their foresters fail to properly see and understand its ruinous effects, and therefore the nurserymen find a large and rapidly increasing demand for plants, with which they are always only too glad to supply their customers, without any particular selection of the best variety, so long as orders are fulfilled and no complaints made.

Treating of the Scotch fir, Professor Selby, in his "British Forest Trees," published in 1842, says, "Its geographical distribution is very extensive, being found in Europe, from the Mediterranean on the south, to latitudes as high as 70° on the north, and from Spain and Britain on the west, to Siberia in the east. It also occupies regions in the north, the east, and west of Asia. In the more southern parts of Europe the zone it occupies extends to a greater elevation, being in some countries upwards of 4,000 feet, while in the colder regions of Norway, Lapland, &c., it only

reaches to 700 ft. above the level of the sea. Widely dispersed, however, as the species is found throughout all the mountainous regions of Europe, within the limits of its appropriate zone, it is between latitudes 52° and 65° that it is met with in the greatest profusion, and becomes the prevailing trees. Thus upon the extensive plains of Poland and Russia, it occurs in forests of immense extent, as well as in Northern Germany, Sweden, Norway, and Lapland.

Then Mr. Loudon, in his "Encyclopædia of Trees and Shrubs of Great Britain," also published in 1842, says, "Like all trees which have an extensive geographical range, and grow on almost every kind of soil, and at great elevations, as well as in plains, the varieties and variations of the Scotch pine are exceedingly numerous, both as respects the exterior appearance of the tree and the quality of its timber and resinous products. On poor soils, at great elevations, it becomes a diminutive shrub; and in low situations, where it is a lofty timber tree, the wood on some light sandy soils is white, almost without resin, and of little duration; while on other soils, of a colder and more substantial nature, it is red, heavy, and of great durability. It appears also that the same situation will produce both white-wooded and red-wooded trees; and seeds from red-wooded trees will, it is said, in some instances, produce others, the wood of which is red."

Again, Mr. Grigor in his "Arboriculture," published in 1868, says, "Several instances are known of plantations grown from seeds during the last century from the celebrated native forests on the Spey, and although they occupy soil of various qualities, the timber in all these woods has been famed for its quality, while in several instances, adjoining woods of the same age, and on the same description of soil, grown from degenerate plantations, yielded wood very inferior, the march boundary of the lands sometimes forming the line between the good and bad timber. Numerous instances of the propagation of this tree from different sources tend in every way to establish the fact that this tree, by cultivation for several generations, is very apt to become degenerate; and as it not only yields cones most abundantly at a low altitude, in a district uncongenial to its best form of development, but also produces them at a much earlier age than in the High-lands, degeneracy is thereby accelerated throughout the country."

Mr. Grigor explains the lesson of degeneracy by reminding us of something connected with plant life, of which but few are ignorant, thus:—"The natural law of deterioration appears to be somewhat general; the finest variety of wheat obtained from the genial climate of the south, when sown in some of the more unfavourable parts of North Britain, generally produces a good first crop, but the experience of the agriculturist tells him that the variety changes, and that it is more profitable to renew the stock than to continue to produce from the seed of his own growth."

From the foregoing statements it must be admitted as a fact that there are two varieties of Scotch fir to be sometimes met with in our plantations, one with a redder bark, and a larger proportion of red or hard wood than the other, and that those varieties divide themselves, so to speak, into sub-varieties. A friend who was an enthusiastic naturalist betook himself to finding out the different kinds of Scotch fir in a plantation of irregular and exposed surface, and of very variable soil; and he alleged he found not thirty varieties or sub-varieties, as M. de Vilmorin has experimented upon, but at least three hundred, the difference in size, shape, colour, and roughness of cone, leaf, branch, and bark of which he described with too much minuteness for me to easily follow him. The following day we went off together to see the discoveries he made, and when near the place I asked him to climb into a tree close by us which stood alone, and very much exposed to prevailing winds, and see how many varieties he could get there. Here he greatly surprised himself by finding about as many among the branches and sub-branches as he had the preceding day found among the trees. My friend naturally came, at last, to the conclusion that he mistook "sports" for varieties, and, in going carefully over the ground again, he found that where soil, shelter, exposure, and thinning were the same, nature indulged less in "sports."

My experience is quite at one with the opinion expressed by Mr. McLaren, in so far as that timber of the best quality may be found growing on ground by no means hilly or moorish, but level and clayey, but what kind of clay? Certainly not that which is as free of oxide of iron as pipe or some kinds of fireclay, but *red brick clay*.

It would be seen that great stress was put on the fact that trees have been found growing near to each other so different in colour of timber as to be taken for varieties. I remember some time ago having to do with the cutting down of a wood which had been planted in 1740, a great part of which grew on a whitish clayey soil, and another upon an open moorish soil of red gravel, both descriptions of soil running somewhat into each other. Where the clayey soil was of the purest nature there was to be found the least amount of red heartwood; whereas, upon the other soil, the timber was nearly all red, like best Baltic redwood pine.

With a mere cursory glance at the extracts herein given, one might be inclined to think that after all, varieties of soil had but little or nothing to do with the cause of Scotch fir being found in varieties and sub-varieties, because have not these eminent authors said so and so? I would, therefore, remind your readers that *soils* were great mysteries to all, and consequently agriculture little more than a mere nursling, until in 1840, when Liebig, the father of agricultural chemistry, led the way in unfolding her marvellous treasures, succeeded by others no less eminent; and that the

authors I have quoted penned their statements before much was known about Liebig or his wonderful discoveries; and that Dr. Brown, who was in a position to know best, perhaps, about these questions concerning trees, saw, when writing his third edition of "The Forester," the faulty statements which he had made in his second edition regarding the Scotch fir.

I do not see how nurserymen are likely to give us bad seed from bad cones, because they know very well that the seed produced from small badly coloured cones is so insignificant as not to pay for the collecting of them, not to speak of carriage, the extracting of the seed from the cones, and other expenses.

Mr. Grigor, from whose excellent work we have already quoted, says of Continental Scotch fir (page 162),—"A succession of unfavourable seasons since 1860 has occasioned a great scarcity of Scotch pine seeds, and consequently of young plants of the native tree of this country. This gave rise to large importations of the seed from the Continent, from which plants have been grown very extensively throughout Scotland. These plants are utterly worthless, except in the most favourable situations. In the most sheltered nursery-ground they seldom survive the second winter without showing the influence of frost; and unless protected in early winter they generally become quite brown by the spring of the year, and unsaleable. This is a fact well known to Scotch nurserymen, and to many in England whose nursery-grounds stand elevated and exposed. The difference between the plants of the native Scotch pine and the Continental *P. sylvestris* is quite perceptible when one year old, but much more so at the age of two years; then the two sorts brought into view on elevated ground standing side by side could readily be distinguished at a mile distance, so great generally is the contrast in colour; the foreigner has a dead and withered appearance, while the native plant stands green and scathless. Plants from imported seed have also the disadvantage of forming bare roots, and are on that account more difficult to transplant in safety; therefore, to treat the plant skilfully, it should be transplanted at the age of one year, which will have the effect of giving it a more fibrous root, and of retarding its upward growth, which has the effect of diminishing the influence of frost to some extent during its nursery management. The upward growth of foreign Scotch fir, however, in good shelter and in a favourable climate, is more rapid than that of the native plant. This is very decided in early life, but their girth is generally less, and at last the tree assumes the tall slender appearance which I have observed conspicuously in the planted pine woods of Germany even where the trees had ample space. Some young plantations found in the Highlands of Scotland, made with plants from foreign seed, suffered so severely by the summer frosts of 1863, that the succeeding summers have not restored their vigour, while the native plants have stood exempt from injury."

I quite agree with all that Mr. Grigor says, but I contend that the failure was due to mismanagement, and not the seed. I have seen ground manured for Continental seed, just the same as if for a crop of turnips, and upon which it was sown in the usual way, but the plants thus produced were exactly as Mr. Grigor describes them. Here are seeds matured in a hotter climate and a drier atmosphere than our own, and consequently possessing a much more excitable temperament than our home-grown seed, put into soil purposely prepared to stimulate their excitability, thereby making them grow with too little root, and far too large and soft a top, containing too little woody fibre and too much moisture, consequently making them so much less capable of withstanding the blasting effects of a keen drying cold wind, and the disintegrating influence of a sharp frost, with impunity.

Not being able to understand why foreign Scotch fir seed should not do in this country as well as foreign larch, spruce, and other tree seeds, if properly treated, we tried a little German seed three years ago, plants from which we planted early last spring in high moorish soil, along with the true native pine of same age, and both are doing well; besides, we have one and two years seedlings alongside of the true native of the same ages doing equally well. We are now trying an experiment with Haguenuau, Riga, and true native Scotch fir seeds, thus: In May last we prepared some soil, rich enough to grow a poorish crop of oats, and, after having it well mixed, we filled with it three equal sized boxes, and took them up to the top of a hill about 800 ft. above sea level, freely exposed to all winds. Here we dug a hole, into which we plunged the boxes in the usual manner, then sowed the seeds, one sort in each box, and finished by fencing the place all round, so that neither birds nor deer could get near to interfere with the seeds. The three sorts are, so far, getting on equally well.

It is to be hoped that some of your numerous readers will not fail to try some experiments this season with these three different varieties of seeds, making it a point to have each and all treated alike, and give us details of the results arrived at in a future number of the *Journal*.

Native Scotch fir seeds, like all other seeds, are good or bad, scarce or abundant, according to the season. Now if it can be proved that Continental good seed, under proper treatment, can produce plants that are as hardy as native seed, and that can accommodate themselves as readily to all soils and exposures, it would be a great gain, both to landed proprietors and nurserymen, seeing that when home seed is scarce, Continental seed may perhaps be bought at from one-half to one-fourth the cost of the other, thereby enabling nurserymen to sell their plants cheaper.—(*Timber Trades Journal*.)

The European C. S. Association.

We are requested to make it generally known to our subscribers that the name of Mr. J. L. Pigot should not have appeared on the the list of members of the Central Committee of the European Civil Service Association and on the voting papers which were sent out for the election of those members. Mr. Pigot has had to intimate to the Association his inability to serve.

VII.—TIMBER AND PRODUCE TRADE.

Churchill and Sim's Circular.

March 3rd, 1892.

EAST INDIAN TEAK.—The dock deliveries for the first two months of this year have amounted to 1,725 loads, against 2,859 loads in 1891 and 2,498 loads in 1890; while for February only they have totalled 883 loads, 1,500 loads and 873 loads respectively in the three years. Prices have hardened during the month.

ROSEWOOD.—Large, good logs are asked for.

EBONY.—For good wood there is a fair demand.

Price Current.

Teak—per load	...	£10-10s.	to	£15
Cedar, Malabar, per sup. ft.	...	3½d.	to	33-¾d.
Satinwood, per ton	...	£8	to	£12
Rosewood,	" "	£7	to	£31
Ebony,	" "	£9	to	£11

THE TEAK MARKET.

Messrs. Denny, Mott, & Dickson's report dated the 1st inst. says:—Deliveries from the docks in London last month were 893 loads, as against 1,471 loads for the corresponding date of last year. The landed stocks stands as follows:—

		1892.	1891.
		Loads.	Loads.
Logs	...	8,810	8,234
Planks	...	2,587	1,526
Blocks	...	103	86

The consumption is probably checked by the higher prices now ruling; but ample as the landed stocks are, the floating supplies continue so abnormally small and the stocks at the shipping ports so short that the position of holders must continue a very strong one throughout the year; seeing that the next autumn's supplies from the forests cannot commence to reach Europe until next year.

Messrs. Hoar and Brown report as follows:—

	Timber.		Plks.		Blks.		Total.
	Lds.	Lds.	Lds.	Lds.	Lds.	Lds.	
Stock, 1st February, 1892, ...	9,134	2,583	94	11,811			
Landings ...	394	179	9	582			
	<u>9,528</u>	<u>2,762</u>	<u>103</u>	<u>12,393</u>			
Deliveries ...	718	175	—	893			
	<u>8,810</u>	<u>2,587</u>	<u>103</u>	<u>11,500</u>			
Stock, 29th February, 1892,	8,810	2,587	103	11,500			

Since our last a considerable amount of business has been transacted, and the position appears much brighter now that a large proportion of the cheaper stocks has been cleared off. Tonnage taken up and to arrive is much below the usual quantity and this with the fact of the Admiralty orders for the year being large is sufficient to guarantee a firm market. The docks are fairly well stocked for present known requirements, but should any unforeseen demand arise, a considerable advance may be anticipated.

The stock consists largely of Bangkok timber, which closely competes with both Moulmein and Rangoon shipments. The late Bangkok importations have been exceedingly good, and with a continuance of the care and attention which is now given to the manufacture and selection of the timber these shipments ought to meet with much favour among consumers.

The plank market is not improving, and, considering the enormous stock now here, any increase can only force prices down.

PRODUCE SALES, LONDON.

(*Tropical Agriculturist for 11th February, 1892.*)

Croton seeds	per cwt	15s.	to	24s.
Cutch	" "	24s.	to	34s.
Gum Arabic, Madras	" "	15s.	to	50s.
Gum Kino	" "	70s.	to	72s. 6d.
India Rubber, Assam	" lb.	1s. 6d.	to	2s.
" Rangoon	" "	1s. 7d.	to	1s. 9d.
Myrabolams, good, Bombay	" cwt.	11s. 3d.	to	13s. 6d.
" Jubbulpore	" "	10-6	to	11-6
" Godavary	" "	10-6	to	11-3
Nux Vomica—good	" "	10s.	to	11s.
Orchella	" "	20s.	to	25s.
Red wood	" ton	£3	to	£3-10s.
Sandalwood—logs	" "	£35	to	£60
" Chips	" "	£9	to	£30
Sapan wood	" "	£4	to	£7
Tamarinds	" cwt.	10s.	to	12s.



VOL. XVIII]

18
[No. 5.

THE
INDIAN FORESTER ;
A MONTHLY MAGAZINE
OF
FORESTRY,
AGRICULTURE, SHIKAR & TRAVEL.

—♦♦♦—
EDITED BY

J. S. GAMBLE, M.A., F. L. S.,

CONSERVATOR OF FORESTS, AND DIRECTOR OF THE
FOREST SCHOOL, DEHRA DUN.

—♦—
MAY, 1892.

—♦—
MUSSOORIE :

PRINTED AT THE MAFASILITE PRINTING WORKS
COMPANY, "LIMITED."

—
1892.

Contents.

No. 5—MAY, 1892.

	Page.
I.—ORIGINAL ARTICLES AND TRANSLATIONS.—	
<i>A tour through Kamraj-Kashmir (Part 5)</i>	
J. C. McD.	175
<i>The Germination of Teak, by S. C. Moss</i>	178
<i>The Double Coconut of the Seychelles Islands, translated from the 'Révue Agricole' of Mauriti- tius, by A. S.</i>	181
<i>Cutch and its adulterants, by F. J. Branthwaite</i>	184
<i>Obituary, A. J. Mein and W. E. D'Arcy</i>	185
II.—CORRESPONDENCE.—	
<i>A Department Blazer, letter from L.</i>	186
<i>'Fires caused by Sparks'</i>	186
III.—OFFICIAL PAPERS AND INTELLIGENCE.—	
<i>The Dehra Dun Forest School, Distribution of prizes and certificates</i>	187
<i>Forest products used in Soapmaking</i>	189
<i>The Forest Budget of 1892-93, extract from the Finance Minister's Statement</i>	190
<i>Budget Estimates of the Forest Dept. for 1891-92.</i>	191
IV.—REVIEWS.—	
<i>The Agricultural Bureau of South Australia</i>	191
<i>The Madras Forest Administration Report for 1890-91.</i>	192
<i>"Inventions"</i>	195
V.—SHIKAR.—	
<i>Destruction of a rogue elephant in the Dún, by Rajah Runbeer Singh</i>	196
<i>A tiger killed by buffaloes</i>	198
VI.—EXTRACTS, NOTES AND QUERIES.—	
<i>Growth of planted trees in Assam</i>	198
<i>Aloe fibre</i>	199
<i>Eucalyptus Oil</i>	201
<i>The Teak trade of the Laos States</i>	203
VII.—TIMBER AND PRODUCE TRADE.—	
<i>Selling rates of timber in the N. W. Provinces, on 31st March, 1892</i>	204
VIII.—EXTRACTS FROM OFFICIAL GAZETTES	

THE
INDIAN FORESTER.

Vol. XVIII.]

May, 1892.

[No. 5.

A Tour through Kamraj—Kashmir.

(Continued from last issue.)

No. 5

The Lolab is one of the most beautiful valleys in the Kashmir province; it may be briefly described as a broad circular plain, almost entirely shut in by forest clad hills, which rise directly from the level ground; in most cases the trees beginning at the very foot of the hills. There are many villages in the plain and nearly all the land is under cultivation except near Sandigam where there is a large swamp. The plain has a total length of about seven miles and is perhaps two miles broad in places; it runs from S. E. to N. W. and has a narrow outlet at the Northern end; the Southern portion being completely shut in by mountains rising perhaps 3,000 feet above the level of the valley. The whole forms as beautiful a combination of plain, river and forest—covered mountains as can be seen anywhere. There are many charming camping grounds near the forests and just sufficiently far from villages for the traveller to be free from village dirt and annoyances, while at the same time, he is near enough to them to obtain readily such ordinary supplies as he may require. The one drawback is that the river which traverses the valley is of small capacity, being well filled only during the early part of the year; later on, in the autumn, the water dries up and the valley becomes very hot and somewhat unhealthy. On the flattened summit of the range which shuts in the valley to the S. E., is the well known Nagmarg, an open space surrounded by a forest of silver and spruce fir; this is a favourite resort for travellers who stay for weeks enjoying the lovely air and scenery. Nagmarg is just above the Wular lake, which lies to the S. E. immediately at the foot of the range. From the Lolab valley the lake is reached by a made road which ascends from near the village of Diur; the road is a very bad one, being merely, as is usual in such cases, an improvement of the existing *pagdandi*, though attempts have

been made from time to time to ease the gradients by constructing a new line of road. From the summit of the range, it descends at a fairly easy gradient to the village of Alosa on the borders of the Wular lake. In the lower parts, on this side, the road goes through a barren country and is consequently quite shadeless, so that whether going up or down, a start should be made very early in the morning to avoid the heat.

In former years, the Lolab was famous for its bear shooting, but the increase of sportsmen and frequent driving, have thinned them out so that they are now seldom to be seen except when driven down by snow. It has often been said that Kashmir is a country that could be colonised by Europeans and the Lolab Valley quoted as a place where they could settle, but no one can visit this region in August and September and hold to this opinion; the heat is so great that it is self-evident that no European could possibly work in the fields in the daytime; people are apt to forget that at 5,000 feet above the sea, on a plain like this, it can be exceedingly warm, so much so, that it is absurd to think of, say, retired Tommy Atkins ploughing in the sun. In fact there never was a more ridiculous idea than this Kashmir Colony scheme. In the first place there is no land available anywhere, and in the next it is far too hot and unhealthy in the Valley generally for Europeans to think of competing with natives in agricultural pursuits. Probably the only places where they could do out-door work in the Himalayas, are those at about 8,000 feet above the sea, but such places are unsuited to agriculture by reason of the altitude. One of the prettiest places in the Lolab for a camp, is the village of Andarbug and here we halted a couple of days, pitching our tents under some enormous walnut trees. It was still very hot in the day time but the evenings were charming and we enjoyed some rambles into the forest near, searching for ferns and curious walking sticks. The tour was now drawing to a close, as urgent business required a visit to Headquarters, so we up camp, and rising in the dark, got away on our ponies just as dawn was appearing and began the ascent from Diur village, to the Nagmarg ridge, and so on to the Wular lake. On the Lolab side, the road is very pretty, mounting through a deodar forest at first, and then the higher pines, while from the summit there is a great view of lake and distant mountains. The sun's rays were now beginning to be powerful, so after a brief halt, we pushed on down the hill to Alosa; this side, the road is very uninteresting running as it does through a bare country, and we did the right thing in starting so early, thus avoiding the heat: by so doing we had a pleasant march and reached the lake at a little after 9 a. m. Alosa is a rather pretty village on the shore of the lake, that is when the water is high, at present it has receded about a mile from the houses. In order to be near the boats, in which we were to embark for Srinagar, we went on to the ghat and camped there. This is a wretched collection of grass huts on a swampy

place and looked very malarious, the nasty looking nalas near being filled with rotting aquatic plants and the ground cracked in all directions by the heat of the sun. From the slopes above Alosa, which are sparsely covered with bushes of *Parrotia*, *Beaberis*, &c., comes a portion of the supply of hard wood (known as *janglu*) for Srinagar; the villager simply goes where he likes and cuts anything, bringing in so many *hatbas* or pieces above 1½ feet long, to Alosa, where the contractor buys them from him and sends them on to the City. The State gets a fourth share in kind levied at one of the taxing stations. Of course, under such a primitive system, the hill sides are almost entirely denuded of forest growth and other arrangements must be made for the future. We entered our boats the same night, so as to make a very early start and cross the Wular before the wind began to blow, making the passage dangerous for these flat bottomed craft. As our departure from the Lolab valley was a hurried one, we had to take our chance for boats, there being no time to obtain these from Sopar or Baramula; in consequence we could only get a very small one, so small that one of us had to sleep on the floor, but early in the morning we were able to change into a fine boat which had arrived from Duabgah and so we made our way back to Srinagar.

I have, during this trip seen the principal or at any rate, the most valuable forests in the Kashmir plain; there are others of great extent to be seen in the Lidar, Kuthar and Sindh valleys and towards Vernag and Gulmarg, but so far as can be ascertained, the forests of the Lolab are a long way the best deodar-producing tracts. Looking back on my tramp through these, my principal feeling is one of vain regret that they have not been under proper management during the last 30 years or more; they are of large extent, and from the reproduction to be found in many places and the general growth, it is evident that the soil is admirably suited to the growth of deodar. Had there been been no felling of young and immature trees, barking, hacking and destruction by fire, not only could the wants of the people have been supplied, but there would have been sufficient timber for a fine export trade with the plains.

Deodar has hitherto been used for work for which Kail would have sufficed, and it will now be a hard task to break though the custom. Nature has been so lavish that it is a thousand pities man should have done his little all to destroy her gifts, the wonder is that anything still remained, when it is considered that from time immemorial there has been practically no limit or check upon fellings. The only ray of light which pierces the gloom is the fact that the pure Kail forests are of great extent and have been comparatively little worked, also that there is much Kail intermixed with the deodar. By cutting out the former they will have more room, and in time the forests will contain this species alone. Every effort must be made to restrict the use

of the more valuable kind and to this end the price of the one must be raised and the other lowered if necessary for timber sold in Srinagar. But a disturbing factor is the enormous quantity of kail that is said to be required for firewood for the city; to a forester it is simply heart-breaking to see thousands of fine straight logs being taken there and split up for burning when they might be floated to the plains and sold for four times the price. This is a question which will be most carefully enquired into and every endeavour made to substitute something for the valuable timber which now goes to cook the Kashmiris, dinner. Another most difficult matter is the boatbuilding trade; hitherto boats have been built of the enormous *takhta* before described, but to the ordinary mind this is simply "unspeakable" as applied to the Turk! Not only is there a waste of timber, but trees do not now exist in sufficient quantities; there is nothing for it but a revolution in the art of boatbuilding. If these can be fashioned of huge size on the rivers in the plains, there is no reason why the like should not be done in Kashmir, but this will be declared impossible by the Kashmiri, especially when he sees Europeans who ought to know better using so-called planks, 75 feet long, to make a house boat. The natural consequence of this revolution will be extra cost in building, followed by an extra rent to be paid by the globe-trotter for his *donga*, and the cry will go up that the cheapness of living in Kashmir is a thing of the past. The Forest Department will be blamed for raising the price of timber, and it will be a wonder if they can get any one to understand that though as regards forests, Kashmir began with a fine large cake, so many slices have been cut off, that there now remains little more than the crumbs on the plate.—*Vale*.

J. C. Mc. D.

The Germination of Teak.

This large, deciduous, well-known tree is of the first importance in India, affording one of the best and most durable timbers known. It is light, easily worked and strong, and by being durable either in or out of water it has proved superior to every other timber for ship-building and countless other purposes. Much has been written on its habits and economic uses which might well, therefore, not find a place here; but there is one characteristic about its leaves which I may mention before proceeding to our legitimate subject—GERMINATION—for on it the structure and quality of the wood are said to depend.

My observations are limited, but I noticed that there are two distinct varieties of leaf. The upper side of the one is scabrous and the under side clothed with grey or tawny tomentum; but of the other, the upper side is glabrous and shining and the under

side covered with silvery scales. The former has not only a distinct rough feel, but is somewhat narrower, less ovate or obovate and gives off with greater ease a red dye when bruised between the fingers, than the latter.

From the structure of the leaf, as above described, the natives of Tinnevely and parts of the Coimbatore District, distinguish two varieties of Teak, and they prefer the one to the other for particular purposes. I have, however, found both varieties of leaf on the same tree: but the conditions or causes which produce these morphological differences in the structure of the leaves and, doubtless, through them in the physical property of the wood, must be worth studying.

GERMINATION.—The greatest obstacle to the spread of Teak is its slow and uncertain germination, added to the fact, that as the seed ripens and falls at the commencement of the hot season, a large proportion is destroyed by the annual fires; or is washed away into the ravines and streams by the monsoon torrents; or either rots, or is destroyed by vermin during the long interval that elapses between the fall of the seed and the rains which favour its germination.

Various attempts have been made to encourage and foster natural regeneration by self sown seed by the exclusion of cattle and fires; but such attempts, as the Annual Administration Reports show, have proved futile. We are, however, indebted to the late Dr. Roxburgh, at the instance of the much lamented Mr. Conolly, Collector of Malabar, to whom the splendid plantations at Nilambur owe their existence, for its artificial regeneration in nursery beds.

Artificial germination in nursery beds:—With some slight modifications Dr. Roxburgh's suggestions are still adhered to and they are, as carried out at Nilambur, as follows:—

The soil is dug to 12", reduced to a fine mould, levelled and partitioned into beds 32" wide within raised edgings 4" x 3" to retain the water. About the middle of April the seeds, after being immersed in water 48 hours or more, are spread over the beds and covered an inch thick with fine mould. Across the beds are placed branches on twigs of the wild gooseberry (*Phyllanthus Emblica*) which support a layer of straw, and the beds are daily profusely watered. The seeds germinate within eight or fifteen days when the twigs and straw are removed, the water gradually reduced until the monsoon has well set in and the plants, being then from 4" to 6" high, are put out into the area set apart for planting. A seed bed 32 inches by 50 yards will require 120 seers of seed and some 7,000 plants might be expected.

Notwithstanding all the care bestowed upon the seed in the nursery, a large quantity does not germinate. But the chief points learnt are:—

(i). That the seed must be ensured continuous moisture for its germination, which is best done by covering or burying it in the mineral soil.

(ii). Insurance of the seedling against drought.

Natural germination of self-sown seed :—The seed by being exposed on the surface does not receive that amount of continuous moisture essential for its germination. Then again when the seed is placed even in favourable circumstances its protracted germination causes the seedling to start life so late in the season that it is much too weak and insufficiently established to meet the increased transpiration and drought which immediately follows the monsoon. A great number of seedlings are also destroyed by insects which also make their appearance after the monsoon.

Natural germination may therefore be artificially assisted by breaking up and preparing the ground in parallel contour ridges round seedling Teak trees to a radius equal to the distance the top-most seeds are likely to fall. The surface is thereby kept wholesome and porous and the seeds which fall into the trenches are covered by the ridges being washed over them during the monsoon, and the porous prepared soil allows the taproot of the seedling to penetrate deep enough into it to insure the plant against drought and increased transpiration. In the majority of cases seedlings are found in places where the seeds are covered by a layer of sand or earth, or the ground broken up and worked into nodules by earthworms or similar agency.

The advantages that the method affords are :—

(i). The localization of Teak within its own habitat and associates, which must therefore tend to raise it to its maximum usefulness.

(ii). The removal of obnoxious weeds, grasses, and undergrowth which are fast supplanting the Teak and other useful trees, and which, notably the Lantana, are over-running the forests.

(iii). It costs very much less than a regular exposed plantation, and the seedlings are less subject to drought and increased transpiration during the hot season from shade afforded by the parent trees.

The financial difficulty, which this method involves, may be overcome by sowing in the area some of the better species of cotton or cereal grains, the crops of which might go to pay in part at least, the expenditure incurred. Or the ground may be prepared free of cost by allowing the jungle tribes to raise their crops on it. Then again, it is not unreasonable to suggest that a part of the forest revenue might well be spent in improving our forests and increasing their value and utility, for nothing can be got without labour and expense.

An experiment much on the lines advocated above was made by me last year on the Anamallais. The seeds on the trees around which the ground was prepared as previously suggested, were

unfortunately picked off for sowing in the nursery beds, other seed, were therefore sown broadcast over the area with, I am told splendid results.

In tracts, therefore, where the Teak has been over-cut, seed may be sown in parallel contour furrows and thus save the enormous expenditure incurred in clearing, felling and planting the area.

In the light of the foregoing, it seems to me that in Teak tracts cattle grazing, were it not for the fires that follow in its train by the carelessness of herdmen, must tend to help the germination of the seed, in that it crops the grass and treads the seed into the mineral soil, facts eloquently borne out in Tinnevely and other districts.

S. G. MOSS.

The Double Cocoanut of the Seychelles Islands.

The history of the Seychelles Cocoanut (*Lodoicea Sechellarum*, Labill.) is most curious. There is not a botanist who has not read about it over and over again, not a traveller to Madagascar, Réunion, or Mauritius, who has not viewed with astonishment its enormous, black, two-lobed fruit, a character that has given rise to names as strange as they are French. Ordinarily it is called "Coco de mer," because it is carried away by tidal currents and deposited on distant shores where it occasionally germinates and grows well; it is also called, "Maldive cocoanut" as it is found in those islands, transported thither undoubtedly by some current; "Solomon's cocoanut" "double cocoanut," are also names by which it is known, besides others; Rumphius mentions it in his *Herbarium Amboinense* as *Cocos maldivicus*, and alludes to the more or less fabulous stories about its supposed virtues—in one place it was used as an antidote to poison; in another, it was a wonderful specific against colic, apoplexy, paralysis, &c.

Without giving too much credence to the probability of these properties, it appears certain that the fruit of this palm tree fetched a high price. Travellers who were able to get it, paid £ 6 to £ 12 for a single fruit, while the largest specimens went for as high a figure as £ 18.

Precious vessels or cups were made out of the shell, and were used to hold tobacco, or betelnut. In the Maldives, the king made it a royal property, in order to present it to his favourites and the theft of one of these cocoanuts was a capital crime.

Vague ideas prevailed for a long time concerning the appearance of this tree in its native country, its size, leaves, stem, &c. But the discovery of the Seychelles islands in 1743 put an

end to these doubts. People soon found out that it was indigenous on the islands of Praslin, Curieuse and Ronde. Sonnerat described it botanically in his Voyage to New-Guinea, and brought it with him to Réunion. Commerson continued the observation and then Labillardière, who gave it its present name, and then Quean de Quincy, Governor of the Seychelles; but it was not until Messrs. Harrison and Telfair were enabled to send flowers and fruit preserved in spirits to Sir W. M. Hooker at Kew, that the complete botanical study of this curious plant could be undertaken.

The *Lodoicea* is found on the mountainous parts of the three islands mentioned above, where it grows on rocky soil in company with *Cocos nucifera*. Its majestic stem, 50 to 70 feet high as a rule, sometimes reaches twice this height, crowned with a magnificent head of leaves sixteen feet long and more. Travellers describe its appearance as noble, but somewhat melancholy. The young leaves while still undeveloped and rolled up at the top of the stem are edible, like those of the *Areca oleracea*; they are also pickled when fully grown, the broad handsome leaves frequently numbering more than a hundred on a single tree, are used in roofing, hat making, and even for thin walls. The midrib is made into brooms and baskets; the felt-like down which covers the young leaves is much valued for making pillows and mattresses.

The stem is made into pipes for irrigation, or furnishes building wood, or planks for boxes.

The fruit is not merely an object of superstition or curiosity; many useful and durable articles are made out of the nut, such as dishes, plates, bowls and cups. It is frequently used for storing drinking water, each shell holding about three quarts.

When ripe, one of these enormous nuts weighs as much as 40 lbs., and measures 50 inches round, and 15 inches long. At first it was thought that they ripened annually, but more recent observations have established the fact that they take many years, probably nine or ten, to ripen.

When the ripe fruit is subjected to a temperature resembling that of the Seychelles, it germinates readily and grows quickly. During the first few years, the young plant does not in the least resemble the adult tree; it is more like some of the *Pritchardias* of the Pacific.

As soon as the stem is fairly formed, its base is rounded, and fits into a natural bowl or socket, which is pierced by numerous small oval holes, with hollow tubes corresponding on the outside. The roots pass through these holes and tubes, and penetrate the ground, but they never become attached to the bowl, thus having a free play and allowing the tree to sway about in the wind, a very necessary provision against violent gales. The stem forms a splendid column, perfectly straight like an iron pillar, and covered with the old leaf scars. The leaves are covered with a

thick down before they unfold, and when fully expanded are fan shaped, ten feet long by five feet wide, though sometimes they attain a length of 20 feet and a breadth of 10.

The colour of the leaves is shining light green, and when they fade, they bend and hang downwards along the stem before falling. The crown of foliage generally contains twenty leaves, but this number may run up to a hundred according to certain travellers, and then the whole tree forms the most splendid object it is possible to behold.

The tree is dioecious. At the age of thirty years, it first puts forth its blossoms, the males forming enormous catkins three feet long and three inches in diameter, while the females are set on a strong zigzag stalk, covered with large reddish brown scales.

The fruit externally is covered with a thick fibrous husk, like the ordinary cocoanut. The inside, before the fruit is ripe, is formed of a kind of firm transparent jelly. Each fruit contains usually one, sometimes two or three, nuts with hard black shells, and divided at the top into two or more deep lobes.

The fruit of the *Lodoicea* has germinated more than once in hot houses. The first time was at Glasgow, but the young plant did not survive. Quite recently germination has been successful in the museum of Paris, and the young plants are doing well up to date; it remains to be seen how they will fare subsequently. It would be most interesting to be able to cultivate this remarkable palm in our colony.

(Extract translated from the 'Révue Agricole' of Mauritius) by A. S.

In putting before our readers the above translation of an article from a magazine which is by no means the least interesting of our exchanges, we wish to mention that it does not seem to be generally known what large numbers of these nuts must be brought to India. In travelling last year and this, in the neighbourhood of Hardwar and Rikhikesh, both great pilgrim places on the Ganges, we noticed that all the better class of the 'fakirs' who frequent the banks of the holy river and live on the offerings of the pilgrims, carried habitually with them a black curiously shaped bowl with a handle in which they drew from the river the moderate supply of water for their day's use. We made enquiries and at last through the kindness of a brother officer procured one of these bowls for the Forest School Museum. It proved to be the half of one of the nuts of the 'double cocoanut.' Judging by the numbers we have seen, the trade must be considerable and the numbers of the nuts brought to India for sale great, for we can hardly suppose that even all those we have seen were originally washed up by the sea on the coast of Ceylon or Malabar.

The only reference we can find in books to this use of the nuts is a very short one in Dr. Watt's Dictionary where it is also said that the nuts are procurable in Bombay, at Rs. 1 to Rs. 2 each. Seemann, in his 'Popular History of Palms' says, that the Chinese considered that water kept in the shell would preserve those who drank it from every complaint; but adds, by the East Indians as by 'Europeans' "it is probable that they are now only sought as a matter of curiosity or for domestic purposes." We hope some of our readers may be able to add some further information on this interesting subject.

HON. ED.

Cutch and its Adulterants.

Cutch and the method of making it is so well-known to all the readers of this Journal, that I do not intend to describe at any length the process of its manufacture, but will content myself with a very short description.

The heart wood of the cutch tree (*Acacia catechu* the *Shabin* of Burma and *Khair* of India) is cut up into small chips. These chips are first all boiled in water in earthen pots for about 12 hours, the solution is poured off and boiled again with fresh chips. After this process has been repeated several times the red solution thus obtained, is poured out into an iron cauldron which contains about 12 gallons. In this it is slowly boiled until the liquid assumes the consistency of a thick paste; that is to say it is boiled in the iron pan from 10 to 12 hours. The paste thus obtained, which has a brownish black colour, is then poured out into square or oblong moulds formed usually of leaves and allowed to cool. The resulting mass is the cutch of commerce. Good cutch should be brittle and break with a dark brown or black fracture. In addition to Burma, cutch is also extensively manufactured in Oudh and Kumaon.

The amount of cutch obtained daily varies very much according as the supply of cutch wood is plentiful and near, or far off and scarce. A yield of 15 viss daily from one cauldron would be very good, a yield of 9 viss bad, but I have known cases where as few as 7 viss daily was an average yield.

The price of cutch at the present time in the local market at Thayetmyo is :—

For hard cutch	Rs. 50	per 100 viss.
„ Soft „	35	„ „ „
„ adulterated cutch	16	„ „ „

As the license for 1 cauldron for the year (without a reserve) is only Rs. 20; in a good locality, an enormous profit must be made. As an example of what can be made where cutch is plentiful nothing further is needed, than to say, that in one of the Tharrawaddy reserves this year, the price paid for the license for the year amounted to Rs. 660 per caldron.

The uses of the Cutch prepared as above described are numerous; by the natives of India and Burma it is largely used for chewing with the betel leaf. It is also exported extensively to Europe and America where it is used for dyeing and tanning. Medicinally, it forms a powerful astringent which is largely used in fever and other maladies.

Having given the above imperfect description of the making and more important use of cutch, it might be of interest to refer to the results of Dr Warth's experiments made whilst on furlough in Europe during 1889-1890.

It had long been known that the makers of Kattah, as cutch is called in India, refused or were chary in using wood which contained no white spots in the heart wood. Externally they

could not tell whether the trees they were about to cut contained them or not. To determine this they cut into the trees, if the spots mentioned were not present, they left them unused, thus doing much damage to the forests.

A preliminary examination made in India, shewed that the trees with the white spots yielded more of the extract than those trees which had not got them.

The active principle of cutch is tannin. The tannin of catechu forms a greenish brown compound with ferric salts. Catechin as a rule is also present, in fact pure kattah is almost entirely catechin, and it is on account of the presence of this latter that it is chewed with the betel and lime.

Catechin is soluble in hot, but not in cold water, like tannin into which it can be easily changed. Tannin however cannot be changed into catechin. Owing to this property, the two principles can be separated, but even after long standing a little of the catechin remains.

From two specimens sent from Burma, Dr. Warth obtained but 6 per cent of catechin. From the wood of the same tree that this cutch was extracted from, Dr. Warth, by a rapid treatment with concentrated solutions, obtained a mean of 22 per cent of catechin in the extract. The two specimens from Oudh, one of which contained the white spots and one of which did not, gave a mean of 38 per cent in the extract.

From the above, Dr. Warth calculated the total yield of catechin in the wood to be as follows:—

Burma.	3½%	catechin from the wood.
Oudh.	7%	" "

F. J. BRANTHWAITE.

Obituary, A. F. Mein and W. E. D'Arcy.

We regret to have to record the deaths of these two officers, the one in England, the other in India. They both belonged to the same year and arrived in India in the beginning of 1876. Both served in Assam, Mein for his whole service, D'Arcy for a few years only, and both were known as excellent, hardworking officers.

D'Arcy was on the 49th *promotion* of Nancy students and one of his old comrades tells us that "he was the gayest and most 'social of his year and that it was always a great delight to hear 'him sing his quaint Irish songs.'" In India, too, he was always the best of company and had many friends. His chief service was in the Punjab where he has left a monument behind him in his Working Plans for Chamba and Changa-Manga. He was afterwards Assistant Inspector-General of Forests and then officiating Conservator in the Central Circle N.-W. Provinces.

Only shortly before his death, was published the work which had been a labour of love to him for several years, his "Note on the preparation of Forest Working Plans" which we strongly recommend to our readers.

Mein had passed the whole of his service in Assam, where the good work he did was well known. His death was caused by malarial fever contracted in the Assam Jungles.

II. CORRESPONDENCE.

A Departmental Blazer.

SIR,

I notice in the February number of the *Indian Forester* a proposal for the adoption of an Indian Forest School Blazer; like any suggestion which has for its object the assertion of the service and the formation of a close bond between its officers, I think it should receive every support from those interested. I enclose an advertisement of Messrs. Thacker and Co., Bombay, regarding a service crest for R. I. E. C. Officers, and in continuation of the Blazer scheme, I think it would be by no means a bad idea if an Indian Forest School crest was adopted. The letter I. F. S. in the form of a monogram, with a crown above and a suitable motto beneath, occurs to me as being the best design.

Z.

'Fires caused by Sparks.'

SIR,

As a little boy, it was one of my favourite amusements of a dark evening to strike together two pieces of flint and produce a "flash of fire." The larger the pieces of flint, that is to say, the more extended the surfaces of concussion, the larger was the flash. E. G. C. may any day try the experiment and convince himself, instead of puzzling himself with *à priori* reasoning and discrediting the evidence of the senses of others. He has no doubt seen glass at a red heat, and there is no reason why when two pieces of flint are violently struck together, the result may not be the scattering of a cloud of flint dust at a red heat. Given sufficiently large masses of flint and a sufficiently violent concussion, and there is no reason why an inflammable body in close contiguity may not take fire. Air cannot burn any more than flint can, yet, as everybody knows, when it is forced rapidly out of a tube with a piston, it acquires sufficient heat to set a piece of tinder on fire.

E. E. FERNANDEZ.

III. OFFICIAL PAPERS & INTELLIGENCE.

The Dehra Dun Forest School.

DISTRIBUTION OF PRIZES AND CERTIFICATES.

The distributions of certificates and prizes at this Institution came off on the 30th March, in the presence of several of the chief residents of Dehra and a number of officers of the Forest Department, who had assembled under the Presidency of the Inspector-General to conduct the examinations and deliberate on school matters. The large drawing hall of the school building was decorated with flowers, and the maps and plans drawn by the students, while in the museum and corridors were displayed the collections of plants and insects they had made.

The Inspector General of Forests, Mr. B. Ribbentrop, C. I. E., presided, and among the guests we noticed Major Begbie, 2nd Goorkhas, Mr. Leslie Rogers, Mr. McMinn, B. C. S., Revd. Mr. Reynolds and others, while the Forest Department was represented by Mr. Popert and Major Bingham, Conservators, Mr. W. H. Reynolds, Superintendent of Forest Surveys, Mr. Hearle and the School staff. Several ladies were also present.

The proceedings commenced with the reading of the report of the year by the Director, Mr. J. S. Gamble. After explaining how the last year had been one of change both in the staff of Professors and in the matter of the subjects taught, he referred briefly to the departure of the late Deputy Director, Mr. Fernandez, now engaged in reorganising the forests of the Baroda State, and the arrival of his successor, Mr. Smythies; and then expressed his acknowledgements to the school and circle staff for their help during the year. Mr. Gamble then explained how the number of students had reached a total of 75, while it was expected that another year would see nearly 100 at the school. Referring to the examinations, he complimented the successful students on their work and impressed upon them the necessity for keeping their eyes open in the forests and observing facts to illustrate the teaching they had gone through.

The performances of students in the Dehra Dún Mounted Rifles and the Athletic Sports were then alluded to. Trooper Martin's success in winning Captain Armstrong's cup at the Volunteer Sports, and F. A. Seager's good performance for the Inspector-General's prize in those of the school, were especially

mentioned. Reference was also made to the recently run five miles cross country race, for prizes presented by Mr. Eardley-Wilmot and Mr. Gamble, which were won by Daulat Ram and A. M. Walker, respectively. The list of medallists of the year was then read, the following being the recipients:—Forestry, Surveying, Forest Engineering and Botany, four medals, Amrita Lal Chatterjee; Forestry, Maung Charlie; Surveying, R. S. Bower; Herbarium, P. M. Healy; Zoology, R. C. Thompson: Lower Standard medal, Bhairon Pershad. The special prizes were won as follows:—Mr. Popert's prize for map drawing, C. W. B. Anderson; Mr. Eardley-Wilmot's prize for Entomology, R. C. Thompson; Major Bingham and Mr. Thurston's second prize for do., C. W. B. Anderson; Director's second Herbarium prize, G. V. Sarangpani; Mr. Moir's sylviculture prize, Jaimal Sing. The Director concluded his report by wishing success to passing-out students, and expressing the hope that they would continue to study Forestry and Natural History in their forest circles and not forget the teaching they had undergone at Dehra. The certificates were then presented by the Inspector General, who addressed the students as follows:—

“ I have once more the privilege of addressing the students assembled at the end of the school course. In a few days these lecture halls will stand deserted and some of the students now present, will have entered upon their official careers in the different provinces of the empire, whereas others will continue their studies in a grander and larger school-room—the forest—a School which is open to every one of us and where Nature does not cease teaching to all who are willing and able to learn. Our aim at the Dehra Forest School is to teach you to understand Nature and to fit you for her lessons; and everyone who has had the fortune of listening to the words of your Director must carry away with him the convictions that the means adopted towards this end are as practical as possible. Your museum contains a collection of wood specimens, an herbarium and other collections of natural products which under the Director's fostering care, have developed to such a degree of perfection that they now rival those of the first schools in Europe. Your lectures, conducted by officers specially selected amongst the Indian Forest Staff and other scientific departments, are always illustrated by practical examples, and far more than half the course takes place in the forest. If, under these circumstances, the results of the year's examinations (which, however, in my friend Mr. Popert's opinion, exhibit a great general practical improvement over those held during the last Dehra Forest Conference in 1886) have not come quite up to our expectations, some solid reason must be found to account for this. To some extent, no doubt, the shortcomings are due to changes which took place in the midst of the course both in the method of teaching and the teaching staff; but after making due allowances, I am inclined to believe that they are to,

an even greater extent, the consequence of an insufficient knowledge of mathematics when you entered the school; for the Director and the school officers assure me that, on the whole, you have not been wanting in industry. I sincerely trust that a gradual progress and improvement will take place, and I have received in this respect rather favourable reports regarding the junior class. I hope that my admitting this will act as an incentive to further exertion—for I warn you it lies in the nature of things that the demands made by the Board of Control will rise with the progress of time. As I have already pointed out, we demand more now than we expected five years ago and still are not quite satisfied. To those students who leave Dehra with a certificate in their pocket, I sincerely wish a happy and prosperous career, but I should be wanting in my solicitude for the school and perhaps more so for the service in general, if I kept silence on the question of future prospects, which might otherwise be misunderstood. Thanks to the latest reorganisation, there will, including Bombay, continually be 126 appointments in the Provincial service, ranging from Rs. 200 to Rs. 600, and these appointments will be open to passed students of Dehra and Poona only, but the fact must not be overlooked, that the main strength of the service, recruited from the schools of Forestry in India, must ever lie in the class of rangers. The principle which underlies the whole organisation of the Provincial services is that officers must work their way to the higher appointments through the grades of rangers, and consequently, in the near future, as qualified candidates for the higher posts become available, provincial patronage must give place to seniority and competitive merit in the practical working of the forests. In conclusion I may, however, inform you that a reorganisation of the ranger class is under contemplation, and that I anticipate considerable improvements in this respect."

The Director then called on the students to shew their appreciation of the visit of the Inspector-General, to which they responded by giving three hearty cheers and the proceedings closed with cheers for the Director, the Professors of the school, and the ladies.—(*Pioneer.*)

Forest products used in Soap making.

The North-West Soap Company, Limited, Meerut, has recently sent to the Reporter on Economic Products to the Government of India, for transmission to the Imperial Institute, London, the following specimens illustrating their manufactures:—

- (1) Soap prepared with 10 per cent. Eucalyptus oil from *E. Globulus* grown on the Nilgiris.

- (2) Soap prepared with 10 per cent. of Turpentine prepared at the Forest School Dehra Dún.
- (3) Mottled Soap made from tallow and cocoanut oil, and free from rosin.
- (4) Pale yellow bar Soap prepared with tallow, cocoanut oil, and rosin of American manufacture.
- (5) Household Soap prepared from tallow, and rosin manufactured at the Forest School, Dehra Dun.

The soap prepared with the Dehra-made rosin is reported as being darker in colour, but otherwise of nearly as good quality as that prepared with American rosin.

We are indebted to Mr. E. Thurston, the Reporter for the above. Hon. Ed.

The Forest Budget of 1892-93, extract from the Finance Minister's Statement.

FOREST.

The figures are—	Accounts, 1888-89. Rx.	Accounts, 1889-90. Rx.	Accounts, 1890-91. Rx.
Revenue	... 1,349,047	1,486,303	1,448,002
Expenditure	... 7,92,000	780,035	784,113
Net	... 557,047	706,268	663,889
	Budget Estimate, 1891-92. Rx.	Budget Revised, 1891-92. Rx.	Budget Estimate, 1892-93. Rx.
Revenue	... 1,511,100	1,497,800	1,567,200
Expenditure	... 905,700	879,800	970,500
Net	... 605,400	618,000	596,700

The financial results of Forest administration are expected to remain much the same as was estimated in March last. There has been a considerable increase of Revenue compared with the previous year, but the Expenditure has also increased. For next year a similar result is expected.

Budget estimates of the Forest Department for 1891-92.

It seems rather strange to receive these on the 30th April, 1892, just one month after the year to which they relate is at an end. It might have been interesting to have had those for 1892-93 which ought to be out by now and whose figures in totals we have already seen in the Finance Member's Statement. The various Resolutions contained in the Volume before us, bear dates between October 31st, 1890, (Andamans) and March 4th, 1891, (Bombay)—Madras is not included, why, we cannot say—but the Government of India Review is dated January 14th, 1892 and the Volume reached us April 30th, 1892. The figures speak for themselves. We need not refer in detail to the contents of this book, for in a very short time, we presume, the actuals for 1891-92, will be known, and the book become scarcely more than waste paper; all we need say is that the following are the latest figures of the estimates.

Revenue	Rs. 1,55,52,000
Expenditure	„ 92,55,000
			—————
Surplus	...	„	62,97,000
			—————

In 1889-90, the Surplus Revenue was about seventy-three lakhs, in 1890-91, sixty-six lakhs, and the falling off for 1891-92, is said to be due to the stagnation of the teak timber trade and the consequent fall of Revenue in Lower Burma.

IV. REVIEWS.

The Agricultural Bureau of S. Australia.

Agriculture in South Australia is apparently managed by a 'Bureau' or Board of ten Members with a Secretary. The Chairman is the Hon. W. F. Krichauff, well-known for the interest he takes in Forestry and all subjects allied to it. Branch Committees have been established at various important places in the Colony and a yearly Congress is held in Adelaide at which papers on Agriculture, Horticulture and Forestry are read, the list of such papers which we find in the Report for 1890-91 now before us, containing many whose titles look as if the articles were sure to possess considerable interest. Naturally, in the Report of a Board which concerns itself chiefly with Agriculture pure and simple, there is not much of interest to ourselves; but we note the large increase in late years of the area under vine-cultivation, which at the end of 1890 amounted to 9,570 acres with

an outturn of 762,76 gallons of wine. The Government, we see, proposes to obtain from Europe, as did recently with such success the Government of the Cape Colony, an expert wine cultivator, in order to try and improve the quality of the out-turn.

Olive-cultivation has also attracted the attention of the Bureau so that during the year under review, the outturn of oil was 6,838 gallons. The drying of figs has also been started, as well as the new system of desiccating fruit and vegetables.

Much of the time of the Bureau has been occupied by the discussion of the measures to be taken to combat the pests, both animal and vegetable, which are destructive to Agricultural plants. Against the Codlin moth (*Carpocapsa Pomonella*) so destructive to apple-trees, spraying with 'London purple,' 1 lb. to 150 gallons of water, has proved effectual ; while the destructive 'red-rust' of cereal crops has, so far, baffled all attempts to destroy it. A solution has, however, been discovered, which the Bureau recommends for the disinfection of almost any kind of plant. It consists in a mixture of 5 lbs. of whale-oil soap with four gallons of hot water. We can conclude our notice of the valuable work being done by this Colonial Bureau by regretting the failure of the Arbor day celebration, for such institutions are obviously most useful to a country by the interest they excite in trees and tree planting. And we may hope also that they often lead to a greater interest in Forestry.

The Madras Forest Administration Report for 1890-91.

Just as 1891-92, had come to a close, we have received this Report ; and, as usual with Madras Reports, find the expressions of policy given by the Board of Revenue and the Government more interesting than the records of useful work and the statistics of timber and produce sales. Almost the first paragraph of the Board's Review is one of the greatest interest, and we endorse most fully the Board's sentiments as regards the necessity for capital expenditure on the forests and their hints that possibly a large increase of revenue may sometimes be obtained at the expense of the growing stock. They say :—

“ *Establishment.*—The subjoined table shows the strength of the staff in the two circles :—

	Northern Circle.	Southern Circle.
' Conservators	1	1
' Deputy Conservators	4	8
' Assistant Conservators	8	7
' Sub-Assistant Conservators	6	8
' Rangers	24	33
' Foresters	50	77
' Forest Guards	359	396

‘ There was no change of any importance in the establishment during the year. Since its close, however, proposals for the increase and re-organization of both the superior and the subordinate establishments have been submitted to Government and have received the approval of the Government of India and the sanction of the Secretary of State. This new scale of establishment will be brought into force gradually in the two circles as qualified men become available ; and when the full complement is entertained, the result cannot but be most marked in the more efficient protection and development of the forests and the expansion of the revenue of the department. Even with the present limited resources at its disposal, the department has realized during the year under review a gross revenue of nearly 18 lakhs ; out of this, only some 12½ lakhs have been spent, leaving a surplus of 5½ lakhs, the highest on record, but it would be a mistake to consider the leaving of so large a surplus as this a matter for unalloyed satisfaction : in these early days of forest exploitation, the forests need all the money that can be spent upon them, and a surplus of nearly one-third of the total receipts is obviously much greater than it should be. For this starving of the forests, the present weakness of the staff must be held responsible, and with the full staff now sanctioned, therefore, this should be remedied, and a plentiful investment of capital in buildings, roads, demarcation, survey, &c., should be made.”

In a Province where Working Plans and their wholesome restrictions on over-zeal for a large Revenue hardly exist, such an expression of opinion is most important, for if the work of Forest Officers is chiefly to be gauged by the magnitude of the surplus revenue they produce, there may be a tendency to over-cut and to neglect that gradual improvement of the capital which is one of the first axioms of good Forestry.

The area of the Madras Forests, an area which, under recent orders, must all eventually become ‘ Reserved ’ is 17,823 square miles, so that the surplus Revenue comes to something over Rs. 30 per square mile.

Much space is devoted by the Board to the question of the progress of Forest Settlement, which we need not refer to except to say that, after all, in the important work of ascertaining the rights both of Government and of private persons over the forest lands, it is clearly better to be ‘ slow and sure ’ than to be in too great a hurry and possibly omit formalities or pass over claims which might give an infinity of legal trouble afterwards. We are glad to see that the Government of Madras has been pleased by the remarks of the Inspector-General of Forests, regarding their treatment of Forest Settlement, for they say in their Review :

“ When reviewing the forest administration reports of the various provinces for 1889-90, the Inspector-General of Forests

'declared that the treatment of these settlements as purely judicial proceedings was, in his opinion, unquestionably the intention and correct interpretation of the forest law, and was productive of the most stable and satisfactory results. In this view the Government concurs, and is glad to learn that the Inspector-General considers the Madras Forest Settlements to be the most perfect of any in India."

We quote the following remarks of the Madras Government on the question of opening Reserves to grazing in time of scarcity :—

"The results of the experiments ordered to be made to test the efficacy of the various methods of dealing with fodder reserves and pasture grounds will be awaited with interest. The development of the growth of good grasses and their systematic cultivation in the forests is a matter of the very highest importance, and the Government is inclined to agree with the Conservator, Southern Circle, in thinking that it is not always advisable to throw open the reserves to free grazing in seasons of drought. It is not incumbent upon Government to provide pasturage for an unlimited number of cattle. The agricultural cattle are recognised as possessing the first claim to consideration, and for them the reserves must if necessary be fully utilized; but a large number of the remaining animals are useless for any purpose except for manure, and curtailment of their numbers by judicious restrictions upon grazing is perhaps not subject for regret."

And we are glad to have seen from the Reports in the public Press that this policy has been adhered to, and has apparently been generally approved.

Turning to the reports themselves, the parts which are most likely to be of general interest to our readers are those which give information on the sylviculture of the chief forest trees. From the Southern Circle Report, we learn that 'Kongoo' (*Hopea Wightiana*) comes up best in Tinnevely after clear cuttings; that Teak seedlings will not appear where the ground is hard, so that digging or some similar operation is necessary for reproduction; that 'Benteak' (*Lagerströmia microcarpa*), Blackwood, 'Irul' (*Xylia dolabriformis*) and 'Vengai' (*Pterocarpus Marsupium*) all come up well in Malabar under protection from fire and cattle; and that generally, "It is not too much to assert that the more valuable timbers, e.g., teak, rosewood and 'vengai, were being exterminated in all accessible forest areas in the southern districts, first, from want of any protection, and later on by heavy fellings of all mature trees without any proper system or care for reproduction and insufficient protection." So too, in the Report of the Northern Circle we are told that in the Kistna forests, seedlings of 'Yepi' (*Hardwickia binata*), satiuwood and 'Chirimau' (*Anogeissus latifolia*) have come up so

well in protected Blocks as to shew the most marked contrast with adjoining ones which have not been so protected ; that Red Sanders in Cuddapah is in places coming up under protection to such an extent that “ it is difficult to penetrate through the ‘ mass of young poles of various species ’ ” ; that the growth of ‘ *Dolichandone crispa* ’ seedlings (we suspect this should rather be ‘ shoots ’) in some of poorer Reserves of Anantapur is satisfactory ; and that in the same District the additional protection of a stone wall to the Kottakota Reserve “ has caused a marvellous ‘ growth of trees of various species. ’ ” But the Board are mistaken in supposing the walls at Kottakota and Gootoor to have been built in the great famine, for it was the walls of the old Reserves in Cuddapah that were then built, those in Anantapur dating only from about 1885, we believe.

The information about artificial reproduction and experiment is rather confused, and the work would seem to have been rather too desultory to be business-like. But the season was about as bad a one as could be and a great amount of success was hardly to be looked for.

“ Inventions ”

Likely to ‘ take ’ and ‘ pay ’ in India and the East, is the title of a small Pamphlet of 32 pages which has just made its appearance in Calcutta and copy of which we have received. The author is a “ Solicitor and Pleader, High Court,” and he wants everyone to invent something, and in Part II, gives a variety of headings or subjects under which new methods are wanted. Among these we extract at haphazard the following:—easier modes for *pater* or *mater-familias* to ascend and descend from upper sleeping bunks of railway carriages ; a good gum that will stick fast ; good substitutes for quinine, marble and leather ; a smokeless powder ; flying machines ; unshrinkable flannel ; materials for paving our streets (why not try wood ?) ; better *ticca ghurries*, worked and lighted by electricity ; new ships, medicines and “ many other things too numerous to mention. ” We have put no notes of admiration—they can be supplied by the reader—and we will only remind the author of a well-known story:—“ You have heard that A has become bankrupt ? ” “ No, how is that ? ” “ Well you see he *invented* something. ” “ Oh ! that quite explains it ! ” While the rupee remains at such a low ebb, we are afraid that few out in India will be able to afford to invent anything.

A. S.

V. SHIKAR,

Destruction of a Rogue Elephant in the Dun.

The following is the account of the death of a Rogue Elephant which for some years haunted the neighbourhood of "*Parduni*" in the "*Motichoor*" Forests in the Eastern Dun.

Having taken out a licence to shoot the "Rogue" I went to *Parduni* on the 8th instant and took up my residence at the Forest Bungalow with the intention of staying there till I got a shot.

My men went out tracking each day, but it was not until the morning of the 12th, that they came across fresh tracks. One of the men ran back to camp to give me "*khobar*," and I at once started and joined the others at half past ten o'clock. The Elephant was then 70 or 80 yards in front of us, moving on slowly, knocking down Sal trees and pulling down Bamboos on his way. He went like this for two hours and stopped in a small thick patch of young Sal trees. We were about 50 yards from him and kept watching him quietly for half an hour when he lay down to sleep and began to snore, so that we all heard him. I climbed a tree close by and watched him with my glasses as he lay. He remained there fully 1½ hours and then got up and started again destroying the trees here and there on his way and eating their bark.

We followed him as before till 3 p. m., when he apparently made up his mind to go towards water and began to walk faster. With difficulty we kept up about a mile or more, over very rough country and through heavy jungle; but at last we missed him from our sight and lost his tracks also. All this time he never once entered or crossed a ravine, but kept on walking along the old "*Hathibahar*" (the Elephant road) on the ridges of the Sewaliks where it was impossible to get near enough to shoot. Next morning, the 13th, the trackers went out again but they failed to come across his fresh tracks and returned to camp unsuccessful.

On the morning of the 14th, they went out again and luckily found his fresh tracks. After a short time they heard him knocking down a tree, and sent the "*khobar*" to me in camp. I started at about 10 a. m. from the camp, to join the trackers and reached them in an hour, the place being 4 miles off.

When I joined them, I found that the "Tusker" was not more than one hundred yards from us, as we could distinctly hear him destroying the young trees. I sent one of the trackers named Mian Achroo Singh, the son of my old Shikari, Mian Tiloka Singh, to find out in what sort of place the Elephant was and how close I could get to him. Achroo was accompanied by a Forest Guard named Fateh Singh, who was the leader in the jungle, all the time we were after the Elephant, and who behaved all through very pluckily. They went about 50 yards and saw the Rogue standing under a patch of Sal seedlings eating the bark of a Sal tree which he knocked down while they watched. Achroo remained watching and the Forest Guard came back to give the information. I followed up to the spot accompanied by my Munshee, Ganga Parshad, carrying my second rifle. When we joined Achroo Singh, I saw that the animal was not standing in a good position for a shot, so we waited there under a "*Maljhan*" creeper, full $\frac{3}{4}$ of an hour before he moved on about 40 yards and stopped.

Achroo again followed, and before he had gone 20 yards from us he saw the beast, and silently beckoned to me to come up. I walked up to the spot very carefully and with my glasses distinctly saw the animal standing sideways about 35 yards from us. I left Achroo and Ganga there, and walked on carefully to a very small patch which was 25 yards from the *Tusker*, where I sat down and watched him with the glasses; Achroo and Ganga followed and sat down beside me with their rifles ready, as they were warned before hand. After 2 minutes, I brought up my rifle to my shoulder; aimed at him behind his ear and fired. The moment I pulled the trigger the brute threw back his ear, and the bullet passing through it, hit the exact spot at which I aimed and dropped him dead.

He was a fine animal 10 feet in height, 14 feet in girth, measured just behind his fore legs, and 25 $\frac{1}{2}$ feet from the tip of his trunk to the end of his tail; his foot prints were 20" x 17" and 5 feet in circumference, and his tusks were 27 inches out from his mouth.

The rifle with which I shot the *Rogue*, was a .500 bore magnum express by Alexander Henry of Edinburgh and London, burning 165 grains of powder, and carrying a hardened lead bullet with steel tip. The first day I was out, Mr. C. W. P., of Hardwar, was with me, and gave me the benefit of his great experience in tracking, but unfortunately he was laid up with a very bad attack of cold and could not leave camp the day the elephant was shot.

Camp Parduni, }
16th March, 1892. }

RUNBEER SINGH,
RAJAH.

A Tiger killed by Buffaloes.

A young Tiger that has for some time haunted the neighbourhood of Rampore Mandi on the Jamna in the Western Dún, and especially the buffalo grazing camp at Bagsain where that river passes through the Siwaliks, recently attacked one of the herd when the rest of them set upon him in a body and soon succeeded in killing him. The body was very badly mauled, the skin being in strips when it was found.

VI. EXTRACTS AND NOTES.

Growth of planted trees in Assam.

We have already referred (Vol. XVII, p. 463,) to the Assam Report for 1890-91, the text of which has now come to hand. The only point of any interest we can find is the record of the measurements of trees in the Kushi Plantations given in Appendix III.

The India-rubber (*Ficus elastica*) Plantation contains 88 acres in which are 2,417 living trees the largest of which date from 1873. Their average height is 53 feet and girth 4 feet. There are also some toon (*Cedrela* species, probably *microcarpa*) the dominant trees of which are 51 feet high with a girth of 16½ inches.

The Teak Plantations show the following measurements:—

Age. yrs.	Average girth.
19 42½ inches.
18 30½ "
17 36½ "
16 32 "
13 28 "
12 19½ "
10 20¼ "

In the Sissu Plantation 18 years old, the average height of dominant trees is 53 feet, and girth 23½ inches.

There is something unpractical about these measurements, which are on selected trees only, and consequently do not give true averages. We should like to see these Plantation measurements extended, so as to give the gradual yearly increase in amount of material.

We note that several species of bamboo are being planted and should be grateful if some Assam Officer would kindly describe the systems of planting, by seed, by offsets, &c., and the season at which planting is found to succeed best.

Aloe Fibre.

Under this term may be included the fibres obtained from a large number of plants most of which are of the same genus, and others of allied genera. Aloe, Yucca and Sisal hemp are some of the names by which these fibres are known in commerce. Though they are obtained from various species, they possess more or less similar characteristics. Among aloe-fibre-producing plants, the following are some of the best known:—

Agave americana (blue aloe), *Agave angustifolia* (aloe with small leaves), *Agave rigida*, *Agave Morrissi* and *Agave vivipara*. (Sisal hemp); *Furcraea gigantea* (Mauritius hemp) *Furcraea cubensis* (Silk grass).

The *Agave* is originally an American plant, but at the present day it is found naturalized in many parts of the world. In South Africa the different varieties of the plants have found a congenial home, and also in Mauritius. They are also found growing equally well in South Spain and India. The *Agave americana* (blue aloe) is the most common species found in all the above-named countries. The species has a long sword-like leaf, with parallel veins, eight to ten feet in length. The leaf terminates in a strong thorn. On account of this thorn the aloe has become a favourite one as a hedge plant, as it effectually checks the inroads of animals. In Sicily, Italy, and some parts of India many a plantation is guarded by an aloe fence. When the young suckers, which are both given off from the stem of the mother plant and produced on the long flower stalk, are put in the ground, they put forth a quick growth and become full-sized plants within three to four years of their planting. But the aloe does not flower so soon as it matures. It takes from eight to twenty years before producing the inflorescence which has a long pole-like stalk twelve to eighteen feet in length shooting out vertically from the plant, and this long flower stalk bears an immense number of branches, all of which produce flowers and at last young suckers. The fibre is found in the leaves of this plant and is very long and tough. The juice of the leaves is slightly acrid, but has a soapy character, and is sometimes used as a substitute for that substance in washing cloth, &c. The fibre obtained from this *Agave* has been long in use in Mexico in the manufacture of ropes and cordage, whilst in the West Indies, ropes, fishing nets and hammocks are made from it. *Agave angustifolia* is largely found in Mauritius and South Africa and resembles the *americana* in its habits and characters. *Agave rigida* and *Agave Morrissi* are almost allied to one another; the former is found abundantly in Yucatan, where its fibre is the chief article of commerce, whilst the latter variety is found in Jamaica and many of the West India Islands. The leaves of this plant are of a greyish green colour with sharp thorns set on the edges. It does not differ

much from the blue aloe in its habits and other characters. *Agave vivipara* is also known as the bastard aloe, the leaves are green but smaller in size when compared to the other aloes, being not more than three to four feet in length. It is found growing in South America where the natives hold its fibres in great esteem. Waterton, the well-known traveller of South America, says that it is of incalculable value to the natives, who always have a supply on hand. The strength of the fibre is really wonderful, and though so fine that it seems that it would snap at a touch, it is more like steel wire than a vegetable production. This plant also grows well in the north of Africa.

Furcraea gigantea and *Furcraea cubensis*—The genus *Furcraea* was not first included in the agave under the species *foetida*, but was subsequently separately classified as a distinct one. It is known as green aloe in Mauritius and was introduced from America, the home of the aloes. The stalk of this plant is sometimes very short and sometimes long. The leaves are numerous and erect, and are about eight feet in length and six to seven inches broad. There is a fair demand for aloe fibre in the European market, and it has been sold in London during the last few years at prices ranging from £30 to £40 per ton. The prices vary very much according to the qualities. Among the aloes, the "Sisal" stands the highest as regards quality and value, for a ton of Sisal fibre has brought on an average £53. The cultivation of the aloe is largely carried on in Yucatan and Mauritius, and the plant is gradually coming to the front as a commercial product in other tropical countries also. The Government of Jamaica is encouraging the establishment of aloe plantations, and in Ceylon some planters have joined together with a view to trying it on a large scale, and have applied for five thousand acres of Crown forest land for the purpose, which they are to be put in possession of without much delay. The formation of an aloe plantation is not attended with much difficulty. Any dry poor land will suit it, but rocky, gravelly soil is considered to be the best for the production of the finest fibres. In moist and rich lands the plants grow so vigorously that the fibre becomes poor in quality and smaller in proportion. It is also noteworthy that shade in any form is always prejudicial to the plant in all stages of its growth. It is always advisable to select vigorous specimens for the purpose of planting, and the young plants which grow around the stem are preferable for the purpose, to those which are produced in the flower stalks. The rainy season should be taken advantage of for planting purposes, not that a plantation would fail by planting in dry weather, but the plants would commence their growth well and begin to yield earlier. The number of plants which should be put down per acre differs greatly according to the practices of the planters. While the Mauritius planters consider 1,200 per acre a fair number, in Yucatan they put down only 600. In three to four years the

plants begin to yield. The leaves are then cut close to the stems, and are made into bundles and sent for the extraction of the fibres. There are various methods in use for the extraction of fibre from the aloe leaves. In Yucatan it is extracted by Death's fibre machines with a wheel of 50 inches in diameter, 8 inch-face and 8 knives or scrapers, and driven by a 10 H. P. engine; nearly 8,000 leaves being prepared in a day. In Mauritius the natives extract the fibre by striking gentle blows on the leaf with a piece of wood. In large plantations, machines of various sorts are used, the most favourite being the "Marabal" machine. The production per acre of fibre ranges from one to two tons, and on the whole those engaged in the aloe fibre industry are obtaining very satisfactory returns.—(*Indian Agriculturist*.)

Eucalyptus Oil.

The old saying, that "It is an ill wind that blows nobody good," is being realised by the dealers in Eucalyptus oil, which is strongly advocated as an influenza preventive [without however any adequate evidence of its being more than a palliative. *Ed.*] From our contemporary, the *Chemist and Druggist*, we learn that owing to the very great demand for the oil, a parcel of a fine brand which only two or three days previously had been sold for 2s. 6d. per lb., sprung up suddenly to 4s. 4d., since which time quotations have advanced by 6d. per day, or even more, till on January 20th it reached 7s. 6d., and on the following day 8s. was paid for the oil of *E. globulus*, and it was stated that 50 lb. of the same oil had been sold during the day at 12s. 6d. per lb. At that date, nearly all holders who had any merchantable oils to sell had been cleared out, but a vessel was said to be due having a considerable quantity on board, though most of this was already sold before it had actually arrived. Since this was written, the *Ormuz* has arrived with about 2,000 lb. on board, and further supplies are expected.

Our contemporary before referred to, speaking of the fillip which the influenza scare has given to Eucalyptus oil, says, it is highly probable that in the future it will remain a regular domestic remedy, as it has become in Australia, the home of the plants, which yield it; and it is further an interesting fact, that as the reputation of Eucalyptus oil has grown in public estimation, other sources of supply than Australia have been discovered, and even in Australia the distilling industry is no longer confined

to Victoria, all the colonies now sending supplies to this country. Considerable quantities of the oil are distilled in the South of France, and as many as 20,000 lbs. of the oil of *Eucalyptus globulus* are now exported yearly from California.

The growth of the *Eucalyptus* in California is another example of how rapidly new industries are developed in the far west. The first plantation of any extent was made in 1869, when 55 acres of hill land at the back of the town of Haywards, was planted with *E. globulus* seedlings, to supply the want of timber, and to improve the climatic conditions of the locality. As it proved a satisfactory investment, yielding a profit of 17.50 dols. per acre per annum, which was increased as experience was gained, the example thus set was quickly followed by others. One large forest was planted seven miles south of Los Angeles, and now the *Eucalyptus* is found over a tract of 400 miles along the Californian coast, cultivated in fields varying up to 100 acres. The trees, which are chiefly *E. globulus*, grow rapidly, and form a splendid shelter; the other species grown is *E. rostrata*, but this is cultivated chiefly for its timber.

At first no attention was given to the distillation of the oil, and its adoption as a commercial article is thus described:—"In 1883, a Mr. George Downie discovered by accident that a decoction of *Eucalyptus* leaves removed the scale from boilers. He set about putting a preparation on the market, and succeeded in this. Meanwhile, he found that in superintending the manufacture of the boiler fluid, he had lost an asthmatic affection from which he had suffered for years. A friend with whom he was associated in the work was also cured of bronchitis. They had noticed the pleasant odour which came from the boilers, but they were unaware that the leaves contained a volatile body until they were told what a valuable oil they were wasting. Means were at once taken to collect it, and that with the boiler fluid was the beginning of a very respectable industry, which was ultimately taken over by the company. The factory is situated at the San Lorenzo Station, on the Southern Pacific Railway. The trees in the forests and plantations are cut down, and the leaves gathered by men called strippers. From 10 to 12 tons of leaves are operated upon daily, these yielding 1,500 gallons of boiler fluid, and 70 lbs. of essential oil. The oil is thus a big product, and during past two years, it has become so important a part of the industry, that the company have appointed a skilful chemist, under whose instructions the purity of the distillate has become greatly improved." (*John R. Jackson, in the Gardener's Chronicle*).

The Teak Trade of the Laos States .

Mr. Ernest Satow, C. M. G., read a paper on Tuesday on the Laos States of Upper Siam, before the Foreign and Colonial Section at the Society of Arts, Adelphi Street. Sir Thomas Wade, K.C.B. G.C.M.G., presided, and in introducing Mr. Satow, her Majesty's Minister at Montevideo, said his chief claims to address them on the subject were that he had represented the British Government in Siam for four years, had been many years in the Consular and Diplomatic service in Japan, and was an eminent Chinese and Japanese scholar. Mr. Satow began his paper by stating that there were six Laos States in the north of Siam, in most of which British-Burmese subjects had for many years carried on an extensive trade in teak timber. In 1874 a treaty was negotiated by Siam and India in order to establish courts for trying law suits between owners and lessees of the teak forests in northern Laos. This treaty worked badly and was superseded, in 1883, by a fresh treaty concluded between Great Britain and Siam, under which a native Court was created at Chiengmai, the capital of the Laos States, for all cases, and a vice-consul was appointed to reside there and watch over the execution of its provisions and to protect the interests of her Majesty's subjects. But by the year 1885 there were great arrears of cases to be heard, and this having led to much dissatisfaction, Mr. Satow deemed it advisable to undertake a journey to Chiengmai to investigate the circumstances, and, at the same time, to make some inquiry concerning the teak trade of the States. This visit was the subject of the paper. After a journey of six weeks from Bangkok by steam launch on the river Me-nam, and by land from Utaradit, he reached Chiengmai, where he was hospitably received by the local chief and the Siamese Commissioner. The architecture of the principal buildings showed considerable artistic talent, especially in the direction of wood carving. With regard to the teak trade, he stated that many of the forests were worked by Asiatic British subjects, the usual terms being to take them on lease from the chiefs, paying a royalty of three or four rupees a log, besides a valuable premium. The lessees were seldom men of capital, but obtained funds at 3 per cent. a month from Indian money-lenders at Moulmein. The foresters, therefore, being mostly men of straw, frequently got into arrears with their royalties, and had to give promissory notes to the lessors. The result was that they got into difficulties, and disputes arose. The success of the forester depended entirely on the greatness of the annual rainfall. The logs were floated into the river Me-nam and brought down to Bangkok, where they were cut up at steam mills, and the wood then exported in sailing vessels to Europe. A discussion followed.—(*Timber Trades Journal*).

VII.—TIMBER AND PRODUCE TRADE.

Statement of average selling rates for timber and bamboos in Meerut, Cawnpore, Bulandshahr, Pilibhit, Bareilly, and Moradabad for the quarter ending 31st March, 1891

Description.	Timber Scantlings per score.		Bamboos per 100 score.		REMARKS.
	From	To	From	To	
MEERUT.					
Sal 10' Tors (Poles) ...	R. A. P.	R. A. P.	R. A. P.	P. R. A.	
Sal 10' Tors (Poles) ...	10 0 0	20 0 0	
Sal Karris, 12' x 5' x 4" ...	25 0 0	40 0 0	
Sal bed posts, 7' x 2½' x 2½' ...	7 8 0	1,210 0 0	
Bamboos of 9' to 10', per 100 score	25 0 0	80 0 0	
CAWNPORE.					
Sal 10' Tors (Poles) ...	2 8 0	3 0 0	
Sal, Sain Karris, 12' x 5' x 4" ...	10 0 0	12 0 0	
Sal bed posts, 7' x 2½' x 2½' ...	2 0 0	2 8 0	
Bamboos of 9' to 10', per 100 score	20 0 0	35 0 0	
BULANDSHAHR.					
Sal 10' Tors (Poles)	
Sal, Sain &c., Karris, 12' x 5' x 4"	
Sal bed posts, 7' x 2½' x 2½'	
Bamboos of 9' to 10', per 100 score	50 0 0	50 0 0	
PILIBHIT.					
Sal 10' Tors (Poles) ...	40 0 0	70 0 0	
Sal Karris 12' x 5' x 4" ...	30 0 0	40 0 0	
Sal bed posts 7' x 2½' x 2½' ...	5 0 0	6 4 0	
Bamboos of 9' to 10', per 100 score	60 0 0	100 0 0	
BAREILLY.					
Sal 10' Tors (Poles) ...	5 0 0	10 0 0	
Sal Karris, 12' x 5' x 4" ...	50 0 0	60 0 0	
Sal bed posts, 7' x 2½' x 2½' ...	25 0 0	35 0 0	
Sal bed posts, 7' x 2½' x 2½' ...	10 0 0	40 0 0	
Bamboos of 9' to 10', per 100 score	15 0 0	
Bamboos of 9' to 10', per 100 score	50 0 0	137 8 0	
MORADABA D.					
Sal 10' Tors (Poles) ...	20 0 0	22 0 0	
Sal, Sain, &c., Karris, 12' x 5' x 4" ...	30 0 0	60 0 0	
Sal bed posts, 7' x 2½' x 2½' ...	10 0 0	12 8 0	
Bamboos of 9' to 10', per 100 score	50 0 0	100 0 0	

VOL. XVIII]

[No. 6.

THE
INDIAN FORESTER ;
A MONTHLY MAGAZINE
OF
FORESTRY,
AGRICULTURE, SHIKAR & TRAVEL.

EDITED BY

J. S. GAMBLE, M.A., F. L. S.,

CONSERVATOR OF FORESTS, AND DIRECTOR OF THE
FOREST SCHOOL, DEHRA DUN.

JUNE, 1892.

MUSSOORIE :

PRINTED AT THE MAFASILITE PRINTING WORKS
COMPANY, " LIMITED."

1892.

Contents.

No. 6—JUNE, 1892.

	Page.
I.—ORIGINAL ARTICLES AND TRANSLATIONS.—	
<i>The Forests of Natal; being an account of the Report on them by H. G. Fourcade of the Cape Forest Service, by D. E. Hutchins</i> ...	205
<i>Timber carting in Surrey, by A. W. Lushington</i> ...	214
<i>Cutch and its Adulterants, No. 2. by F. J. Branthwaite</i> ...	217
<i>Rate of growth of teak in the Magayee Plantations, Burma, by J. N.</i> ...	218
<i>A note on the Californian Poison oak. Translated by S. E-W.</i> ...	222
II.—CORRESPONDENCE.—	
<i>The Warrant of Precedence, letter from "D. F. O."</i>	225
<i>The Formation of Dew, letter from E. E. Fernandez</i> ...	226
<i>A plea for our feathered friends, letter from Tau Tha</i> ...	227
<i>A Departmental Blazer, letter from 'T'</i> ...	229
IV.—REVIEWS.	
<i>Administration Report on the Railways in India, for 1890-91</i> ...	230
<i>Raising Strawberries from seed, by A. S.</i> ...	232
<i>The Berar Forest Report of 1890-91</i> ...	232
V.—SHIKAR.—	
<i>A Man-eater, by E. D.</i> ...	234
VI.—EXTRACTS AND NOTES.—	
<i>The comparative value of various fuels</i> ...	236
<i>The pencil cedar industry</i> ...	238
<i>Creosoting sleepers</i> ...	239
<i>Is it good to dig about trees?</i> ...	240
<i>Olive oil in the South of France</i> ...	241
<i>Forestry Lectures in Edinburgh University—Session 1891-92.</i> ...	243
<i>Seeding of Bamboos</i> ...	244
VII.—TIMBER AND PRODUCE TRADE.—	
<i>Churchill and Sim's Circular of May, 1892</i> ...	245
VIII.—EXTRACTS FROM OFFICIAL GAZETTES.—	

THE
INDIAN FORESTER.

Vol. XVIII.]

June, 1892.

[No. 6.

The Forests of Natal,

*Being an account of the Report on them, by Mr. H. G. Fourcade
of the Cape Forest Service, by D. E. Hutchins.*

Part 1.

It is almost a trite saying that Imperial Rule in South Africa has, with rare exceptions, been a series of blunders. Its tendency has been negrophilist and anticolonial. Anthony Trollope summed up in two words, "Exeter Hall," the root of all the English mistakes in South Africa. Nowhere has Exeter Hall influence had more disastrous results than when, in former British Kaffraria, and in Natal, it planted Mission Stations and native locations, on forest lands. Many a square mile of the beautiful evergreen forest of South Africa has been laid waste as a consequence of this policy. Imperial rule is responsible also for most of the forest alienation in South Africa. With responsible Government at the Cape, came a care of the forest that, in forest matters, has placed Cape Colony quite in the van of British Colonies. The Crown Colony of Natal on the eve of responsible Government, has, in its forest, to take over a sad legacy of misrule. Three fourths of the forests have been alienated and the remainder—about 55 square miles—is a wreck, described in graphic terms in Mr. Fourcade's report. The Natal Forests of the present day are about one tenth of the area of the Cape forests. In 1880, a Forest Commission was appointed. Its report brought together much valuable information and it was decided to close the forests throughout Natal entirely. But this drastic measure did not have the desired effect. Supervisors, usually farmers or other local residents, were appointed on small stipends, to check stealing. Their efforts were but partially successful. At last, in 1888, application was made to the Cape Government for the loan of a professional Forest Officer to inspect and report on the forests of Natal. Mr. H. G. Fourcade, an assistant in the Knysna

Conservancy, was selected for the purpose and his report, a blue book of just under 200 pages, is the result. This report, able as it is, was not the only result. The Natal Legislature has just passed the second reading of an excellent Forest Act; and Herr Schöpflin, the German Forest Officer selected for the appointment of Conservator, has proceeded to Natal and taken up his duties there; Mr. Fourcade considering his position in the Cape service better than the terms offered by the Natal Government. It was my good fortune to travel through the forests of Southern Germany last summer with Sir D. Brandis, Herr Schöpflin and the Cooper's Hill students. I shall not be alone in congratulating Natal on the choice of its first Conservator. The New Natal Forest Act is, in the majority of its sections, a textual copy of the Cape Forests Act of 1888. But the Natal Act goes further than the Cape Act in the powers granted to the Conservator; and certain omissions in the Cape Act, such as the inalienability of demarcated forest, are supplied in the Natal Act. The matter in Mr. Fourcade's report falls under two heads (1) General Forestry (2) Description of the forests of Natal. The latter, the first of its kind that has seen the light, cannot fail to interest readers of the *Indian Forester*.

"The forests of Natal may be divided, with reference to their nature and distribution, into High Timber Forests, Thorn Bush, and Coast Forests, found respectively in the Upland, the Midland, and the Coast regions. The High Timber Forests are situated in the belt along the Drakensberg, forming patches mostly on south slopes, at an elevation of from 3,500 to 6,000 feet, where the mean yearly temperature ranges from 52 degrees to 59 degrees Fah. The upright yellow-wood, *Podocarpus Thunbergii*, reaches its greatest development in this zone, but occurs mixed with numerous other species. The Thorn Bush consists chiefly of various species of *Mimoseæ*, *Acacia Natalitia* and *A. Kraussiana* being the most common. It is spread over very wide areas, mostly in the basins of the Tugela and of the Umkomanzi, at an altitude of from 3,500 to 1,000 feet, below which it intermingles with the coast forest. In this region, the mean annual temperature ranges from 59 degrees to 67 degrees Fah. The Coast Forest predominates below 1,000 feet where the climate becomes sub-tropical, and the mean annual temperature ranges from 67 degrees to 71 degrees. It is composed of a great variety of low trees, among which the Waterboom *Eugenia cordata* and the Flaterown *Albizzia fastigiata* are characteristic species."

Taking away the subtropical belt, and adding altitude for loss of latitude, the distribution of the High-Timber forest and of the Scrub Forest, in Natal, is the same as that in the East of Cape Colony. The High-Timber forest of Natal is almost identical with that of the east of Cape Colony. There is rather more difference—a difference of a few species only—between the eastern forests and

the Southern or Knysna forests of Cape Colony. Between these three great geographical groups of forest in South Africa, there is a curious regularity of distribution. Broadly speaking, the Knysna forest extends from sea level to an attitude of 2,000 feet; the Eastern forests from 2,000 feet to 4,000 feet; the Natal forests from 4,000 feet to 6,000 feet. The Polela forests are the best of the High Timber forests of Natal and this is Mr. Fourcade's description of them.

"The largest timber forests of Natal are situated in the South-Western portion of the colony, towards the Transkeian border. In the division of Polela, there are about 10,000 acres of forest on crown lands and some 5,000 more on native locations which still contain large quantities of valuable timber.

The Xumeni forest was the first examined. It is bounded to the south by the Dumadezwa location, occupied by the Memela tribe, and covers about 1,200 acres of south and south-westerly slopes, at an altitude of 4,000 to 4,500 feet. The climate is temperate, frosts are prevalent in winter and thunderstorms in summer. The soil is light, moist, and consists largely of humus. The underlying rock (Maritzburg shale) protrudes in many places and detached boulders are scattered over the surface. The prevailing species is the Upright Yellowwood *Podocarpus Thunbergii*, which alone constitutes the greater portion of the standing stock. Other trees are the Natal Mahogany *Kiggelaria Dregeana*, the stinkwood *Ocotea bullata*, the Wild Chestnut *Calodendron capense*, the Saffron *Elæodendron croceum*, the Camdeboo stinkwood *Celtis Kraussiana*, and the Onderbosch *Cryptocarya sp.* The surface growth, composed of nettles and ferns, does not contain many young plants of valuable species. On entering the forest, the great scarcity of saplings is at once apparent; large quantities have been taken by the Kafirs of the adjoining location for wattles to build their huts with or as kraalwood or firewood. In the upper portion of the forest, a steep declivity has been denuded of undergrowth to such an extent that the soil has been washed away round the large trees which now seem to grow out of a sheet of rock, and if these trees were now felled, that portion of the forest which they occupy would disappear entirely! The quantity of mature timber that has been taken from the forest cannot be considerable, as there is still an abundant supply of Upright Yellowwood of large dimensions, averaging nearly 3 feet in diameter, and much Stinkwood and Natal Mahogany of fair quality. Sneezewood is scarce. Though the slopes which the forest covers are generally steep, it appears that most of the timber could be extracted. There is very little spare Crown Land in the vicinity, a circumstance that would render the working of the forest difficult. The forest is accessible from the main road to Polela, and produce could be transported easily. The ruling rates to Richmond are 30 to 40 shillings for loads of 800 running feet. Yellowwood was formerly delivered at the sawpits for 2½

' or £4-10 a load, when the license was one pound a saw per month. For sawing Kafirs are paid 12 to 15 shillings a load, cut into scantlings or planks. Hard woods are cut at the same rates, but the load is reduced to 600 feet. Natives for felling receive 10 to 15 shillings a month, and food worth 7 to 8 shillings. The native locations in the neighbourhood could supply a large amount of cheap labour. The edge of the forest is very broken; mealie (maize) gardens extend from the Dumadewza location all along the forest line, and some of the clearings have even been made right into the heart of the forest. Thousands of head of cattle are said to be regularly driven each winter into the forest for shelter, causing much damage to the undergrowth.

' The Mahutzwa Forest is situated a mile west of Polela, just outside the location No. 2, Upper Umkomanzi. Its extent is about 800 acres and the mean altitude 4,500 feet. It covers the northern side of a valley intersected by minor kloofs. With the exception of a main ridge and of a flat terrace near the river at the bottom, the ground is too steep for convenient working. The soil is light and deep, but stony in the steep places. Marizburg shale forms the underlying rock. The forest has been partially worked and there are no trees of great size. The principal species are the Outeniqua and Upright Yellowwoods, the Camdeboo Stinkwood, the Sneezewood, the Wild Chestnut, the Natal Mahogany, the White Ironwood *Toddalia lanceolata*, the White Pear *Apodytes dimidiata*, *Euclea lanceolata*, *Plectronia* spp., *Kraussia lanceolata*, *Royena lucida*, *Gardenia Rothmannia*, *Olea verrucosa*, *Elæodendron* spp., *Celastrus* spp., *Dombeya rotundifolia*, *D. natalensis*, *Crypocarya* spp., *Halleria lucida*, *Schmidelia africana*, with some smaller species such as *Myaris inæqualis*, *Cluytia* spp., *Heteromorpha arborescens*, *Leucosidea sericea*, &c.

' A sample area, selected to represent the average of the forest, was found to cover 2.92 acres. 59 trees measured within it were estimated to contain 3,842 cubic feet of sound logwood, and the standing stock per acre consisted of:—

6	Outeniqua Yellowwoods	...	603	cubic feet.
7	Camdeboo Stinkwoods	...	426	"
2	Sneezewoods	...	114	"
2	Wild Chestnuts	...	105	"
2	Natal Mahoganys	...	41	"
2	Other Woods	..	81	"

' Total 21 trees 1,370

' This yield per acre compares favourably with that of the best Cape forests, but it is greatly exceeded in other parts of the Polela district.

' The Mahutzwa forest is being destroyed rapidly by the natives. The young growth has already been entirely cleared for wattles. Troops of native women appear to be constantly cutting

and removing timber for firewood without let or hindrance. The firewood is made up into bundles and carried to the adjoining location, the path to which should be closed if the forest is to be preserved. At the foot of the forest, mealie gardens eat into the boundary everywhere, and all the forest ground that is not too steep is gradually cleared for cultivation. Inside the forest, natives fell large trees for firewood by burning round the roots, and the fire usually spreads some distance round if the bush is dry. Grass fires have caused much damage in the western end of the forest.

There are two forests towards the Polela River, with an area estimated at 1,750 acres in which sawing was formerly carried out nearer to the Umkomaas, and there is also a patch of forest about 500 acres in area, covering south-eastern slopes in the kloof below Colvill's Hill, and surrounded by mealie gardens wherever cultivation is practicable. These forests resemble the Mahutzwa, excepting that stinkwood is now found in some abundance, probably owing to the greater elevation (5,000 to 5,500 feet.)

Forests beyond Dronk Vlei.—Returning towards the coast, several forests are met with in the valley of the Umzimkulu, The Hlabeni Forest is situated about two miles east of the river, between the farm "Dudwick" and Location No. 1, Upper Umkomanzi. A flat-topped hill is crowned by rocky cliffs, from the foot of which the forest spreads downwards on south slopes, generally steep, and in some places almost inaccessible. The area is about 15,000 acres, and the mean altitude 4,500 feet. The chief timber trees are the Upright and Outeniqua Yellowwoods, Stinkwood, Bogabog *Xylosma menospora* and Sneezewood *Pteroxylon utile*. Here, as almost everywhere else in Natal, the absence of young stock is striking. The best timber has been cut out, and the forest so damaged in other respects that it will probably be found best to close it for a number of years. The country between the Gwangwane River, which forms the boundary of Griqualand East, and the Umzimkulu River is richly wooded. The Gwangwane Forest, situated on Crown Land, is the largest and most important in this region. It is a truly magnificent forest; indeed, for its size, the finest that I have yet seen in South Africa, and the nearest approach to a *pure forest of yellowwood*. The trees well grown and regular, average between three and four feet in diameter and a hundred in height, and consist chiefly of Upright Yellowwood, mixed with a few Outeniqua Yellowwoods, Stinkwoods, Wild Chestnuts, and White Ironwood. In the lower portion, the standing stock per acre may be estimated at 10,000 cubic feet, consisting of 25 Yellowwoods, containing 9,000 cubic feet, and 8 other trees containing 1,000 cubic feet. An excellent feature is the presence of a young growth of yellowwood, partly in the pole stage. At present, the forest is only reached by a road from Griqualand East, and the quantity of timber felled in it has been small. The destruction of young trees by natives has also

' been slight, but the forests nearer Dronk Vlei being now almost cleared of wattles and poles, it will increase rapidly if it is not checked. There are few natives near the forest, and in consequence, few mealie gardens along the edge.

' Between Location No. 1 and Location No. 3 to the south, the Umkayini Forest, about 1,200 acres in area, has been reserved. The hillside which it covers overlooks the Gwangwane River and slopes rapidly with a south-western aspect; altitude, 4,500 feet. The forest was poor at the best of times; and as it has been worked considerably, there remains very little timber of value. Both of the Yellow-woods, Sneezewood, Natal Mahogany, and Zwartbast are still found, but the trees are inferior and scarce. At the time of my visit, quantities of poles and spars were being cut for the Trappist Missionaries at Dronk Vlei—it was stated by permission of the Government—and removed along a large slip path penetrating far into the forest."

The description of the vegetation in these forests would apply with one exception to that of the forests in the east of Cape Colony. In fact, the forest in the fertile south-east corner of the continent of Africa runs along the mountains with but little change, from the Amatola Forest country, the classical ground of the Kafir wars, through the semi-civilized Transkeian territory to the Colony of Natal. The Alfred forests of Natal differ in no respect from the mountain forests of the Transkei. Mr. Fourcade describes the Alfred forests thus:—

" *Forests in Alfred County.*—The Forests in Alfred County are, next to those at Polela, the most valuable in Natal. The Ingeli Forest extends for five miles along the south-eastern slopes of a spur of the Zuurberg range, the top of which forms the boundary of Griqualand East. Its area may be estimated at 3,500 acres. Portions of the forest have been cut off and included in adjoining farms: Mr. Quicke's on the eastern side, and Mr. Clark's on the western. From the foot of the forest, the ground stretches to the south in undulating plains, watered by numerous streams issuing from the forest; but as this land has been alienated almost to the edge of the forest, the latter is now hemmed in between private farms; and future working will have to be carried on under difficulties. The forest is steep in the upper portions and in some of the kloofs that take their rise there.

' Here and there the vegetation has become stunted, and the ground poor, on account of former injudicious working. The principal timber trees are: Upright and Outeniqua Yellowwood, Stinkwood, Sneezewood, Camdeboo Stinkwood, Bogabog, Natal Mahogany, Assagai, Essenhout *Ekebergia Capensis*, *Popowia Caffra*, *Olea verrucosa*, *Mimusops obovata*, *Toddalia lanceolata*, *Gardenia Rothmannia*, *Kraussia lanceolata*, *Clerodendron glabrum*, *Royena lucida*, and *Zanthoxylon Capense*. Smaller trees are *Halleria lucida*, *Cryptocarya* spp., *Plectronia ventosa* *Strychnos* sp., and *Burchellia Capensis*.

'The Ingeli must have once been a magnificent forest, perhaps equalling the Gwangwane in richness. It is deplorable to see how ignorant and ruthless working has contrived to ruin a large portion of it. The quantity of timber formerly obtained, large as it was, and probably greatly exceeding that for which the Government received any consideration, does not give a measure of the destruction effected. Irregular working is essentially wasteful, and it has proved the curse of many South African forests; a result by no means surprising if we realise the nature of the process. The woodcutter of old used to roam through the forest to choose a tree, and damaged many or even felled a few before he could find one to suit his convenience. The tree selected was felled high and crowned low, the finest marketable piece of timber being taken, and the rest, often amounting to more, left to rot in the forest. Then, to make a sawpit, the straightest trees, in the most promising stage of growth, that could be found sufficiently near, were felled and dragged together. More destruction followed, after the log had been sawn: a forked tree was selected; the forked branches cut out to make a sledge, and the trunk abandoned. A slip path was next required to remove the sawn wood, piled on the sledge, to the nearest main path, and to make it broad enough for a span of oxen, many young trees had to be cut. When slipping the wood down steep places, a young tree was tied behind the sledge, its crown of foliage acting as a brake, and for every steep portion of the path the process had to be repeated. Other young trees were also cut along the path and thrown across to facilitate the slipping. When the main paths became cut up or muddy, deviations involving the clearing of more young trees were freely made. Sometimes, as in the Ingeli, the main paths were made wide enough to take ox-waggons into the centre of the forest. The finest trees were gradually cut out whenever they could be easily extracted, and the kloofs and other steep places remained almost untouched. In those portions that were worked, the young growth was continually destroyed or damaged. Kafirs, by cutting wattles and other small wood, and cattle by browsing, helped to prevent it from making any headway, so that it has now completely disappeared in some places, leaving inferior old trees, the refuse of former woodcutters, to cover the crop of rubbish on the ground. A considerable quantity of timber has been left in the less accessible places, and much of it could be worked without endangering sensibly the chances of recovery of the forest. At present, there is very little work carried on. Since 1883, when the Natal Forests were closed, it has consisted chiefly of the removal of old logs that had been left by former woodcutters, but now that felling is resumed under Proclamation No. 24 of 1888, wagonwood is taken in increasing quantities. The main road from Harding to Kokstad passes close to the eastern end of the forest, and it would not be difficult to improve the branch road that skirts the foot.

' The "Stinkwood" bush is a patch of forest within a mile to the south, formerly rich in wagonwood and stinkwood, as its name implies, but now considered "cut out."

' A fine forest, known as the Impetzne, is situated about five or six miles further south. Crown land still surrounds it on every side, but farms are being rapidly taken up, and no time should be lost in reserving enough land for convenient working. The area is about 1,800 acres, the mean altitude 5,000 feet, and the aspect south. Much of the forest clothes the sides of steep gorges at the head of the basin of the Umtamvuna River; its shape is irregular. The configuration of the ground affords shelter from easterly gales. As only a few loads of timber have been cut, the forest is still very rich in upright yellow-wood and stinkwood. In a sample area 1.43 acres in extent, 58 trees, containing 11,423 cubic feet of log-wood, were measured. The growth was fairly average, excepting in the case of stinkwood, many logs of which had been cut in the vicinity, so that about double the estimated yield of this species would more nearly represent the average for the whole forest. The standing stock per acre deduced from the measurement was:—

26	Upright yellow-wood	...	6,186	cubic feet.
5	Stinkwood	...	560	"
3	Bogabog	...	153	"
2	other species	...	109	"
<hr/>				
Total ...	36 trees, containing	...	7,008	"

The principal kinds of timber found in the Impetzne forest are, in addition to upright, stinkwood and Bogabog, which comprise over 90 per cent. of the standing stock, sneezewood, saffron, hard pear, ironwood and Beukenhout. I did not see a single specimen of the Outeniqua yellow-wood. The extraction of the timber is difficult over the greater portion of the forest, and the produce has to be removed over several miles of broken country before it can reach the nearest wagou-road, but using steep gradients, a forest road might be made at a reasonable cost. There are no natives located or squatting in the immediate neighbourhood, and wattle cutting has been moderate. I am, however, informed that large troops of cattle are driven into the forest in winter; the damage which they cause is very apparent in the upper portions.

Both the Ingeli and the Impetzne forests are placed under the supervision of Mr. J. Furniss, who is paid £24 per annum for his services. Mr. Furniss deserves praise for his efforts to stem their destruction by natives; he has succeeded in getting rid of the mealie gardens which are so obnoxious a feature elsewhere, and there is no reason to believe that their eradication throughout the Natal forests would be a matter of any great difficulty."

The figures obtained from the sample area in the Impetzne forest merit special attention. We cannot however compare

these directly with the figures quoted from the Knysna forests. These latter represent no more than the exploitable timber from nearly equal annual areas cut over on a 40 years' rotation of conversion. Little or none of this forest is quite virgin forest: the greater portion has been more or less irregularly cut over for the last half century.

The following paragraph describes a condition of the forests with which I became only too familiar while demarcating the Eastern forests in Cape Colony:—'The wooded area in the Zwaartkop location was estimated at 8,000 acres in 1880. Little remains of what must have once been a noble forest. Clumps and isolated trees scattered over an area much larger than that actually wooded, remain to testify the destruction that has been wrought of late years. The forest has been attacked from every side but the top, where it follows the steep crests of the hills. Below, the edge is so broken and irregular that it appears from a distance as if lacerated into shreds. In this portion, masses of stumps may be seen between straggling patches of bush. Clearings have been made right into the heart of the forest, and what remains has been left by the natives only on account of the steepness of the ground, making cultivation difficult. These forests are generally situated on south slopes, easily accessible from the native settlements in the location. The altitude varies from 4,750 feet to 3,800 feet. The rainfall on the wooded range of hills is said to be unusually heavy, and the forests should be preserved if only on account of their great regulating influence on the flow of water. The principal timber trees seen were Yellow-wood, Stinkwood, Sneezewood, White Ironwood, White Pear, Wild Chestnut, Camdeboo Stinkwood, Natal Mahogany, Bogabog and Beukenhout. There does not appear to be any kind of supervision exercised over these forests.'

At an elevation of between 5,500 and 6,000 feet lies about a square mile of forest, the Hlatikulu forest. "The climate is cold, and frosts are prevalent in winter; thunderstorms come from the east; misty rains from the south; and easterly gales are common." The remarkable thing about this patch of forest is that it is stocked mainly with Hard-pear *Olinia cymosa*, this useful tree averaging about 400 cubic feet to the acre. Of the four principal timber trees of South Africa, Outeniqua Yellow-wood, Stinkwood, and Sneezewood are absent, while Upright Yellow-wood exists only in a stunted form. Ironwood, more abundant than useful, in the forests of South Africa generally, is here happily scarce.

In the Zikali location, the forests are numerous but all of small size; they occupy deep gorges in the North flank of the Drakensberg mountains, which here reach their highest elevation between Cathkin Peak (10,357 feet) and Mont aux Sources (11,170 feet) the culminating point of South Africa. The country is very rugged, and the grandeur of the scenery is not surpassed in Natal. From Mont aux Sources, the Tugela leaps down some two thousand feet, to form the highest waterfall in the world. The most

accessible forests have been cut out, or nearly so, and Kafir cultivation and wattle-cutting have served to damage the greater number. The timber trees belong to the species found at Hlatikulu, but Stinkwood occurs again up to the Lobonjo River, a tributary of the Tugela. A characteristic tree of this region is the mountain cypress *Widdringtonia cupressoides* which forms isolated clumps or forests at high altitudes.

The Berg Cypress is a curious South African tree remarkably like the ordinary Cypress in appearance. It is *never* abundant or gregarious in Cape Colony and reaches its best development at elevations of 2,000 feet in the Knysna forests and 4,000 feet in the Eastern Forests.

(To be continued.)

Timber Carting in Surrey.

The North West corner of Surrey, bordering on Hampshire and Berkshire, contains a large amount of Forest land. It is in this corner that the grand old Windsor Park exists, and where the Cæsar's Camp Forest, the joy of the Coopers Hill Foresters, is being brought into existence; and Swinley woods, Bagshot Park and Heath, Ascot and Bracknell, are all celebrated for their beauty. The nature of the woodland is very varied, the pine and chestnut almost side by side with beech and oak forests.

I do not propose, however, penetrating the details of the forest land, and have merely prefaced this article with the above remarks to show that timber felling and carting is a daily occurrence in this locality. There are several steam sawmills in this district, and wood of all kinds is brought to these mills by carts of the kind I propose to describe.

I was greatly astonished at the amount of timber brought in on one of these carts. I have now seen, on several occasions, upwards of 60 cubic feet of oakwood, and 80 cubic feet of Scotch pine and larch brought in by two carthorses on one of these carts. I have also wondered whether these carts could not be drawn by elephants in India. I have not personally had much experience of elephants; but I know that in the Godavari District in Madras, efforts were being made to ease the load for elephants by means of small trucks, and that the experiments in this line were not successful.

The cart may be said to consist of four parts:—

(1) Shafts; (2) Front; (3) Pole; (4) Back.

The shafts consist of two shafts (*aa*) joined at their hinder ends by two crossbits of wood (*b, c*) and an iron brace (*d*), the latter bolted to the shafts (*a*) and front cross-bit (*c*) with bolts and nuts. Into the back of the hinder cross-bit (*b*) are screwed two rings (*e*), through which passes an iron bar (*f*) belonging to the front.

The front consists of three horizontal beams (*g h, k*), $5\frac{1}{2}$ feet long, 6 inches broad, and 5, 7, and 5 inches high respectively. The first of these has an iron plate (*g'*) rivetted on to it, and also kept in place at its ends by means of caps (*g''*) bolted through the beam.

The beams (*g* and *h*) are kept 5 inches apart by means of four uprights (*e*) of 4 inches scantling; but the beams (*h* and *k*) lie one on top of the other, being kept together merely by the iron bolt and nut (*m*), which passes also through the axle box (*o*), and possesses a ring at its end for tightening it.

The beam (*k*) is separated from the axle box (*o*) by two small pieces of wood of 3 inches scantling. Above and below the beam (*k*) passes, being let into that beam, a frame (*ijj'j''*). The crosspiece (*j*) of this frame has rings through which the bar (*f*) passes, and so connects the shafts with the front.

The pole (*p*) is about 20 feet long and six inches in diameter. It is connected with the front in three ways; firstly, by means of a ringed fork (*q*), the fork of which is bolted on to the pole (*p*) and the ring of which the bolt (*m*) passes through; secondly, by the pole resting on the cross piece (*j''*) of the frame (*ijj'j''*); and thirdly, by means of two iron rods (*r*) fitted to rings in beam (*g*) of the front, and bolted with bolts and nuts to the pole (*p*).

I would draw attention to the fact that these front wheels can turn without disturbing the position of the logs, as the logs keep the top beams (*g* and *h*) in their position, whilst the lower beam (*k*) the frame (*ijj'j''*) and the axle box (*o*) take the direction of the front wheels, the beam (*k*) revolving under the beam (*h*) by means of the bolt (*m*). Nor are the pole and the piece (*j''*) of the frame fastened together; so the piece (*j''*) merely slides under the pole.

Now, in the back part, this pivoting arrangement is unnecessary; at the same time the back must be capable of a longitudinal motion along the length of the pole; so that if very long logs are brought in they may be evenly balanced by sending the back further away from the front; or if very short logs are being transported, the back must be sent forwards nearer the front.

The back only possesses two horizontal beams separated by four uprights. These beams are $5\frac{1}{2}$ feet long, 6 inches broad, and 5 and 7 inches high; the distance between them being 10 inches.

There is a frame as in the front (*ijj'j''*) but of a different shape, being V-shaped instead of rectangular, two curved iron pieces (*j'''*) keeping them together.

The pieces of the front (*n*) are found at the back; but, instead of being placed outside the frame, they are placed alongside where the pole passes through the back.

The iron bars (*r'*) of the back are not fastened to the pole, but to the V frame (*jj*). Another iron piece (*v*) is fastened to the pole, round which the chain (*t*) passes.

The method of keeping the back in position is the following. First the pole is passed through the hole formed by the pieces (*h n o*) cut round to receive it; the V shaped piece (*j*) then fits round the pole, the iron pieces (*j'*) passing over it. Two chains (*κ*) start from rings, fixed on to the back on each side of the pole, and are fastened on to a ring above the pole. Another chain (*t*) passes through this ring, and through the piece (*v*), and joins itself by means of a hook on the end of the chain (*t*), hooking one of the links of the chain (*t*).

The cart is now ready for the logs to be placed on the top of the beams (*g*). To prevent the logs slipping off, an iron bar (*α*, in the "front" sketch) can be placed in each of the holes made at the top of the beam (*g*), in the plates (*g''*).

Now, suppose the cart is in the position shown in the diagram, and that the log to be mounted is on the near side of the cart, and about 5 feet from the wheels. A piece of wood, with a

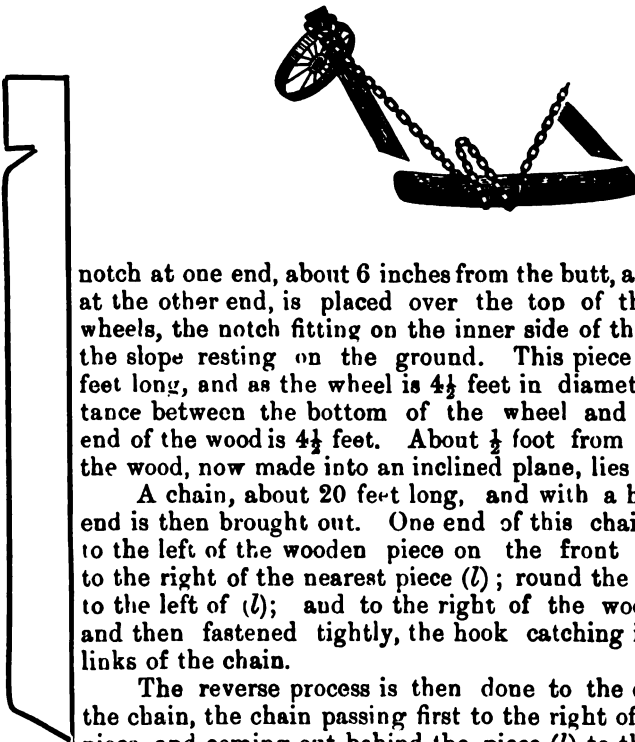

notch at one end, about 6 inches from the butt, and sloped off at the other end, is placed over the top of the two near wheels, the notch fitting on the inner side of the wheel, and the slope resting on the ground. This piece of wood is 9 feet long, and as the wheel is $4\frac{1}{2}$ feet in diameter, the distance between the bottom of the wheel and the sloping end of the wood is $4\frac{1}{2}$ feet. About $\frac{1}{2}$ foot from the end of the wood, now made into an inclined plane, lies the log.

A chain, about 20 feet long, and with a hook at each end is then brought out. One end of this chain is passed to the left of the wooden piece on the front wheel; then to the right of the nearest piece (*l*); round the back of (*l*); to the left of (*l*); and to the right of the wooden piece; and then fastened tightly, the hook catching in one of the links of the chain.

The reverse process is then done to the other end of the chain, the chain passing first to the right of the wooden piece, and coming out behind the piece (*l*) to the left of the wooden piece.

The chain is then passed below the log and brought over it again, and forms a loop in the manner shown in the figure. Another chain is then brought

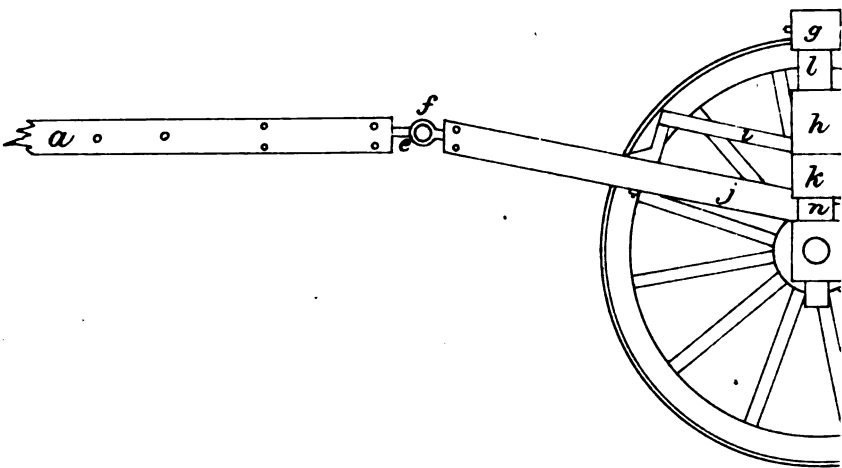

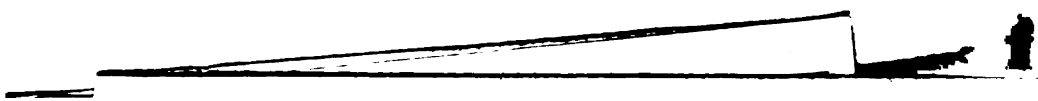

-
-

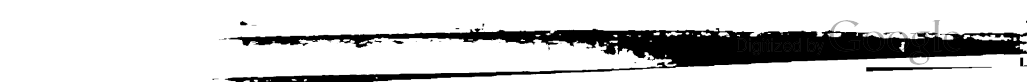

out, hooked at each end and one hook is passed through the loop, and the other fastened on to the harness chains of the horse on the other side of the cart, over the pole. The horse is then started off, and the log rolls up the pieces of wood on to the cart beam (*g*), and at a great pace. In fact, the pace is so great, that sometimes the log, colliding with the iron pieces (*a*, in the figure of the front) fitted in the holes on the far side, either jumps the cart or knocks the cart over.

I have seen one horse mount an oak log of 30 cubic feet; but it was unable by itself to mount one of 42 cubic feet, two horses, however, easily accomplishing it.

When one log is up, the chain that joins the harness to the chain loop, passes over the first log; and in this way, I have seen 9 pine poles mounted on one cart.

A. W. LUSHINGTON.

Cutch and its Adulterants.

(Continued)

In our last I said that I would refer to some of the more important adulterants of Cutch used in this country. This I will now attempt to do.

Before entering into details, I might state that the adulterants most generally used are decoctions of the bark or wood, as the case may be, of Than, Taukgyan, Lein and Hpangah and to a lesser extent of Pyingado and Pyinma.

The bark of the 'than' tree (*Terminalia Oliveri*) after being chopped up fine is boiled in earthenware pots in water until all the essences are extracted from the bark. The liquid thus obtained is then boiled with the essences similarly obtained from the chopped up wood of the cutch.

Cutch thus adulterated can be detected as follows; if only a little 'than' be used, little or no harm is done, but the resulting cutch is of a slightly brighter colour and more metallic. If large quantities, however, of the 'than' be used, the cutch cakes break with a peculiar metallic fracture, are less bitter in taste and have a slightly different smell. When largely adulterated with 'than,' cutch loses its good properties, goods dyed with it lose their colour when washed and owing to the absence of tannin, leather tanned with cutch thus adulterated is of little value.

Both the bark and the wood of this species are used; if the former, the same process is followed as in adulteration with 'than,' if the latter, the same method as in boiling cutch itself is followed:

Taukgyan adulteration. *Terminalia tomentosa*.

Adulteration with 'tauk-kyan' can be detected by breaking the cutch cake when the fracture which at first is very bright, soon clouds over, losing its lustre, the smell is different and the taste, instead of being very bitter, is mawkish. In addition to the above differences, the weight of the cutch adulterated as above is lighter. Owing to the absence or at least small amount of tannic acid in the bark and wood of tauk-kyan, goods dyed with this mixture soon lose their colour.

The same process is followed when 'lein' is used as an adulterant as in the case of 'than.' The chopped up wood is not used.

If a stick is thrust into a soft cake, when drawn out, the adulterated cutch will appear hanging on to the stick in long threads.

If a small quantity of lime be mixed with cutch adulterated with either 'lein' or 'tauk-kyan' it turns almost liquid, but if the lime be added to unadulterated cutch, instead of becoming liquid, it becomes hard.

Hpangah, *Terminalia chebula*, was 2 or 3 years ago largely used in the Majwé district to adulterate cutch, but the way in which it (is or) was used is unknown to me.

F. J. BRANTHWAITE.

Rate of growth of Teak in the Magayi Plantations, Burma.

The following measurements have been taken during the month of January 1892 and represent the state of the plantations from 1872 to 1877 immediately after thinning out has taken place. The girth measurements were made at the usual 'breast height' 4 feet 3 inches. The areas operated over, in each case (except 1873) = $\frac{1}{10}$ th acre, were not fair average samples of the whole plantations of the year, but were taken from the better portions only. The plantations had all been made at 6' x 6', with the exception of 1876, where lines of Teak and Pyinma alternated, the plants being 6 feet apart in the lines. At first, the Pyinma (*Lagerstroemia flos reginæ*) was of slower growth, but during 1883 and 1884 it had to be cut back to protect the Teak, which now practically stands in lines 12' x 6'. The actual number of measured trees is multiplied by 10 to give the results per

acre. It may be of interest to note, as helping to give information in regard to the shade-bearing capacity of Teak, that at the time of thinning, the following countings were made:—

1872.	Blanks or dead suppressed poles ...	570	
	Dominated poles ...	310	
	Poles forming the actual canopy ...	330	
			1,210
1875.	Blanks or dead suppressed poles ...	590	
	Dominated poles ...	310	
	Poles forming the actual canopy ...	310	
			1,210

The plantations are all on the plain and not in a locality favorable to the growth of Teak either as regards soil or situation. At the time of formation of the plantations the soils were thus described:—

1872. Sandy with a sub-soil of impenetrable clay, but at a considerable depth.

1873. Sandy with an impenetrable sub-soil and not so deep as in 1872 plantation.

1874. Similar in character to that in 1872 and 1873.

1875. A sandy loam, ground undulating gently.

1876. Better drained than that of the plantations to the west (1872 to 1875) and composed of the detritus of the rocky strata (sandstones, conglomerates and shales) which form the Yoma; surface covered with small pieces of a conglomerate (feruginous sandstone with quartz pebbles).

1877. Similar to that of 1876 Plantation—

<i>Girth in Inches.</i>	1872. <i>No.</i>	1872.	
14	20	Average stem 22" in girth, samples measured shewed the growth in height to be 60 feet on the average.	
15	20		
16	20		
17	20		
18	20		
19	30		
20	30		
21	30		
22	20		
23	20		
24	50		
25	10		
26	10		
27	...		
28	20		
29	10		
Total	... 330 per acre.		

The largest girth noted in the plantation was 3 feet 5 inch.

<i>Girth in</i>	1873.
<i>Inches.</i>	<i>No.</i>
12	8
13	21
14	38
15	22
16	53
17	45
18	30
19	22
20	30
21	38
22	22
23	8
24	8
25	...
26	...
27	7

Average stem 18" in girth, samples measured showed growth in height to be 57 feet on the average.

Total — 352 per acre.

The sample area in this case was $\frac{2}{15}$ of an acre.

<i>Girth in</i>	1874.
<i>Inches.</i>	<i>No.</i>
14	20
15	40
16	20
17	40
18	30
19	10
20	10
21	60
22	30
23	10
24	20
25	10
26	10
33	10

Average stem 21" in girth, samples measured showed growth in height to be 55 feet on the average.

Total ... 320 per acre.

<i>Girth in</i>	1875.
<i>Inches.</i>	<i>No.</i>
14	20
15	10
16	10
17	40
18	20
19	30
20	40
21	30
22	10
23	10
24	50
25	20
26	...
27	10
28	...
29	10

Average stem 21" in girth, samples measured showed growth in height to be 60 feet on the average.

Total ... 310 per acre.

<i>Girth in Inches.</i>	1876. <i>No.</i>
12	10
13	30
14	80
15	40
16	30
17	30
18	60
19	30
20	30
21	10
22	...
23	20

Average stem 17" in girth, samples measured shewed growth in height to be 43 feet on the average.

Total ... 370 per acre.

<i>Girth in Inches</i>	1877. <i>No.</i>
11	70
12	40
13	30
14	30
15	70
16	60
17	30
18	20
19	30
20	20
21	10
22	10
23	10
24	...
25	...
26	...
27	...
28	...
29	10

Average stem 16" in girth, samples measured shewed growth in height to be 42 feet on the average.

Total 440 per acre.

ABSTRACT.

Plantation.	Age.	Dominant Poles forming canopy.	Average Girth (Inches).	Average Height (Feet).	Average Annual increment in—	
					Girth (Inches).	Height (Feet).
1872	... 20 years	330 per acre	22"	60'	1'10"	3'0"
1873	... 19 "	352 "	18"	57'	0'94"	3'0"
1874	... 18 "	320 "	21"	55'	1'16"	3'0"
1875	... 17 "	310 "	21"	60'	1'23"	3'5"
1876	... 15 "	370 "	17"	43'	1'06"	2'7"
1877	... 15 "	440 "	16"	42'	1'06'	2'8'

3rd February, 1898.

J. N., RANGOON.

A note on the Californian Poison Oak.

(*Rhus diversiloba.*)

The green leaves are generally 4 to 5 c. m. long and 2.8 to 3.0 c. m. broad, not sessile, simple and serrated more or less deeply. These serrations are not, however, present on the whole circumference of the leaf, but only on portions of it, and their extent varies in individual leaves, moreover the serrations are only even on both sides of the circumference of the terminal leaf of each twig; and on such leaves they occur over an approximately equal length of the middle portion of both sides of the circumference, the depth of the serrations in each side being practically similar. The base of the terminal leaf and its sharply pointed apex remain unserrated. The two leaves below the terminal leaf spring from the stalk at right angles and as regards the half circumference nearest the terminal leaf, are generally without serrations, except on the terminal third or quarter of the upper end of the leaf, whereas the serration on the half circumference furthest from the terminal leaf begins much nearer to the base of the leaf, and it therefore follows that each leaf shows a varying length of serration on each half of its circumference.

The color of the leaves in the middle of October was bright to dark green, but the leaves had then already in some cases assumed their autumn colouring of a beautiful crimson as in the wild vine of Europe.

The shrub attains a height of several metres and requires always to be supported; in Blackbear gulch where my observations were made, this support is generally given by the evergreen *Quercus chrysolepis* or Live Oak, and this circumstance has doubtless given rise to the local name of "Poison Oak" to the plant.

The shrub is extremely common in Blackbear gulch being found at the foot of the forest clad slopes in that locality, those slopes being densely covered with an undegrowth of various species overtopped by *Quercus chrysolepis*, *Sequoia sempervirens* and a pine tree, which are probably the types of a high forest once existent there. There is probably no species which is credited with being so virulently poisonous as this shrub; from the evidence of an inhabitant of Blackbear gulch, inflammation is caused by handling the leaves or twigs; exposure to the smoke of the burning wood produces redness of the skin and swelling of the whole body and the application of the sap to the human skin is followed by severe blistering wherever the fluid touches.*

* NOTE.—Some of our Indian species of *Rhus* have a blistering sap, *Rhus vernicifera* for instance, and we remember to have once had some bad sores on our hands caused by the sap of *Rhus acuminata*. Hon. Ed.

It is indeed asserted that some persons feel ill effects from merely visiting Blackbear gulch which, at any rate, proves that the roads in that place pass close to the forests. The ill effects of smoke and sap from the poison oak are supposed to last unless proper antidotes are applied, from 4 to 6 weeks; in one instance the swelling of the eyes was so pronounced as to cause total blindness, but those who have once suffered from the poison are apparently inoculated and the effects of a subsequent exposure to it are not so severe. As an antidote which will at best only limit the effects of the poison to one week, it is customary to rub the part affected and the whole body with salt and water, immediately afterwards to rub in alum powder on the wet skin. Personally, however, I cannot vouch for the dangerous qualities of this plant, for I have cut off twigs and have experienced no inflammation of the hands, but this need not prove the ill effects above narrated to be fabrications, for I had been warned of the danger and took special precaution, and moreover it is possible that the poison is more virulent in spring than in summer. In the same way, I would not assert that the smoke from the combustion of the poison oak could seriously affect human health, until more careful observations of its effects have been made, but I believe that the plant may be injurious in the spring during its flowering, when the atmosphere in its vicinity is charged with pollen and this would also explain the ill effects felt by those who only passed the plant at a distance. If it could be proved that persons exposed to the smoke from the burning wood of the poison oak suffered seriously in health, then this species would be the most harmful, as well as most useless in creation, for alive it is injurious and felled it produces not even fuel and moreover the plant attracts the so called Forest rat which rodent forms its nest under this shrub, where it is secure from interference by man.

Quercus chrysolepis, *Rhus diversiloba* and the forest rat form a remarkable community of three, well worthy of consideration.

The first affords the least shade of all the timber trees on the slopes of the Blackbear gulch. The second, which requires a support and cannot thrive without light, finds its requirements best met by the presence of the first and is therefore found associated with it, whilst the third whose chief enemy is man, finds a better protection in the poison oak than in any other species, and takes up its abode under the shadow of that shrub. Thus the presence of the Live Oak is conducive to the welfare of the poison oak and that again to the welfare of the Forest rat. The circumstances which regulate the well being of plants are so various that the attainment of this being involuntary, must be purely accidental. The seed of all light-demanding species, for instance, which falls on the ground below shade-giving trees, may come to nothing, whilst similar seed falling under trees with light canopy, germinates

and springs up. But it is otherwise with animals, for here volition steps in and combats the adverse circumstances of existence. Take the case of the Forest rat. The disturbance and destruction which it suffers from the hands of man when it lives under the protection of other species have obliged this animal to recognize and take advantage of the protective qualities of the Poison Oak. The human race has been prevented by the struggle for existence from permitting the intellect to remain inactive and has been forced to increase and improve it by use, so animals are forced, in a similar manner, by the urgency of their surroundings, towards the development of their senses and instinct. (Leo. Anderlind in the Forst und Jagd Zeitung : translated by S. E.-W.)

S. E.-W.

II. CORRESPONDENCE.

The Warrant of Precedence.

SIR,

I have been recently looking into the Warrant of Precedence and have been somewhat surprised to find that the only Forest Officers who appear in it are the Inspector-General of Forests and Conservators. Now why is this? How is it that District Superintendents of Police of the 1st and 2nd grades are given rank in it, while Deputy-Conservators of the same grades, whose pay, position and responsibilities are practically identical, are omitted? Surely there is something wrong about this. I note that the Warrant of Precedence was drawn up in 1877, some 15 years ago, when the Forest Department was still in its infancy and barely recognised, and possibly the officials who drew up the list did not consider the Department of sufficient importance and maturity to be more fully represented. Since that date, however, the Department has asserted itself, and now unmistakably stands forth as one of the leading and most important Departments in India, with a staff of officers equal, from a social and intellectual point of view, to any in the country. It is too absurd to think that Deputy-Conservators of the 1st and 2nd grades most of whom are men of 18 and 20 year's service should be placed below Police Officers and others of the same standing in Government Service. The Warrant of Precedence, as it now stands, is clearly obsolete, and it is quite time steps were taken to revise it and include in it more grades of Forest Officers.

While on this subject it occurs to me that the position of Forest Officers, and in fact of all officers generally of similar standing in other Departments, calls for consideration and adjustment quite as much as that of officers of the Medical Department whose claims have recently been recognised. This want of some recognised rank not unfrequently imposes on Forest Officers a slight, which they otherwise would be free from. For instance, Forest Officers from Deputy-Conservators of from 20 to 12 years service and downwards, having no rank of any kind, through no fault of the host, have to file into dinner, which in an up country station is invariably more or less of an official function, after Captains, no matter what the length of their service may be. Considering that officers serving Her Majesty in the Forest Department are recruited from the same class of men as officers in the army, it is but reasonable to expect that they should be placed so an equal footing with them and accorded such rank as will correspond with the different grades in the army. The corresponding grades would be as follows:—

Inspector-General of Forests	to rank with	Major-General or Col.
Conservators of Forests	„ „ „	Lt.-Colonels.
Deputy-Conservators 1st and 2nd grades	„ „ „	Majors.
Deputy-Conservators 3rd and 4th grades.	„ „ „	Captains.
Assistant Conservators	„ „ „	Lieutenants.

questions of seniority being determined by length of service in each rank. Trusting this matter will catch the eye of some of our Chiefs,
I am &c.

D. F. O.

The Formation of Dew.

SIR,

In the last April number of the *Indian Forester*, A. S. expresses his surprise at seeing a deposit of dew on the under surface of some large stones lying on the ground under some mango trees, the upper surface of the stones and the ground being perfectly dry. He has evidently not read recent papers on the subject of the formation of dew, in which papers the well-known fact, that large quantities of moisture are constantly rising up from the ground is for the first time given its full significance. It is chiefly and almost entirely the condensation of this vapour, warm from the interior of the soil, that produces dew. Hence, the under side of sufficiently large bodies in contact with, or close to, the ground, will always receive the first and heaviest deposit of dew except when the air is already at sundown near saturation, and the sky is at the same time

clear and there is no obstacle to radiation, in which case the rapid radiation from the upper exposed surface will give these the precedence. A.S., who has, if I mistake not, been in the black cotton soil districts of the Central Provinces, will remember to what a depth ($1\frac{1}{2}$ -2 feet) he has found in the morning the loosened soil of the fields saturated with moisture, thus accounting for the luxuriant growth of the cold weather crops without any artificial watering. Every one who has hunted for insects under stones in the hot weather, knows how cool and moist the surface in contact with the ground is. In the dry season, when the nights have ceased to be very cold, although dew may be deposited on exposed surfaces, yet it may be evaporated as quickly as it is deposited, so that there is at no time any appreciable moisture on them. We foresters, who pass more than half our lives in tents, must all have noticed how damp carpets become under heavy portmanteaux, boxes, &c. the air underneath being unable to circulate sufficiently to dry the moisture as it rises up out of the ground, and is condensed and absorbed by the cooler carpet.

E. E. FERNANDEZ.

A Plea for our Feathered Friends.

SIR,

I venture to think that the utility of birds in the economy of nature has been somewhat underrated in the Indian Museum Notes, an extract from which appeared in your April number.

They are useful to mankind chiefly in the following ways:—

1. In the destruction of agricultural pests.
2. In the dispersion of seeds of forest trees and shrubs.
3. For their æsthetic value.
4. For purposes of sport.
5. As a source of food supply.
6. As scavengers.

The immense value of insectivorous birds is, of course, undeniable, but it is not universally the case in this country that few of them are ever destroyed for the sake of their plumage. A list of birds shot for this purpose in the Dehra Dûn District was prepared in 1885 by Mr. Clifford, Assistant Conservator of Forests. It comprised no less than 235 distinct species, including birds from nearly every one of the insectivorous families mentioned in the Notes.

I am not at all sure that many of the birds which are both grain and insect feeders, do not do more good through the insects they destroy, than harm through the grain they devour.

I remember a celebrated case in some large German province where the farmers had to spend money in re-introducing such birds, which they had previously ruthlessly exterminated.

The important aid afforded by birds in the propagation of plants, more particularly those bearing succulent fruits, is not, I believe, fully realized. It has been admitted that birds are one of the chief agents in gradually clothing recently formed islands with vegetation, but it is apt to be overlooked that this process of distribution is also daily going on, although in a less striking manner, on all lands throughout the world. In this utilitarian age, in which the struggle for life is so acute, and where, alas! in many instances, all is subordinated to L. S. D., everything that tends to raise man's thoughts above the counting house, should be most strenuously preserved. Of all animal life, birds probably give the greatest pleasure to humanity, by their beauty of form and colour, the marvel of their flight, and in many cases the sweetness of their song. How often have they inspired our poets and artists? Where would the art of Japan be without them? The different effects on the mind of an Indian Jungle teeming with bird and animal life, and of a New Zealand Forest, with its death-like stillness, requires to be felt to be believed.

I wish also to put in a word for sport. There is very little to be said in favour of the big *battues* which in England have but too often taken the place of the good old style, and I should be the last to wish that anything of the sort should be encouraged in India at the expense of the agriculturist. But sport in India, as now conducted, has everything in its favour; it is a healthy and manly form of exercise; it helps to keep body and mind in full vigour; and greatly relieves the monotony of existence in many of our rather dull Indian Stations; it takes men out of large towns and Cantonments and brings them face to face with Nature. I believe, therefore, its value to Government and to the country to be very great indeed. Game birds, too, are found mostly in the wilder parts of the country where there is but little cultivation, so that their depredations on the cultivator's grain are not usually serious.

As a source of food supply, wild birds are not of a very high importance; but still in India, where meat is so inferior, they are a pleasant addition to the ordinary fare and deserve consideration even on this account.

Vultures, so disagreeable in themselves, are of the highest value as scavengers, and crows also are very useful in this respect. I would by no means wish to see all crows and starlings condemned to destruction on the ground that they do more harm than good. Crows, besides their duties as additional sweepers, are, I believe, most useful in destroying such agricultural pests as wire worms, in which they are ably assisted by mynahs and starlings, a small body of whom may generally

be observed following the Indian plough. Even the rose-colored starling which is often so destructive to grain, is sometimes of the greatest service, the *Pioneer* states that "the flights of locusts which were so prevalent last year have almost all succumbed to the combined attack of insect parasites and 'Rosy pastor starlings'" This bird also helps in the reproduction of the mulberry.

I would say, then—let us try and preserve all birds except those whose criminality has been proved to the hilt. It is with sorrow that I am forced to condemn the noisy but destructive, although beautiful, parrots. I would also declare war à l'outrance against the hawks and kites.

The birds in India are one of the glories of the country, and bird-life is abundant almost everywhere. Is there not a danger in the future that with the increase in the number of cheap fire-arms and their possession by numerous unscrupulous sportsmen à la français, this glory may become a thing of the past? I should therefore rejoice to see a Wild Bird Preservation Act passed by the Government of India, on the lines of the English Act, but modified to suit the requirements of the country. The Act should, in my opinion, be very general, with powers to the various Local Governments to make rules under it, applying the act to certain areas, fixing the close seasons, and so forth.

TAU THA.

A Departmental Blazer.

DEAR SIR,

I think Z's suggestion of a motto in the May number an excellent one as tending towards "*esprit de corps*," for humanity is so constituted that it rallies to a colour, a name, a flower, and so on, while sounder things move it less. If, then, the monogram I. F. S.* with a crown above and a motto below, is adopted, we shall have a neat and sensible badge free from pretentious vulgarity.

By way of a first suggestion for the motto, I give "By flood and field" but possibly some one may be able to suggest something more suitable from a latin poet.

If the Blazer is to come off, some steps should be taken and perhaps you, Mr. Editor, could form a small Committee to draw up details, publish what it proposes in the "*Forester*" and note that these proposals will be considered as accepted, unless objections are raised. Everything should be clear, as to what firm would supply the Blazer, who would be entitled to wear it.

T.

*Note.—We regret that by mistake last month, the letters I. F. S. were referred to 'Indian Forest School, instead of, of course, 'Indian Forest Service.'

HON. ED.

IV. REVIEWS.

Administration Report on the Railways in India.

This large Volume (Part II) is by no means so uninteresting as its bluebook appearance would make one imagine at first sight. There are three most interesting maps which shew (1) the principal centres of traffic with the statistics of that traffic (2) the distribution of traffic in 1890, and (3) the several systems of railways corrected up to September 30th, 1891. To any one who is fond of maps, and who has travelled at all in India, these three will give pleasure ; we have ourselves spent some time over them and expect to spend more as they give so much useful statistical information in themselves that an additional reference to statistics is rarely necessary.

Some of our readers may be interested to have a few Indian Railway statistics for January 1st, 1891. On that date India possessed 16,177 miles of Railway, representing a capital of 20,571 lakhs of Rupees. In the previous year those Railways had earned 2,062 lakhs, with an expenditure of 1,024 lakhs, so that the net profit was 1,038 lakhs or Rs. 6,417 per mile all round. To work these lines, 3,707 locomotives are used with 80,802 vehicles of all sorts. On the whole, the interest on the capital only exceeded the net earnings for the second half year of 1890, by 15 lakhs. Of interest to Forest Officers is the amount of fuel consumed, which seems to vary very much in different lines. Of the chief broad guage lines which use coal, the East Indian burnt 292 lbs of coal per mile run ; the North-Western 294 lbs ; the Oudh and Rohilkhand 286 lbs ; the Great Indian Peninsula 392 lbs ; the Bombay Baroda and Central India 247 lbs. Of the chief metre guage lines, the Rajputana burnt 298 lbs ; the Bengal and North-Western 303 lbs ; the South Indian 262 lbs ; and the Burma Railway 259 lbs. Of those which burn wood, the only broad guage line is the Madras Railway which consumed 820 lbs. per mile run ; while of the narrow guage lines, the Southern Mahratta burnt 1097 lbs and the Rohilkhand-Kumaun 723 lbs. so that, roughly, it may be said that the amount of wood required to do the work of 1 lb of coal is $2\frac{1}{2}$ lbs.

Appendix D gives a full account of each of the Railways, in which we find some information which may be of interest to our readers on the description of sleepers used on the different lines. We learn that the East Indian Railway was originally laid almost entirely with wooden sleepers, but that cast iron ones have since been introduced on the main line, while on the Jubbulpore branch, creosoted fir and sál sleepers are in use. The Tirhoot Railway is laid with sál, deodar and iron sleepers. the Bairagnia branch having pynkado. The Bengal and North-Western uses sleepers

of sál and creosoted pine. The Rohilkhand-Kumaun is laid with sál chiefly. The Bengal-Nagpur Railway, although it runs for such a distance through forests of fine sál timber, uses steel, except on the Umariá-Katni branch, where it is laid with sál. The Indian Midland uses oval pot sleepers weighing 80 lbs to the bowl. The Rajputana-Malwa Railway is laid with deodar and creosoted pine, but the latter are perishing very fast and are being gradually replaced by deodar. The Wardah Valley Railway uses wooden sleepers of teak, sál or creosoted pine. Dhond—The Manmad uses an iron pot sleeper of 94 lbs weight. The South Mahratta Railway also uses iron except on the Mysore section where teak and creosoted pine are employed. The short Hyderabad extension is laid with 'pea-pod' iron sleepers, as is the Villupuram-Guntakal extension of the South Indian, the rest of which was originally on creosoted pine, which is gradually being replaced by steel or iron pot sleepers; though the Nellore branch is partly on Denham-Olphert's, partly on 'trough' or 'pea pod' sleepers.

The North-Western Railway uses partly wood (probably all deodar), partly cast iron round pot sleepers, though in small lengths, other kinds are occasionally spoken of. Of the Oudh and Rohilkhand it is mentioned that the permanent way was first laid "partly on cast iron oval bowl and partly on wrought iron saddle-back sleepers," but other kinds are in use, and altogether, out of 692 miles, 407 are on cast iron bowls, 68 on wrought iron saddle sleepers, 199 on steel Maclellan and Smith's patent and 18 on wood. On the Northern-Bengal Railway, creosoted pine, sál, redgum and wrought and cast iron sleepers have been used. Pynkado sleepers are used on the Sittang section of the Burma Railway. We are not told what kind is employed on the Irrawaddy section, or on that to Mandalay; but on the Mu Valley, teak, pynkado, ingyin and theya are in use.

The great Indian Peninsula Railway was formerly originally laid on wooden sleepers, but these are being partly replaced by iron bowls; and the same may be said of the Bombay-Baroda and Central India main line. On the Madras Railway, "The South-West line, was originally laid with sleepers of indigenous woods 'but an experiment was made of using stone blocks 2' x 2' x 1' which, as the experiment was unsatisfactory, were renewed in 1857. The jungle wood sleepers were found to be very 'short-lived, and in 1861 it was decided to replace them by 'Greaves' patent cast iron bowl sleepers and this alteration has 'proved to be economical and in every way satisfactory."

The Nizam's State Railway is laid partly with Bessemer's steel sleepers, partly with steel 'pea pods.' On the Jammu-Kashmir Line, deodar is to be employed.

We have to apologize for this somewhat dry communication, but we think it is not an uninteresting thing to put it on record and with these apologies we close our notice of a wonderfully clear and well arranged Report.

Raising Strawberries from Seed.

Certain kinds of Strawberry may be raised from seed with advantage, in the following manner :—The largest and ripest strawberries are gathered in fine weather, and are crushed under water by the hand. When the pulp has been sufficiently liquified the seeds fall to the bottom. The liquid is decanted off, and the seeds are spread out on bibulous drying-paper in the shade. The paper is changed as often as may be found necessary, and when completely dry, the seeds are put away in linen bags and kept in a dry place until the following spring.

A bed in the garden must be thoroughly cultivated, the soil well sifted and manured. The seed is mixed with twice as much fine earth, and is sown in April, either in lines, or broadcast. The seed is beaten down gently, and a little very fine soil scattered over it by means of a riddle; the bed is then covered with a thin layer of moss and watered.

A month afterwards, the moss may be removed every evening or on cloudy days. In July or August, the plants are pricked out six inches apart, into another bed and all runners are cut off. At the beginning of September, the plants are put out into their final resting place, the future strawberry bed, at about 12 inches apart. Watering must, of course, not be forgotten.

So far, the Agricultural Review of the Mauritius, from which we have extracted the above method. The advantage of raising strawberries from seed appears to be that you can perpetuate some choice varieties, especially those which bear their seed prominently on the outside, instead of having them embedded in the pulp. We do not know how far this plan would succeed in India, but it is worthy of trial.

A. S

The Berar Forest Report of 1890-91.

The Berar Forest Report for the year 1890-91 appears to be a record of a year's successful administration of the forests of that Circle. The Berar Forest Law and Rules framed under the same have not as yet been brought into force, but these were expected to be introduced shortly after the close of the year and their working will no doubt lead to improved conservation, the regulation of the various classes of forests being, it is believed, one of the chief objects of the rules in question.

A good deal of work appears to have been done in the preparation of Working Plans, these having been prepared for the Pempanga and Medsi Reserves and for the Pathrot Forest. A rough scheme of working for the Grazing Lands of the

Darwha Taluk has also been prepared. The Report states that these Grazing Lands contain a good deal of forest growth and indeed at present constitute the source from which the people mainly derive their supplies of forest produce—the regulation of their working is therefore of more immediate importance than that of the Reserves which are not being worked. The scheme referred to groups the Grazing Lands into convenient Working Circles and lays down regular order of fellings in each: the régime being coppice with a liberal reservation of standard. A scheme was drawn up for working Amraoti Hills Forests, which seems to have been urgently required. Data are also being collected with a view to the framing of Working Plans for the Teak coppice forests in Akola, Buldana and Basim. Purchasers have apparently hitherto been allowed to cut the Teak poles themselves in these forests and the discovery of the abuses to which this system led has necessitated a change, felling now being done by departmental agency and the wood sold by auction. This plan, it is said, answers well, and will doubtless be more satisfactory than the old system.

The results of fire protection during the year were on the whole good. Out of a total area of 711,296 acres under special protection 694,290 acres were successfully protected or 97·6 per cent. The area attempted was 33,549 acres in excess of that of the previous year and the total cost of protection per square mile Rs. 7-2-0.

The question of the future management of the Grazing Lands has received the attention of the Resident. Para 49 of the Report states that "It had been proposed to resume the 'free grazing lands, which are tracts which were given at the 'settlement in villages where land was available for free grazing. 'The tracts are, from the nature of things, very unequally distributed, some villages have enough and to spare while others 'have none. To remedy this state of things it was proposed to 'resume the free grazing tracts and in lieu allow free grazing 'in any Government grazing land to a certain proportion of 'plough-cattle to all." The scheme was introduced into three Districts, in 1884, and 1885, and works fairly well; but owing to objections raised to its introduction into the other districts matters have been left in *statu quo* until the revision of the settlement.

Natural reproduction is reported to be backward in the South Berar Forests owing in a great measure to the want of complete fire protection, very few portions of these Reserves having it appears been successfully protected for five years consecutively. The conditions of successful reproduction were found where several layers of old grass had spread themselves on the ground and become more or less rotten; with these conditions, it is stated, Teak often comes up readily in the open. In the Melghat Reserves, where these conditions are

found, the forest is reported to be perceptibly filling up, the largest amount of Teak reproduction and advance growth occurring in the open patches on gently sloping ground. As regards artificial reproduction, the Conservator records his opinion that Nature aided by protection is doing more in these Melghat Reserves in one year than can be done artificially in twenty. Cultural operations in other forests consisted largely of broadcast sowings which are condemned as failures. If, as is stated, numbers of natural seedlings germinate yearly in these forests only to die off, and do not shoot again in the rains, it would no doubt be hardly reasonable to expect any very satisfactory results from broadcast sowings. If the above is really the fate of the natural seedlings, it is no doubt due to the absence of the conditions referred to above as being brought about by protection.

The financial results of the year are the best on record. the surplus of Ra. 3,18,501, being double what it was five years ago, a result which should be very gratifying to His Highness the Nizam.

V. SHIKAR.

A Man Eater.

The following may be worth recording. In the hot weather of 1887, a tiger, which had evidently come across from a neighbouring district, commenced slaying. The first victim was a lad of some 12 summers; he and his father were sleeping on the ground in the verandah, and between them and the outer enclosure was a cattle shed. The tiger got in without molesting or disturbing any of the herd, and seizing the boy bounded off with him over the small fence. On another occasion, he similarly killed an old man while asleep, but leaving him, made off with a child lying by his side. The Deputy Commissioner now considered that some special action was necessary and directed the D. S. P. and myself to do the needful. We thereupon visited the localities concerned and had several beats but with no success. The D. S. P. and I then separated, each going on his own official tour, but before doing so, we made all arrangements for tying up "baits" in the shape of young buffaloes and worthless used up old bullocks. Very shortly after, one and then another of these were taken, and from the day our first "gara" was killed, the slaying of human beings entirely ceased. A few weeks later we (the D. S. P. and self) met on an appointed date

at the locality and found that the tiger was actually lying up in a small narrow ravine not 300 yards from the village where we were camped, and on the night previous he had not only taken our "bait" but had killed a village cow (which had strayed off and remained out) within a stone's throw of where our tents were pitched. The ravine at this part contained dense brushwood, but was only some 50 yards wide and 200 yards long with cultivated fields all round. As far as we could ascertain, the tiger must have been living here for at least ten days previous to our arrival but had caused no disturbance whatever among the villagers, though they must all have been aware of the close proximity of the dreaded enemy. Luckily, the week before this I had secured the Conservator's staunch and tried elephant; she did all the driving and without her I don't believe any number of men would have made that tiger move from his lair, at least without one or more of them having been mauled. There was only room for one gun, and the honor fell to my rifle [a single .500 Alex-Henry-Express which has done all my shooting from Bull bison down to the chikara]. A score or more of men on either side of the ravine yelled and shouted, and shots from off the elephant were fired, but Stripes made no response. At length, the elephant advanced and breaking down small saplings and shrubs made a violent commotion by beating these about frantically and thus forced him out. Many of these feline species make themselves small and try to slip away, but not so with this one. With head erect and without uttering a sound he walked into the open, and did not so much as make an attempt at a rush to get to cover some distance further on. After rolling over to the first pill he actually got up and sat on his hunkers like a dog and gazed straight up to the top of the tree beside him. I then gave him his quietus. This tiger was beyond his prime and measured 9 feet 6 inches [they seldom, if ever, have a length of 18 feet in these parts] he had in him three solid spherical bullets, one on the side of his head, another in his foot, and the third far back in his body, these may have been fired from some machine; for at that time two sportsmen (?) were trying the slaughter of tigers in that way in the adjoining district, and one of them, poor fellow, died shortly afterwards from the effects of a mauling received in following up an animal that had been wounded from a "machine."

In concluding I may mention that our luck stuck to us: on the following day at our next camp we bagged another splendid male tiger which also fell to the first plug from an express bullet:—he measured a little over 9 feet but in breadth and other dimensions was huge and weighed much more than the "man eater." A few days after this the monsoon rain of 1887 burst, and the tiger season was at an end.

18th February, 1892.

E D.

VI. EXTRACTS AND NOTES.

The comparative value of various Fuels.

To enter into a full discussion of the scientific methods by which the relative heating values of the different materials used as fuel are ascertained, would be tedious, and at the same time possesses little practical value to the majority of the readers of the *Gardeners' Chronicle*; but the following general statement of the principle upon which such values depends, may be of interest to many whose business demands considerable outlay in this direction.

It has been found, as a result of elaborate experiments, that the heating-power of any fuel, whether coal, coke, charcoal, wood, peat, or turf, is approximately proportionate to the percentage, by weight of the carbon which it contains; hence, coke, consisting as it does, almost entirely of carbon, in a greater or lesser degree of purity, takes the lead as a heat-producer. Anthracite, a good sample of which contains 90 per cent. or more of carbon, heads the list of coals. Its hardness and compactness, and the absence of flame-producing constituents render a strong draught and careful stoking essential for its economical combustion. Other hard Welsh or steam coals have from 75 to 90 per cent., the average being about 84 per cent. Newcastle coals average 82 per cent.; Derbyshire, 80 per cent.; Scotch, 71.5 per cent.; and Lancashire, 78 per cent. Of course, extreme variations, upwards and downwards, are found in all the above districts. Again, the "heat-value" of any fuel is modified by the presence of (1) water, as such, or of (2) the uncombined hydrogen and oxygen in the proportion in which they unite to form water, *i.e.*, eight parts by weight of oxygen to one part of hydrogen. The greater the amount of water, or of its constituent gases, the smaller becomes the heating power of the fuel.

The reasons for this are not far to seek. The heat disengaged in combination (using the word in its ordinary sense), depends upon the chemical combination of the elements contained in the substance burnt with oxygen of the air—the carbon with oxygen forming carbonic acid gas, the hydrogen with oxygen forming water. It is clear, then, that any elements existing in a fuel already in a state of combination, are, from a heat-producing point of a view, so much waste material.

With regard to the presence of the hydrogen in an unconfined state, the case is somewhat different. Here the

hydrogen combines with oxygen (present in the fuel itself, or in the air), the union being attended by the generation of a very large amount of heat, far greater than would be the result of the combination of an equal weight of carbon. How then can the hydrogen be considered disadvantageous to a fuel? Simply because a more than compensating amount of heat is used up in raising the temperature of the water to the boiling-point; and in its conversion into steam. This will readily be understood, when it is remembered that as much heat is required to raise a pound of water from freezing point to boiling-point as would raise a pound of iron to about 900 centigrade (a bright red heat), and that five and a half times as much heat would be needed to turn a pound of water at boiling-point into a pound of steam at the same temperature.

The deductions from theory are fully borne out by the results of practical experiments, it being found that the heating power of fuel varies directly as the amount of carbon, and indirectly as the quantity of water and its elements, or incombustible ash contained.

Here we are met by an apparent paradox, which has led to much misconception, and consequent error in practice, and which is therefore deserving of the attention of practical men.

It was first shown by Bunsen, that when steam is passed over red-hot carbon, it is decomposed; the glowing carbon uniting with the oxygen to form carbon monoxide and carbon dioxide, and the hydrogen passing off partly uncombined. The carbon monoxide and the hydrogen unite with oxygen (forming water and carbonic anhydride respectively), and the amount of heat thus generated is found to be greater than would be evolved in the ordinary combustion of the carbon without the intervention of the steam. This application of water-vapour must, however, be carried out with great care, for when present in excess, it decreases, rather than augments, the heat generated. The proper way to apply water for raising the temperature is to place it in an open pan beneath the firegrate, thus utilising the heat which is radiated downwards from the fire for its vaporisation. Many have fallen into the error of wetting coal before placing on the fire, with the result that the amount of heat has been lessened rather than increased, as is evident from what was said above. It is possible that coke, if fresh, may be advantageously damped in moderation, but it has the power of absorbing a large amount of moisture from the atmosphere without any sprinkling.

Too much emphasis cannot be laid upon the necessity for careful and intelligent stoking, no matter what the class of fuel employed. Careful trial should be made of various kinds used by any particular furnace, and the stoking should be carried out in such a manner as to ensure perfect and complete combustion. If anthracite or other hard coal be used, for instance, thin fires

and a strong draught are essential. The importance of stoking was well seen in a case that came under the notice of the writer during the hard frosts of last winter. The furnaces of a market-nursery were stoked for some time by a gardener whose only idea seemed to be to pile on the coal. A man who had had some years experience, an engine-driver in a factory, was then put on stoking duty with the result that, in much colder weather, the coal consumption was reduced considerably.

In conclusion, the main question as to which is the most economical fuel for glass-houses, is one that can only be determined by actual experiment with each system of heating, and by considering, independently and in conjunction, the heat-value of the available fuels, the cost of each, and the kind of boiler used.

The following table, taken from Scheerer's *Mettallurgie*, may be useful, as indicating the relative heating effects of different fuels, although the figures must be taken with caution, as being the result of theoretical deductions rather than that of practical experiments with ordinary boilers.

FUEL.	HEATING POWER.
Good coke, with 10 per cent. moisture and 5 per cent. ash	... 2350
Best coke, 5 per cent. moisture, and 3 per cent. ash	... 2400
Best coke, no moisture, and 3 per cent. ash	... 2450
Air-dried black wood charcoal, 12 per cent. moisture	... 2450
Anthracite, 5 per cent. moisture, 5 per cent. ash	... 2350
Caking coal, 5 per cent. moisture, 5 per cent. ash	... 2300
Sinter coal, 5 per cent. moisture, 5 per cent. ash	... 2250
Lignite, various	... from 1800 to 2200
Turf peat (without moisture)	... 2000
Turf peat, 30 per cent. moisture	... 1575
Air-dried wood, with 20 per cent. moisture	... 1575
Kiln-dried wood, with 10 per cent. moisture	... 1675
Kiln-dried wood, without moisture	... 1750

(C. W. H. G. in *Gardener's Chronicle*.)

The Pencil Cedar Industry.

The pencil cedar (*Juniperus virginiana*) trade is developing very rapidly outside of the territory that formerly supplied the demand, notably Florida. Latterly, very large purchases of cedar have been made in the south, and the quality of the wood is quite satisfactory to the foreign trade. This is more of an industry than at first would be supposed, and the *Timberman of Chicago* states that Germany, Austria included, makes 200,000,000 cedar pencils annually. France has four factories, England four, and Russia two; these three countries probably producing 150,000,000 cedar pencils annually, making the European production

350,000,000 cedar pencils each year. These figures are too great for the average reader to grasp the full meaning of them, and yet there are not more than twenty or twenty-five pencil manufacturers in the entire world. Of course these estimates do not take into account the cheap basswood pencils used for carpentering, and that class of work. Pencil lumber is cut into "slats" of $8\frac{1}{2}$ centimeters in length, 54 millimeters in width and 5 millimeters in thickness. These "slats" are put up in boxes by producers in the United States and shipped abroad. Out of two of these "slats" three pencils are made, they being placed one on top of the other with the lead in the centre and then the two portions of the "slats" are securely glued together. Rosenbaker & Co., of Hamburg, Germany, are at present conducting a large business with America in this line, and will also introduce the Bosnian style of staves of American manufacture into Germany.—(*Timber Trades Journal.*)

Creosoting Sleepers.

The practice of the Eastern Railway Company of France in creosoting sleepers is described in a recent issue of the *Revue Générale des Chemins de Fer*. Sleepers as delivered are stacked and seasoned in the open air. They are then adzed and bored by a special machine, loaded on trucks, and run into a drying oven, where they remain twenty four hours or more. After drying at a temperature of about 167 deg. Fahr., they are run into a metal cylinder 6 ft. 3 in. in diameter and 36 ft. long, which is hermetically closed. The air is exhausted, and a partial vacuum is maintained for about half an hour. Communication is then opened with reservoirs of dead oil, which is allowed to flow in at a temperature of 176 deg. Fahr. under pressure. When the oil ceases to flow under moderate pressure it is forced in by a pump up to a pressure of 83 lbs. per square inch, and this pressure is maintained for an hour and a quarter. Communication with the oil reservoirs is then opened again, and the excess of oil not absorbed by the timber flows back into the reservoir. The cylinders hold 168 sleepers each. The quantity of oil absorbed is measured by determining the difference in volume of the oil before and after operation. The wood used is principally oak and beech. The oak sleepers absorb from 2.4 to 2.7 quarts per cubic foot. The whole operation takes about four hours. This method of treatment has been practised by the company since 1865, with, it is stated, very good results. After fifteen years of service the sleepers taken out have been 15 per cent. for creosoted oak and 50 per cent. for creosoted beech.—(*Ibid*)

Is it good to dig about Trees ?

This is a question that will very well bear discussion. We know that of old the question was answered practically in the affirmative in the parable of the unfruitful tree, where the head gardener pled for the tree, that it might be suffered to remain until he had dug about the roots and manured it. There would probably be ninety answers in the affirmative, to ten in the negative, if the question were asked off hand. But when we come to look around us and find that there are trees growing in certain places, green to the utmost point of the tallest branches, but which trees are never dug about the roots from year to year, whilst other trees that are regularly dug about, perhaps twice or thrice a year with the result of a sickly habit and poor yields of fruit, it begins to make one doubt whether, after all, it may not be better, in some cases at least, to leave the trees a little more to nature. A very large number of our fruit-trees—notably the orange—send out innumerable fibrous roots close to the surface, and every time the soil about these trees is dug, the spade cuts away or mutilates these roots, so that the foliage is either not sufficiently nourished and drops off, or an excessive call is made upon the few remaining roots, and, as a matter of course, the points of the shoot or branches fail and die. Such a phenomenon is often witnessed where trees are planted upon very stony and unsuitable ground, or upon a shallow soil possessing a stiff subsoil of clay. The roots cannot get down deep enough, and the supply of moisture in dry weather is not sufficient for the growth that was made in spring ; therefore some of the growth has to be sacrificed, and in a very few years such trees assume an aged and worn-out appearance.

There are a very few persons who advocate a deep and thorough breaking up of the soil in the first place, but particularly retaining the relative positions of surface and subsoils, and then leaving the orchard alone except as to weeding and pruning the trees. Some, indeed, go further, and maintain, with much probability in their argument, that the surface should be planted with grasses, which by permeating the soil, and through the operations of worms, &c., keep the surface aerated and sweet, and give the fibrous roots of trees every opportunity of ramifying the earth. Once every year they would give a good top dressing of old leaf mould or thoroughly decomposed manure from the stable, but beyond this and pruning they would do nothing. It is also maintained that the grass keeps the roots of the trees shaded and cool, but this office would be quite as effectually performed by the foliage and branches if the tree were in proper health and vigour. One great fault in some fruit-growers is that of trimming up the stem to make a tall

tree, which exposes the trunk of the tree to the fierce rays of the summer sun, by which the bark becomes backed, hardened, and incapable of properly conveying the sap, and the roots are at the same time dried up from the same cause. As the tree gains age, the effective working fibrous roots are extended further and further from the bole or stem, and to properly shade these roots the branches should be near the ground and extend a considerable distance around. There are certain plants that will grow beneath the shade of trees, and if planted under a young tree it will be observed that the plants near the stem are stunted and dwarfed, while the outer rings increase in vigour as they extend from the centre. With an older tree, a contrary effect is produced, the plants nearer the stem are full of vigour, whilst the outer rings dwindle away to the smallest size. This is due to the fact that the young trees have extended their fibrous roots to only a very short distance from the stem, and of course absorb all the moisture and nutriment from the earth beneath the other plants, but under the older trees the opposite is the case, and the outer plants are drained, whilst those near the stem of tree gain a supply. Where the trees naturally send their fibrous roots to a good depth below the surface, it is highly probable that the practice of digging about the tree is beneficial; but it certainly is opposed to common sense to suppose that the annual destruction or mutilation of the effective feeding roots of a tree should promote its health and luxuriance. On the contrary, it appears calculated to inflict serious injury, and the dying away of the topmost branches of peach, apricot, and plum trees might perhaps in most instances be attributed to this practice. A good mulch of old litter around the roots of an old tree if not around the stem—has very often prolonged its life and vigour, whilst digging away its roots would have inevitably killed it.—(*Ibid*)

Olive Oil in the South of France.

The olive harvest in ordinary seasons commences towards the latter part of the month of November, but the oil produced at this period is unsatisfactory in every point of view, because it is derived from olives collected from the ground, where often they have been lying for some time. These windfalls, so to speak—dry, diseased, and frequently worm-eaten—give an oil only fit for industrial purposes, machine-lubricating &c. It is only towards the end of December that the olive commences to yield an oil which can be used for alimentary purposes, and from this date almost to the end of May, when the manufacture finishes, the oil continues to improve in ratio with the maturity of the fruit. In January, the operation of shaking the trees commences. The fruit which falls is generally unwholesome and

unripe, nevertheless it affords an eatable oil, which is brought into commerce under the technical name of "Fine" or "Surfine Courante." The manufacture of this quality extends to mid-February, or even later, the oil improving as the harvest proceeds. In March the olive is really ripe; during this month the gathering from the trees actually commences, and from this crop is produced the oil of superfine quality and well adapted for keeping. This stage of the harvest continues through April and May. During the last few weeks of the harvest, the fruit yields the "Extra," of exquisite flavour and delicate pale-straw colour, and capable of retaining all its good qualities for two years if properly treated. In exceptional years, when the trees give an abundant crop of fruit, the oil-pressing may continue through June, the oil then obtained is locally known as "Arrière Saison." It is wanting in flavour and keeping quality, because the fruit has suffered from the effects of the southern summer. The olive tree blossoms in May or June, when it still bears the fruit of the previous season. A manufacturer, anxious to supply a really perfect article, must take extreme care in selecting the appropriate time for collecting the fruit, or, in spite of his manipulative skill the result will be unsatisfactory.

After the olives have been collected, they are at once passed to the mill, where they are crushed under stone rollers until reduced to a uniform paste, which is transferred in a special kind of grass bag, and submitted to pressure. Fine flavour and freedom from rancidity are best ensured by moderate pressure; but much depends upon the time which elapses between the harvesting and the pressing. Fermentation, or heating of the olives, through keeping, exercises a very injurious effect upon the oil, which, when it issues from the pressing-sack, is thick and is cloudy. Perfect limpidity is only obtained by repeated filtration through layers of cotton-wool arranged in specially constructed trays. After final clarification, the oil is stored in large cisterns, or underground tanks technically known as "piles." Many of these have a capacity of 50 tons. This system of storage effectually preserves the oil from atmospheric influences.

The question of packing for transport is an important one. The well-known old-fashioned terra-cotta jar, with its glazed interior, is still the most esteemed, but is fast giving place to the wooden cask. The tin plate or metal vessels are condemned, as they impair the delicate flavour of the oil and hasten rancidity, especially in the summer. In storing a stock of oil, the coolest and driest place available should be selected. Upon arriving at its destination, the oil should be left some days at the normal temperature, as the sudden transition from heat to cold is very trying to it. During this period of repose the bung is taken out of the cask and replaced by a piece of linen, arranged so that the air may penetrate freely. This process restores the limpidity frequently lost in transit. In case of freezing of fine table oil, great

precaution is taken to thaw it at the lowest possible temperature. Oil which has once been thawed is more liable to freezing, and no oil thus treated should be poured back into stock. With regard to bottling, only sufficient oil for current sales is bottled at the time, as a few weeks are sufficient to deteriorate the article. The custom of buying oil six months or a year in advance cannot be too strongly condemned; the crop being an uncertain one both in quantity and quality, the result is that the buyer will either pay too much or will obtain an inferior quality. The proper time for buying is also an important question to consumers, who should be guided by the period of production. In normal years the oil is made and exported thus:—the "Fines" and "Mi-Fines" at the commencement of January; "Superfines Courantes," the middle of January and February; "Superfines Superieures," end of February; "Extra," in March; and finally the best oil, known as "Vierge," in April.—(*Chemist and Druggist.*)

Forestry Lectures in Edinburgh University : Season 1891-92.

The course of lectures on Forestry, in the University of Edinburgh, which have been conducted during the past two months by Colonel Fred. Bailey, R.E., ex-Director-General of the Forest Department of India, were brought to a close on the 30th ult., when the students who had passed their examinations were presented with the certificates they had gained. That the lectures attracted a number of earnest and diligent students was well exhibited by the marked success of those who came up for examination. This gratifying result indicates the progress that forestry, as a science, is making. The expounding of the natural laws and scientific principles which underlie and guide practical forestry in its most successful issues has many attractions for students; but the need of a knowledge of forestry in all its details, particularly those applicable to Britain, is impressing itself on the minds of owners of land and those engaged in its management. In addressing his class at the conclusion of the last lecture, Colonel Bailey explained the circumstances in which, at short notice, he had undertaken to deliver the course just ended. He had confined his attention to the utility of forests, and the fundamental principles of forestry. These were the same for all kinds of trees, growing in all countries, although the application of them should be varied in accordance with the peculiar characteristics of each species, and the climatic and other conditions under which each grows. It was therefore of great importance that a thoroughly sound knowledge

of these principles should be acquired. The special treatment to be adopted for each species in Scotland should be regulated in accordance with the most careful local observations of silvicultural facts; but the existing record of such facts was, generally speaking, very meagre indeed, and did not extend continuously over any lengthened period of time. A commencement to supply such deficiencies should be made, and the lecturer urged that members of his class, and others who were in a position to do so, should make careful notes of physiological facts relating to Scottish forest trees in all their various stages of life. Such notes he observed, would be of the greatest value to the Professor of Forestry, who would thereby be enabled to direct his teaching in full accordance with the ascertained requirements of the various species of forest trees in this country. An accurate account of all work done, of produce removed, and receipt and expenditure of money in connection with every wood, should be kept on all estates. Colonel Bailey then explained the arrangements he proposed to make for the session of 1892-93, commencing on October 26th next. The class list of the past session shows the names of forty students, and the average attendance during the whole course has been twenty-nine. Of the twelve students who presented themselves for examination, one gained a First class Certificate, while seven have gained Second-class Certificates,—an excellent record considering the shortness of the session.—(*Gardeners' Chronicle*).

Seeding of Bamboos.

We see, in the papers, that in Mysore bamboos (probably *Bambusa arundinacea*) are seeding profusely. From Assam we hear of the seeding of the 'Tarai' (*Melocanna bambus-deoides*); from Darjeeling of that of *Dendocalamus Hamiltonii*; while several species, including *Gigantochloa albo-ciliata* and *Bambusa Tulda* are reported in seed in Burma. We should be glad to record in our pages the dates of seeding of other species.

VII.—TIMBER AND PRODUCE TRADE.

Churchill and Sim's Circular.

MARKET RATES FOR PRODUCTS.

(Tropical Agriculturist May 2nd, 1892.)

Cutch	per cwt	24s.	to	34s.
Croton seeds	" "	15s.	to	20s.
India Rubber, Assam	per lb.	1s. 6d.	to	2s. 2d.
" Rangoon	" "	1s. 8d.	to	1s. 10d.
Myrabolams, Bombay' good,	per cwt	10s. 6d.	to	11s. 9d.
" Jubbulpore "	" "	9s. 3d.	to	10s. 6d.
" Godavari "	" "	10s.	to	10s. 9d.
Nux Vomica—good	" "	20s.	to	11s.
Orchella	" "	20s.	to	25s.
Red wood	per ton	£3	to	£3-10s.
Sandalwood—logs	"	£35	to	£60
" chips	"	£9	to	£30
Sapan wood	"	£4	to	£7

THE
INDIAN FORESTER.

Vol. XVIII.]

July, 1892.

[No. 7.

The Forests of Natal

*Being an account of the Report on them, by Mr. H. G. Fourcade
of the Cape Forest Service, by D. E. Hutchins.*

Part 2.

The formation of dongas or what would be called "nullahs" in India, is thus described.

"A remarkable feature of the Drakensberg country, more particularly between the Hlatikulu and the Tugela Valley, consists in the powerful erosion of the soil by the summer down-pour. The hill sides are scored with torrential ravines, *dongas*, as they are called in Natal, of comparatively recent formation, which go far to disfigure the country and reduce the value of the land for agricultural purposes. Dongas are not found in normal conditions, and their spread is always related to the destruction of bush and herbage. It is probable that the burning of the veldt by which grass and bush are kept down, is the principal cause of their formation. The physical conditions of Natal are in many respects similar to those of the south of France, and equally favourable to the formation of torrents. We have the same sudden heavy rains falling over a hilly country sloping rapidly from the mountains to the sea; and there are unmistakeable signs that in Natal an outbreak of torrentiality is at present in an incipient stage. Floods are not unknown; those in April, 1856, February, 1866, and recently that of January, 1886, are reported to have been very destructive, and ravines, locally known as *dongas*, are already a conspicuous feature of many parts of the country. Possibly *dongas* do not yet incommode farming to any serious extent; but it should be borne in mind that one of their attributes is to spread at a continually increasing rate, and that even now, this rate, though it is yet small, is by no means insensible. Each one of the hundreds of *dongas* which I have seen in Natal, appeared to me of recent formation;

‘ and whenever any definite information could be got from
 ‘ old residents or natives, I found this to be the case. Some
 ‘ of the ravines known to have made their first appearance only a
 ‘ few years back, have now attained a depth of ten or twenty feet,
 ‘ and a greater width. The head of the Tugela Valley has been
 ‘ very much cut up by the summer showers, and dongas there
 ‘ extend for miles; the Tugela itself has every characteristic of a
 ‘ torrential river. When following the coast, the rivers of the
 ‘ colony, crossed near their mouth, look as if they were streams of
 ‘ silt and *débris* as much as streams of water.

‘ The diminution of the forests, and the practice of burning
 ‘ the grass in summer, which leaves the ground unprotected and
 ‘ liable to be loosened by rain and cattle precisely when the violent
 ‘ thunder storms occur, are sufficient causes to account for the
 ‘ increased guttering of the land. Indeed, the experience of other
 ‘ countries makes it necessary to explain why in Natal, with causes
 ‘ so potent, the effects are not already greater. The destruction of
 ‘ forests and of herbage has been severe only within a compara-
 ‘ tively recent period. The Hottentot races, which, a few centuries
 ‘ back, peopled South Africa, were neither pastoral nor agricultural,
 ‘ and their numbers remained small, so that the natural conditions
 ‘ of the country were but slightly interfered with; and it is only
 ‘ with the advent of more destructive races and their great increase
 ‘ in late years, that vegetation began to be checked and that even-
 ‘ tually the erosion of the ground was manifested, at first in an
 ‘ insignificant and protracted manner, then by degrees in a more
 ‘ and more rapid form. At present, the mantle of verdure which
 ‘ covers the mountains, still acts as a powerful brake on torrential
 ‘ action, but if we are to allow what remains of forest to be des-
 ‘ troyed, and the mountain grasslands to be burnt and grazed in-
 ‘ discriminately, the ruin of much of the land will become a matter
 ‘ of years, and perhaps it would not then be feasible to spend
 ‘ millions in redeeming it. While it is in our power to avert such
 ‘ consequences, we should profit by the experience that has been so
 ‘ dearly bought elsewhere, and not neglect to adopt any reasonable
 ‘ protective measures. Besides being cheaper, it is also better to
 ‘ preserve natural forests, than destroy them and substitute planta-
 ‘ tions which take centuries to acquire the deep layer of humus and
 ‘ the surface growth which give such a peculiar climatic value to
 ‘ the natural forest.”

Thorn Bush.—Below the high-timber forests of the Natal mountains, lie stretches of thorny scrub sloping towards the coast exactly as in the east of Cape Colony.

“ The Thorn Bush of Natal is spread over vast areas in the
 ‘ Midland region, at an altitude of from 1,000 to 3,000 feet. It is
 ‘ densest at the lower elevations, and a belt of grass country
 ‘ almost entirely separates it from the Heavy Timber Forests.
 ‘ Towards the coast, however, it merges gradually into the Coast
 ‘ Forest. It chiefly consists of various species of *mimosæ* of which

' *Acacia Natalitia*, *A. horrida*, *A. Kraussiana*, *A. Caffra* and
' *A. arabica* are the most noticeable. The distribution of Thorn
' Bush is shown in map I, and the Report of the Forest Commission
' of 1880 gives the total area covered by Thorn Bush as 196,000
' acres on private lands, but these figures appear to include Coast
' Forest, which would form an appreciable fraction of the whole.
' The clearing of Thorn Bush for firewood or for native cultivation
' has been very extensive of late years. The continually recurring
' grass fires arrest the growth of young plants, and the forest is
' seldom known to recover. Large areas may often be seen that
' are thickly studded with minute plants which would grow into a
' forest if protected from the grass fires. The Thorn Forests are
' usually ill defined and consist often of isolated trees or clumps
' thickly distributed over a large stretch of country."

Coast Forests.—The Coast Forest of Natal in a mild semi-tropical climate wherein flourishes the sugar-cane, the mango, the Madras cooly, and other tropical products—consists of a mixture of Cape and tropical species, the latter predominating. It is remarkable that in the list of coast species given at page 21 of Mr. Fourcade's report, occurs the Upright Yellowwood. In the east of Cape Colony, the Outeniqua Yellowwood is found in favourable situations near the coast but *never* the Upright Yellowwood. Nor does it occur at all abundantly in the mountain forests, till near an elevation of about 3,000 feet. Probably the Natal coast Yellowwood is that referred to at page 134 as *Podocarpus Thunbergii* var. *falcata*; and the common upright Yellowwood of the Cape, *Podocarpus latifolia*, Mr. Fourcade terms *Podocarpus Thunbergii* var. *latifolia*.

"With the exception of those in the Lower Umzimkulu Division, nearly the whole of the Coast Forests are situated on private property. It appears that surveyors have not hitherto considered coast forest to be forest within the meaning of their instructions, and it has been freely alienated; but what remains should be preserved as far as circumstances will permit. The Coast Forest is still extensive, but much of it has been cleared for planting, nearly the whole of the cultivated land in the Coast districts consists of cleared bush ground. This extensive denudation is said by old settlers to have somewhat altered the climate, causing a greater aridity and more irregularity in the weather. Yellowwood and wagonwood were formerly cut in many of the coast forests; but few good timber trees are now left. The Coast Forest is generally low, the average height varying from 30 to 60 feet. It contains a great variety of trees, the wood of some of which is of great value.

Descriptive Catalogue of Forest Trees.—Appendix I completes the description of the Natal forests. This is a Catalogue with a short, useful description attached, of the forest trees of Natal. It comprises 167 species and is the most complete of its kind yet published. It includes nearly all the

Cape timber trees and took its place at once in the forest libraries of South Africa. It may be noted that the tree with the curious name of "Bogabog" in Natal, is the well known and abundant "Wild Lemon," *Xylosma monospora*, of the Cape eastern forest; also that *Kiggelaria africana* is a handsome and abundant timber tree, the wild Peach of the Eastern forests of the Cape Colony, while *K. Dregeana* is the western species, rare in the Knysna forests where it is known as Fatherland's Rooihout. *Combretum salicifolium* and *Buxus Macowania*, believed to occur in Natal, are omitted from Mr. Fourcade's catalogue. Two useful alphabetical lists of vernacular and botanical names together with tables of relative strength and specific gravity, complete the Catalogue, which is prefaced thus:—

"In this enumeration, I have followed, for the sequence of the orders and genera, the "Genera Plantarum" of Bentham and Hooker, and retained for the orders their numbers in that work.

'A catalogue of this kind can only be rendered tolerably complete gradually during a period of years, and the present collection of notes, taken during the last few months, is necessarily wanting in many respects, but it is given in order to provide some source of information about the Natal woods.

'The forests were visited by me during last autumn and winter, when very few flowering specimens could be collected for determination. In the Drakensberg forests, many trees were identified from a previous knowledge of the species. In other cases, the determinations were made by comparison of the specimens in the Government Herbarium at Durban, and I should like to record my indebtedness to Mr. J. M. Wood, A. L. S., Curator of the Durban Botanic Gardens, for allowing me unrestricted access to the Government Herbarium, and giving me the full benefit of his unrivalled knowledge of the Natal flora.

Some of the genera of Natal plants have not been worked out in a full manner by botanists; and most of the species of *Acacia*, *Celtis*, *Ficus*, and *Cryptocarya* could not be determined.

'With the exception of two well-known woods that were not identified, all doubtful or undertermined species have been uniformly excluded."

Then follow interesting tables showing the growth of various indigenous trees grown in plantations in Natal compared with the results of observations on the same trees in natural forests at the Cape. The more important Cape species show the following yearly increase in girth (taken from trees growing in the main forest, Knysna):—

Hard pear: <i>Olinia cymosa</i>	1.17 inches.
Laurel: <i>Ocotea bullata</i>	0.95 "
Outeniqua Yellowwood: <i>Podocarpus elongata</i>	0.84 "
Upright Yellowwood: <i>Podocarpus latifolia</i>	0.48 "
The same in the Gouna forest	0.72 "
White Pear: <i>Apodytes dimidiata</i>	0.62 "

Plantations—Natal.

Outeniqua Yellowwood	2·02	„
Upright Yellowwood	1·18	„

In describing Stinkwood or Laurelwood, *Ocotea bullata*, at page 117, by "Kaffraria" is meant the Transkei. Very curiously and unaccountably, in what was formerly the colony of British Kaffraria, *Ocotea bullata* exists only as a rare botanical curiosity. In the forest country to the North-east and South-west of it, Laurelwood is abundant. *Ocotea bullata* is the most important forest tree in South Africa. It has a weak natural reproduction from a very perishable berry, but a remarkably strong reproduction from coppice shoots. Whether the trunk of the tree be cut by man, or left to decay, the stool produces an abundant sheaf of coppice shoots. But the berry decays, or, rarely, germinates while still on the tree; and all attempts to secure sound seed and raise the tree in nurseries on a large scale have failed. It seems possible that the curious geographical distribution of Laurelwood has to do with its abnormal natural reproduction.

The tree referred to at page 114 under the misleading local names of Ironwood and Coast assegai, is the well known and widely distributed Wild Olive, *Olea verrucosa*. This tree is hardly distinguishable from the common Olive of Southern Europe and North Africa, *Olea europaea*.

It should be noted that *Strychnos Atherstonei* scarcely occurs in the Eastern Province outside the Alexandria forests. Also that Sandalwood in India flourishes at a mean temperature of 74° not 82°, page 183. It, in fact, flourishes between mean temperature limits of 64° and 78°.

At page 116, the English and Dutch names for the common *Halleria lucida* are omitted. At page 185, the mean temperature of Perth, Western Australia, is stated to be 70° instead of 61°.

At page 189, *Pinus Pinaster* and *Pinus Pinea* are both entered as of moderately rapid growth. This is true of the latter, but the former (cluster or maritime pine) has, in these latitudes, a very rapid growth. I have seen a radial increase of 1 inch per year on recently cut pine stumps in the Cape Peninsula, maintained throughout the greater portion of the cross section. These two pines are thoroughly naturalized in the Cape Peninsula plantations, reproducing themselves easily from self-sown seedlings. There, it has been stated on good authority, the growth of the cluster-pine averages twice that of the stone-pine.

Before quitting this interesting report, special attention must be called to the figures of growth obtained from plantations in Natal. I have not met with any record of systematic measurements yielding higher figures than those given in my "Report on measurement of the growth of Australian trees on the Nilgiris," for the *Eucalyptus Globulus* or Blue-gum. This shows a yield of 12 tons of dry wood per acre, per year, for fully stocked plantations

up to 20 years of age. (After the lapse of 8 years, it would be interesting to learn whether, as was anticipated, this yield is maintained).* Now, Mr. Fourcade visited plantations near Maritzberg, the capital of Natal, where the rate of growth appeared to be close on three times that of the Nilgiri Blue-gum, *i.e.*, 30.5 tons of dry wood per acre per year. In the Nilgiri plantations, the rate of growth was calculated from actual measurement of all the trees in oblong shaped sample areas, taken through average portions of the plantations, thinnings and blanks being allowed for where they occurred. Mr. Fourcade took average diameters and heights, and reckoned thus the cubic contents of an average tree. Multiplying this by 302, the number of trees planted and still standing per acre, he obtained a yearly increment of 1,711 cubic feet per acre, equal to 30.5 tons of dry wood. It is possible that he may have somewhat over estimated his average tree and that the number of trees per acre may not be, as they appear, quite the same as originally planted. But he has since assured me that his figures admit of no doubt: and though the method adopted is less rigorous than that of actual measurement of the standing stock, I can not think there is any reason to doubt the substantial accuracy of these astounding figures. I have written to Mr. Schöpflin, now Conservator in Natal, calling his attention to them and suggesting a verification. Mr. Fourcade, convinced of the quite exceptional tree-growing power of the Natal climate, seeks an explanation in electricity. It is certain that electric storms are very frequent in Natal and that they are practically unknown in Knysna, while the ordinary conditions of growth—a hot sun, abundant moisture, and a fertile forest soil—exist in both localities. And it appears established from Mr. Fourcade's observations that under nearly identical conditions, tree growth, both in plantations and in natural forest, is greater in Natal than in Cape Colony.

The subject is extremely interesting and it is a practical one on which many Forest Officers might contribute observations, especially from the climates of India.

I have witnessed some remarkable electric displays in South-Africa, but nothing so intense as the breaking of the monsoon on the Western Ghats of India. Neither, I believe, is there anything in India to surpass the tree-growth in the Western Ghaut forests.

Production of wood.—In the case of gums, the rate of growth may be ascertained accurately, as there are sufficiently old plantations of the kind in Natal. Mr. Topham's plantation near Maritzburg, may be taken to be a fairly average one. The oldest plot, 40 acres in area, is 17 years old and consists of mixed *Eucalyptus Globulus*, *E. longifolia*, and *E. rostrata*, the rate of growth of each appearing not to differ widely. The trees are

* Note.—So far as our personal experience has gone, it has been fully maintained.

‘planted 12 feet apart, so that there are 302 to the acre; they
 ‘average 4 feet 10 inches in girth at three feet from the ground,
 ‘and 115 feet in height. Adopting the form-factor of 0·450 de-
 ‘duced by Mr. D. E. Hutchins from measurements in plantations
 ‘on the Nilgiris, the contents of each tree average 96·3 cubic feet
 ‘and the standing stock per acre 29,083 cubic feet, representing
 ‘a yearly increment of 1,711 cubic feet per acre. The weight of a
 ‘cubic foot of *E. Globulus* (dry wood with bark) averages 40 lbs.,
 ‘equal to 56 cubic feet per ton, according to Mr. Hutchins, and
 ‘the average density of the wood of the other species differs so
 ‘little, that it may be taken as being the same. The annual in-
 ‘crement in tons of dry wood per acre is thus 30·5 tons, and this
 ‘is a marvellous rate of growth. Individual trees even greatly
 ‘exceed this rate: one specimen of the *E. longifolia*, 17 years old,
 ‘being 12 feet 6 inches in girth at three feet from the ground,
 ‘and 115 feet in height.”

To the report is appended a note on forest meteorology. The remarkable periodicity of the rainfall in South Africa is thus referred to.

“The connection between forests, and rainfall in Natal is a
 ‘wide subject, that cannot be treated exhaustively without special
 ‘study, and more data than are at present available. The rainfall
 ‘fluctuates from year to year in an apparently irregular manner,
 ‘but, in reality, it is governed by cycles with regular periods.
 ‘My friend Mr. D. E. Hutchins, who has made a study of the
 ‘variation of the weather of South Africa in cycles, finds a close
 ‘connection between solar energy, as indicated by sunspots, and
 ‘the rainfall.* He also traces secondary cycles, one with a period
 ‘of 9·5 years, which he terms the “Storm Cycle,” from its associa-
 ‘tion with violent gales and numerous shipwrecks, the other with
 ‘a period of 12·5 years, which he terms the “Mitigation Cycle.”
 ‘Droughts prevail at the sunspot minima every 11·11 years
 ‘(Wolf’s Sunspot period), unless masked by a coinciding wave of
 ‘the “Storm Cycle,” or of the “Mitigation Cycle.” These three
 ‘cycles give, in the opinion of Mr. Hutchins, a complete key to the
 ‘South African weather, and the character of the season since 1884,
 ‘particularly last year’s severe drought, have been successfully
 ‘foretold by their use. The “Storm Cycle” is the most prominent
 ‘feature of the Cape Town rainfall, while the “Mitigation Cycle”
 ‘governs more powerfully the rains of the Eastern Province. I
 ‘have sketched a diagram which seems to indicate a close
 ‘connection between the waves of rainfall observed by Mr.
 ‘Wilkinson, at Ottawa, and the three cycles discovered by Mr.
 ‘Hutchins. To this, I may add that at Cape Town there are un-
 ‘broken rainfall returns for exactly half a century. During the
 ‘whole of these 50 years the only instances of unpunctuality in
 ‘the regularly recurring rainfall periods were:—that in 1862 the

* D. E. Hutchins. Cycles of drought and good seasons in S. Africa.
 (W. Wealey. 28 Essex Street, Strand, London.)

'rain came one year late ; and that the last sunspot rains, those of 1883, were slightly prolonged. The mean rainfall of the heavy rain years at Cape Town is 34·4, of the drought years 22·18 inches.

'These variations are sufficiently wide to be of practical importance ; and I am well within the truth in saying that the chances of successfully forecasting the character of the seasons are now as 50 to 1. Periodicity may be noted in the rainfall returns of other stations in the Southern Hemisphere ; but now here, as far as I am aware, are there data for founding regular cycles of drought and good seasons as at Cape Town."

Mr. Fourcade winds up his able and useful report with the following summary :—

1. "The Natal Forests, more particularly the Timber forests, have been shown to be well worth preserving, whether from an economic or climatic point of view ; and the Government alone is competent to undertake the work.

2. 'The condition of the forests is, for the most part, lamentable, and the result of past abuses ; their destruction is proceeding apace, and the following measures are recommended to ensure their preservation and utilisation to the best advantage.

- (a) 'The survey and demarcation of the principal forests.
- (b) 'Their protection from fire, from depredations, from destruction by natives or cattle, by means of suitable measures such as the clearing of fire belts, the establishment of small wattle plantations, the prohibition of wattle cutting and cattle grazing, with the aid of proper supervision and special legislation.
- (c) 'The closure of the forests pending survey, demarcation, and settlement.
- (d) 'The adoption of sound methods of forestry to secure a steady yield, improvement of the forest, and most profitable management.
- (e) 'The utilization of Colonial woods for railway sleepers.

3. 'Plantations of conifers and hard woods, designed to supply the future requirements of the country, can be made profitably along railway lines in the upland and the midland districts.

4. 'The most urgent work of a Forest Department in Natal would be to save what is left of the native forests; and plantation work should be deferred, till it can be undertaken without detriment to the progress of survey and demarcation."

To this I may add one recommendation. A glance at the instructive forest map of Natal given as a frontispiece to the Report shows how large a proportion of the high-timber forest has been alienated: in fact, all the largest and most accessible patches of timber forest are in the hands of private owners. This should be remedied, as early as possible. Along with funds for planting,

Parliament should be asked to vote a yearly sum for redeeming such forest as can be bought back at reasonable rates. Ordinarily, when a South African forest has been "worked out," the owner thinks about selling. He may be able to turn it into maize gardens and thence into pasture, but there is a chance of its degenerating into a thorny scrub, too expensive to clear. It takes many years of profitless watching and waiting to restore such forest, but for that very reason a little money goes a long way in redeeming it. A little money also will shift a good many natives to the safe side of a demarcation line. A Colonial Parliament will not lose sight of the fact that £180,000 goes yearly out of Natal to pay for imported timber.

Every well-wisher of Natal—and the plucky little English Colony, with its heavy burden of blacks, has many friends outside its own borders—will congratulate it on the earnest attempt now being made to restore its forests. And students of Forestry will everywhere hail with joy this latest addition to the already large list of Colonies and dependencies of England that have broken loose from the wasteful and inartistic traditions of a country, that sees nothing worth remedying, in the barren mountains of Wales, or, in the New Forest, as it is.

It is a goodly sight to see
What heaven has done for this delicious land ;
What flowers of fragrance blush on every tree,
What gladdening prospects o'er the hills expand !
But man would mar them with an impious hand !!

D. E. HUTCHINS.

Christen's Patent Dendrometer.

Most of the instruments of the present day used for determining the height of trees have the drawback of requiring a measured base line, and the laying out of this line, on steep ground or where there is much undergrowth is a lengthy operation which, if hurried, may result in incorrect data. This inconvenience is overcome in the Dendrometer under notice, by substituting for the measured base line, a staff of fixed length. The following is the principle on which the instrument works. Let $A B$ be the tree to be measured, O the eye of the observer, $a b$ a metal rod suspended so as to assume a perpendicular position, and so arranged that the upper end at a , furnished with a sight, cuts the

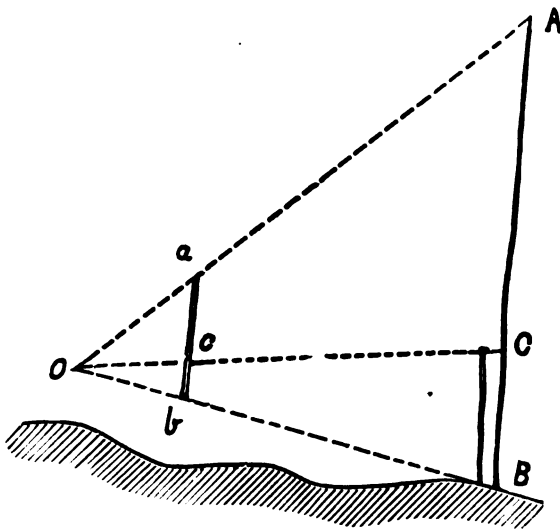

line of sight $O A$, and the lower end at b , also furnished with a sight, cuts the line of sight $O B$. $C B$ is the measuring staff placed upright against the tree, and c the point where, on the rod $a b$, the observer sees the top of the staff $C B$. Then $\frac{AB}{CB} = \frac{ab}{cb}$ and $cb = \frac{ab \times CB}{AB}$, $a b$ on the instrument is 30 c.m. and $C B$ is 4 m.

We must therefore, according to the above formula, work out the values of cb for all possible heights of $A B$, mark their positions on the metal rod $a b$ commencing from b , and with, opposite each mark, the corresponding height of $A B$. In practice, to measure the height of a tree, the measuring staff is held by an assistant at the foot of the tree, the rod is held between the finger and thumb of the left hand in such a position that the top of the tree is seen through the upper and the foot of the tree through the

lower sight, and whilst in this position a sight is taken at the top of the measuring staff along the line O C and the reading at c secured, which gives the height in metres of the tree at a glance. The length of the measuring staff is of course immaterial, so long as the figures in the metal rod are worked out on any given length of staff. The advantage of the new system is that it is dependent directly on to the sighting of the height of the tree and not on a measured base line and that there is much greater freedom is choice of a position from whence to take the observation, whilst if the left hand is steadied by resting it on a 5 or 6 foot staff, much greater exactitude may be reckoned on. Other recommendations are : the quickness with which observations may be made and the cheapness of the instrument which only costs 5s. 6d. With regard to accuracy, experiments have been made in measuring trees prior and subsequent to felling. For heights of 30 to 60 feet the variation was only 3 per cent. and for heights of 60 to 90 feet only 1.9 per cent. This instrument appears to recommend itself for cheapness, portability and accuracy to the notice of Indian foresters.

Extermination of Wild Beasts in the Central Provinces.

(And the system of Rewards.)

The article under this heading in the November issue, was no doubt read by all sportsmen and Foresters with much interest, since the question is such an important one.

From the perusal of it, it seems that the number of wild animals (for which rewards are offered) destroyed in the Central Provinces, steadily decreased since 1888. This is laid entirely at the door of the Shooting Rules. No doubt it is partly due to them, but the system of rewards for killing wild animals is responsible for a great deal ; so much so, that many sportsmen and others who are now thinking about the matter, are beginning to doubt the expediency of giving rewards, at any rate for tigers, who are responsible for most of the mischief.

In my opinion it is in this way. Native Shikaries are, as a rule, in the Central Provinces, badly armed and are perhaps inferior marksmen. However, they are desirous of earning the reward (which is Rs. 50.) all to themselves and thus when a " Sahib " comes into the field, they do *not* do their best to enable him to shoot tigers, except in places where they are not allowed to shoot themselves, for most " Sahibs " can hardly afford to give *each* of the attending shikaries Rs. 50 as a reward when he is successful in slaying a tiger. It is this desire of Native Shikaris to earn the rewards, that very often effectually prevents the

killing of tigers, since they are not often successful themselves in doing so, while they wound a great many.

If, however, rewards for tigers were stopped, all Native Shikaris would do their utmost to help the "Sahib" in pursuit of them, since then their chief chance of getting money would be from successful sportsmen. Sahibs are nearly always well armed and are as a rule fair, if not good, marksmen, and to encourage them is therefore the quickest and most effective way of decreasing the number of tigers. The number of sporting "Sahibs" is by no means small and with a little more encouragement given to them, the forests would be flooded by sporting parties. This particularly applies to Military men who at times find great difficulty in getting natives to assist them, and they almost all, as far as I know, would prefer to see the reward for tigers done away with, in order that native shikaris should be as keen as possible for the "Sahibs" to get a tiger, while, under the present system, they are not, except as I have said before, in places where they are not allowed to shoot themselves. As it is, in order to be successful in getting tigers, the plan generally adopted is as follows:—A man is found, who perhaps knows a little about shikar and he is told that he shall have the *whole* reward for everything that is killed, besides his pay, which is generally about Rs. 25 to Rs. 30 per mensem or more. This man does nothing, as a rule himself but "screws the tails" of the poor Gond and village shikari to make them do all the work necessary. These village or local shikaris, who know the ground, are the ones to whom all the credit is due, but although they work hard they are paid little for their trouble, while the middle man usurps all the credit and gets the whole of the reward into the bargain. These local shikaris, without whom, as a rule, sportsmen can do little, if they had shot the tiger themselves, would have got the Rs. 50 all to themselves. This is very unsatisfactory and the villager necessarily gets to look on shikar parties with dislike, if not something worse. With no reward offered, all villagers would be keen to help in the destruction of tigers, since they would have no means of making money from this source except from successful sportsmen.

I think I am right in saying, that natives are not responsible for very many of the tigers killed at present and it is doubtless a fact that they wound a very much greater number than they kill, as is testified by the old bullets found in tigers when they are shot. Of the other animals for which rewards are offered, (panthers, bears, hyenas, etc.) the greater number are probably killed by natives and, for these, it would perhaps be advisable to leave the rewards, as they are.

In the case of man-eating animals, it would direct the attention of sportsmen to the places where they are at work, if a list were published monthly by the Local Government of all such places where man-eaters are reported to be. If this

is not sufficient it might be advisable, perhaps, to have some reward for man-eaters especially, in out-of-the-way places. These man-eaters, however, will steadily decrease in number if natives are encouraged to help Sahibs to kill tigers, rather than attempt to kill them themselves, which would be the case if the rewards for tigers were done away with, and then, too, less tigers would go off wounded and become man-eaters.

This may seem to some a very selfish point of view, but it is not really, if the reduction of the number of tigers is what is aimed at. I have written this only in the hope that it may be seen that the Shooting Rules are not accountable for everything as "S" seemed to make out, although it is possible that they are responsible for part, since under the old rules, no one was allowed to shoot in *Fire-protected blocks* during the fire season. One word

Notification No. 6211 by the Chief Commissioner, C. P., dated 27th August, 1891.

about the new Shooting Rules. These, it must be confessed, put the Divisional Forest Officers in an awkward position. They are held responsible for the safety of their protected blocks, but under rule II (1) they should give permits between the 1st January and the 30th of June to *approved sportsmen and shikaries* for the exclusive purpose of hunting and killing carnivorous animals in those blocks. Divisional Forest Officers have, therefore, to distinguish as to who are "*approved*" sportsmen and who are not. Hence come odious distinctions which the Forest Officer is powerless to prevent. In these days of equality, he can hardly admit one and not another, without giving some reason and to admit all is out of the question, for if every one is admitted, it is "goodbye" to fire-protection. The only way is to refer all applicants who wish to shoot in fire-protected blocks to the Conservator and let him decide.

Cart and camel men are so very careless and when the forward camp is going on at night, as is the custom in the C. P., it is not to be expected they will go through dense jungle without a light or without smoking, however illegal it may be. If, however, people are admitted into fire-protected blocks it should always be on condition that two Forest Guards should accompany the camp, one with the forward camp and one with the rear camp, to see that all camp fires are extinguished and to see that cartmen do not carry a light on the road. The pay of these guards would, of course, have to be disbursed by the sportsmen whose camp they follow. It would be better if it were insisted that camps should be pitched outside the fire-protected block, as most Forest Officers themselves do when on tour.

It seems hardly right that Forest Officers should be placed in such an awkward position, when the whole responsibility of fire-protected blocks lies with them.

These new shooting rules have not, as far as I know, appeared in the *Indian Forester*, and I therefore enclose a copy for insertion.

P. H. C.

No. 6211-A.—*The following Rules framed by the Chief Commissioner, under Sections 25 (i) and 75 (d) of Act VII of 1878 (the Indian Forest Act), for the regulation of shooting, &c., in Government Forests in the Central Provinces, are published for general information. These Rules supersede all other Rules previously issued on the same subject under the same Sections of the Indian Forest Act.*

- I. The poisoning or dynamiting of rivers, streams or tanks is prohibited.
- II. (1). In a fire-protected forest during the period notified in the *Central Provinces Gazette* as the fire season or in any forest similarly notified as closed for shooting against the public generally, hunting, shooting, fishing, netting or setting traps or snares is prohibited, except under a permit in writing granted by the Conservator of Forests of the Circle or by the Divisional Forest Officer. No such permit shall ordinarily be granted between the 1st of January and 30th of June except to proven sportsmen and *Shikaris*, for the exclusive purpose of hunting and killing carnivorous animals.
 - (2). The permit may specify the number of elephants and camels (if any) and may limit the maximum number of retainers and followers, dogs and other animals that the holder may take with him into the forest.
 - (3). Forest Officers, Officers of the Central Provinces Commission, and gazetted Officers of the Central Provinces Police, having to discharge duties under the Forest Act, are exempted from taking out permits.
- III. (1). Permits under Rule II granted by the Conservator of the Circle shall be valid for any forest in the Circle. Permits granted by Divisional Forest Officers shall be valid only for the district in which they are issued.

Provided that wounded game may be pursued into an adjoining district or circle.

 - (2). Permits are granted gratuitously and are not transferable.
 - (3). The holder of the permit shall observe the close seasons prescribed by the Chief Commissioner.
 - (4). The holder of a permit shall camp only on such regular camping grounds as may have been set apart by the Forest authorities or in places specially pointed out to him by a Forest Officer.

(5). A permit may be cancelled at any time by order of the officer granting it or by the Conservator of the Circle. Any breach of the Forest Act or of any rule made under that Act if committed by the holder of the permit or any of his retainers or followers, shall render the permit liable to cancellation. Permits are liable to be declared invalid in regard to any particular forest in case of fire breaking out in any part of that forest.

(6). The holder of a permit is not exempted from liability under the Forest Act or any other law for anything done in contravention of such Act or law or for any damage caused by him, his retainers or followers.

IV. A permit issued under these Rules does not authorize the destruction of any kind of *Bird* other than the game and edible birds included in the following list:—

SYSTEMATIC NAME.	VERNACULAR NAME.
<i>Sand Grouse.</i>	
<i>Pterocles fasciatus</i>	... Bhut-titur. Dongur-kouri.
<i>exustus</i>	... Bhut-titur.
<i>Pea-fowl.</i>	
<i>Pavo cristatus</i>	... Mor Munjur.
<i>Jungle-fowl.</i>	
<i>Gallus ferrugineus</i>	... Jungly Murgh.
<i>Sonneratii</i>	... Do.
<i>Spur-fowl.</i>	
<i>Galloperdix spadiceus</i>	... Choti Jnngly Murghi.
<i>lunulatus</i>	... Do. do.
<i>Partridge.</i>	
<i>Francolinus vulgaris</i>	... Kala titur.
<i>pictus</i>	... Do.
<i>Ortyornis pondiceriana</i>	... Gora titur.
<i>Quail.</i>	
<i>Coturnix coromandelica</i>	... Chinuk.
<i>Bush Quil.</i>	
<i>Perdicula argoonda</i>	... Lawa.
<i>asiatica</i>	... Do.
<i>Microperdix blewitti</i>	... Sirsi Lawa.
<i>Bushard Quail.</i>	
<i>Turnix pugnax</i>	... Gundru.
<i>joudera</i>	... Do.
<i>Dussumieri</i>	... Tura Dubki.
<i>Bustard.</i>	
<i>Eupoditis Edwardsii</i>	... Hoom Tokdur.
<i>Lik-Florian.</i>	
<i>Sypheotides aurita</i>	... Tun Mor.
<i>Spurred-Goose.</i>	
<i>Sarkidiornis melanonotus</i>	... Nukta.
<i>Goose Teal.</i>	
<i>Nettapus conomandelianus</i>	... Girja.
<i>Whistling Teal.</i>	
<i>Dendrocygna arcuata</i>	... Silli.
<i>Grey Duck.</i>	
<i>Anas pœkilorhyncha</i>	... Garpal.
<i>Green Pigeon.</i>	
<i>Crocopus phœnicopterus</i>	... Harrial.
<i>chlorigaster</i>	... Do.

<i>Blue Rock Pigeon.</i>	
Columba intermedia	... Kabatur.
<i>Doves.</i>	
Turtur meena	... Kulla fachta.
„ oambayensis	... Tortru fachta.
„ suratensis	... Chitroka fachta.
„ risorius	... Dhor fachta.
„ senegalensis	... Serotl fachta.
Migratory marsh and water birds, such as duck, teal, snipe, &c., which do not breed in these Pro- vinces and visit them in the cold season only.	

V. With reference to clause (4) of Rule III, the destruction *during the close season*, of birds and animals named below, is prohibited. The close season is fixed as follows :—

For	<i>Close Season.</i>	
Sand-grouse	... 1st October to 31st May.	
Pea-fowl	... 1st March to 30th November.	
Jungle-fowl	... Do.	do.
Spur-fowl	... Do.	do.
Partridge	... 1st May to 30th November.	
Quail	... Do.	do.
Bush-Quail	... Do.	do.
Bustard Quail	... Do.	do.
Bustard	... Do.	do.
Lik-Florikan	... Do.	do.
Spurred-Goose	... 1st June to 30 November.	
Goose Teal	... Do.	do.
Whistling Teal	... Do.	do.
Grey Duck	... Do.	do.
Bison (cows)	... The whole year.	
Sambar (does)	... " "	
Chetnl („)	... " "	

VI. Nothing in these Rules shall prevent the disposal by auction sale, contract or otherwise of the shooting or fishing within any forest or part of a forest.

The 28th August 1891.

No. 6212.—Under Rule II, clause (1), of the Rules published by Notification No. 6211-A, dated the 27th August, the under-mentioned Government Forests are hereby and until further orders notified as closed against shooting, &c., except under permit granted in accordance with the aforesaid Rules :—

	Square miles.
Area of Government Forests in the Central Provinces	20,020
Area closed under this Notification except to permit-holders	8,130
Area available for shooting, &c., without permit	11,890

Note on Turpentine,

BY E. THURSTON, REPORTER ON ECONOMIC PRODUCTS.

American turpentine is imported into India from England ; French or other turpentine is not known in the Calcutta market.

2. The turpentine generally sold in the Calcutta market is impure. It is largely adulterated in England with kerosene oil, naphtha, benzoin, etc., and a further adulteration takes place in India. There is very little demand for pure unadulterated turpentine. Purchasers do not look so much for quality as for quantity. Merchants, therefore, keep only small quantities of pure turpentine, which they import direct from America, not through England.

3. The points of good turpentine are that it is as clear and transparent as glass ; that the odour is neither very strong nor bad ; that it dries quickly ; that, if spinkled on white paper, it dries at once leaving no marks behind ; and that, when handled, it forms a coating of very fine white dust on the hand. All these properties depend largely on the method of distillation. Any defect in the distillation lowers the quality of the oil. If any attempt is made to introduce the Indian product into the market, the greatest care should be taken in its distillation. Its resemblance to the oil already existing in the market is of far greater importance than its purity. In point of fact, its purity must be destroyed before it is put into the market, and its resemblance to the American oil is the main object which should be kept in view. The Calcutta Merchant from whom the present information was obtained, stated that, on one occasion, a sailor brought to Calcutta, a large quantity of pure turpentine which he offered for sale, but that he had great difficulty in disposing of it, because its odour was somewhat different from that of the oil usually sold in the market. It was at length purchased by Messrs. Dykes and Company, the coach-builders.

4. For internal administration medicinally, pure turpentine is required, but consumers generally buy it from shops for external application, and demand a large quantity for their half anna or anna. In such cases, they are supplied with stuff very largely adulterated with kerosene oil.

5. It is estimated that the annual consumption of turpentine in Calcutta is from ten to twenty thousand gallons.

6. Turpentine is shipped from America to England in tin canisters packed in wooden cases, but it is sent from England to India in iron drums tinned inside—, as contact with the iron would discolour the oil.

7. At the present time the wholesale price of turpentine ranges from Rs. 1-12 to Rs. 2-9 per gallon, in Calcutta.

8. In the London market the following are the present values of the various turpentines imported, as well as of rosin.

<i>American Turpentine</i>		25s. 3d. per cwt.
„ <i>Rosin (common)</i>		4s. 6d. „ „
* <i>French Turpentine</i>		none.
„ <i>Rosin</i>		„
<i>Russian Turpentine</i>		19s. and 19s. 6d. per cwt.
<i>American Turpentine.</i>		Average Values 1891.
Jan. 29 and 29-9	July	27s. 3d. and 28s. 9d.
Feb. 28-6 and 29-3	Aug.	27s. 3d. and 28s.
Mar. 28-9 and 29-3	Sept.	37s. 9d. and 28s. 6d.
April 29 and 30-3	Oct.	27s. and 28s.
May 29-3 and 30-3	Nov.	26s. and 26s. 9s.
June 28-8 and 29-3	Dec.	25s. 3d. and 26s.

<i>American Rosin.</i>			Average values, 1891.		
			<i>Common strained.</i>		
Jan.	Feb.	Mch.	April.	May.	June.
4-9	5	4-9	4-9	4-7½	4-6
July.	Aug.	Sept.	Oct.	Nov.	Dec.
4-0½	4-4½	4-3	4-6	5	5

9. The Dehra Turpentine is of very superior quality but cannot at present be sold at the highest price obtained for the best imported Turpentine. It can be sold at Rs. 1-8, to Rs. 1-14, per gallon, and, if it became established in the market, could probably be sold at Rs. 2, to Rs. 2-4 per gallon.

The questions then are :—

1. Will Rs. 2 to Rs. 2-4 per gallon pay ?
2. Can the Forest Department supply the Calcutta market ?

If so it would probably pay to send a large consignment to Calcutta, and sell it at first at a loss until the quantity of Turpentine imported is reduced. The price could then be raised.

* French Rosin or Turpentine seldom or never comes upon this Market now, so that there is no means of recording prices or averages.

We think it right to add that, in our opinion, the Dehra turpentine cannot aspire to conquer the Calcutta market which is too far away and requires too much ; all it can hope to do is to obtain a good sale in Upper India. Messrs. Lyell and Co. of Allahabad are advertising it at Rs. 4-8 per gallon ; if we could get Rs. 3 per gallon, all round, for Dehra turpentine, it would be worth while to build a factory and manufacture it and rosin (which fetches new Rs. 5-8 per maund) wholesale.

HON. ED.

II.—CORRESPONDENCE.

Range Officers in the Central Provinces.

SIR,

I understand that in other Provinces, Range Officers are allowed Travelling or horse allowance while on tour :—those in the Central Provinces are not allowed anything in this respect. Range Officers, to do their duties properly, have to be continually on the move and in all seasons. Some of them have to hire carts, ponies, &c., to carry their baggage; others (of the Forester's grade) cannot afford this and are in the humiliating position of taking their " belongings " on the same animal they ride. It cannot be said that this is a creditable state of affairs and the wonder is that some Conservator has not already remedied this real grievance on the part of a deserving class of officials.

It is certain that an able staff of Range Officers (whether Rangers or Foresters) is the *back-bone* of good forest administration; and it behoves Government to make the pay and position of these men equal to the responsibilities placed on them. In the Central Provinces, the majority of Range-charges are held by men of the Forester grade; therefore, in granting *travelling or horse allowance no distinction* should be made :—for the charges held by Foresters are, as a rule, as large and important as those held by men of the Ranger grade.

This subject is worthy the attention of the Inspector-General of Forests.

DELTA.

"The Mythology of Forest Fires."

SIR,

Several letters have appeared in the *Indian Forester* lately purporting to throw light upon the apparently mysterious origin of forest fires. Many of these are undoubtedly ingenious: and, if they have on occasions, warded off the rightful punishment which should have fallen on the conscious or unconscious incendiary or allayed the suspicions or wrath of a forest officer, they have done their duty. But, is it right that such myths should appear apparently as sober facts, in a journal advocating principles of advanced forestry, without at least calling for a footnote by the Editor,* or a suitable heading—such as, "Jokes

**Note.*—Our correspondent may see, printed on our cover, a para. to the effect that we do not hold ourselves responsible for the opinions expressed in papers other than Editorial. In cases of controversy, we must, as far as possible, leave our correspondents to fight for their opinions, or else we might find our Journal disappear for want of contributors. We are determined to do our best to exclude all acrimony and unpleasantness, but good humoured discussion, even with an occasional mistake,—cannot do much harm.

HON. ED.

on fires," "The Forester's explanation," and so on. Moreover, the matter appears to me to be assuming dangerous dimensions, for we shall soon have our trained Rangers and Foresters quoting the *Indian Forester* for their own ends; and, how can a poor un-Dehra-Dúned Forest officer dare to publicly disclaim such authority? We have all heard of the two gentle bamboos being rubbed together in a light breeze. That myth has, I believe, exploded. But, are our new origins of fires any wiser or more practical? To take a most widely accepted instance. I presume most forest officers would rigidly maintain and assert that forest fires can be started by throwing about a lighted cheroot. And yet, has any one ever succeeded? I most positively say—No! I do not ask for examples of instances that are supposed to have occurred, however good the evidence may be: but let any forest officer try the experiment, as an experiment, and I have little hesitation in saying that he will fail. No one will deny that this season of the year is most favourable for such experiments—yet I have been trying, and trying hard, but without success. Notwithstanding this, I have been positively assured by a most experienced forest officer in matters of fires, that he had actually started a fire, whilst engaged in plane-table work, by the cigar-ash accidentally dropping from his lighted cheroot! But this is nothing, compared to the rolliug stone. Will it be necessary to issue strict orders to every subordinate to remove all nails and iron-protectors from their boots?—and will it be dangerous to carry about a ferruled walking stick? And yet, has F. A. L., (I. F. Novr. '91), ever left his matches at home, and tried to satisfy his fumose longings by procuring sparks from a flint and stone, (a Gond's "chukmuk"), on dry grass, leaves, paper, and other materials available on that flinty hill-side? Let him try, and let us hope that his experiences will be recorded in the *Indian Forester*, not forgetting the exact time occupied in obtaining the desired result.

The fact is, the different manners in which a forest-fire can be started are very few, and very common place. A lighted match, (hence the real danger of smoking, hence the origin of all fires attributed to the innocent cheroot); the red-hot contents of a pipe, especially the red-hot bits of wood and dessicated rag placed on top of a "chilum," a camp-fire left burning or smouldering, sparks (*i.e.* red-hot carbon) from a railway engine; these with a very few variations, will about exhaust the list. I regret I cannot myself believe, or allow my subordinates to expect me to believe, in other mysterious origins, however clever, correct and ingenious the theory may be, as long as repeated practical experiments yield repeated failures.

C. P. TUSCAN.

30th April, 1892.

Occurrence of the Hamadryad in the North-West Himalaya.

SIR,

I write to ask you if you will be so kind as to identify and let me know the name of the snake of which I herewith enclose a description with measurements.

The other day, I shot a pair of these snakes within four hundred yards of each other.

L. K. MARTIN.

Measurement and colour of a poisonous Colubrine snake killed in the Palain Valley of the Garhwal district.

Total length	10' ft. 8½ in.
Tail	22½ in.
Greatest girth	8½ in.
Neck	5½ in.

The measurements are accurate, being taken immediately after the snake was killed and again after all muscular movement had stopped.

COLOUR OF UPPER SURFACE.—Head and back a dirty yellow grey with bands of bright yellow ¾ in. wide and 3 in. apart all down the body.

COLOUR OF UNDER SURFACE.—Throat a very pale salmon, changing to bright yellow along the belly and again changing to dirty black towards the lower extremity.

Loreal scale absent and poison fangs large and distinct.

Rises like a cobra showing a true hood which is perhaps a little longer but not quite so broad as that of the cobra. No. 2 could not be measured.

I have, on three previous occasions, killed, in the neighbourhood of Naini Tal, a snake of similar shape but smaller and of brighter colour:—between 8 feet and 9 feet long of a dull black, with brilliant bands of gold all down the body. The size and colour may perhaps vary with the locality.

I noticed a curious thing about one of those I shot at Naini Tal. It was trying to swallow another snake when I shot it, perhaps they prey on other snakes.

I have heard it called the king cobra. .

I was only able to measure one, the other got under some rocks after I shot it: but it was quite as long, if not longer, than the one measured.

There can be no doubt but that the snakes referred to by our correspondent, were the 'Hamadryad,' *Ophiophagus Elaps*, whose occurrence in the North-West Himalaya is interesting. See recent letters in the *Pioneer* on same subject.

HON. ED.

III.—OFFICIAL PAPERS & INTELLIGENCE.

Note on Lucerne Cultivation as practised at the Babu- garh Depôt, and later at Pooná Experimental Farm.

Lucerne (*Medicago sativa*) belongs to the Leguminosæ, and like many forage plants of that natural order, sends its long tap roots deep into favourable sub-soils, particularly those of a calcareous character. It is recognized as one of the most valuable fodder plants, resisting drought in an extraordinary way in those countries where it is grown without artificial watering. It shows its best results, however, under irrigation, and with a liberal application of suitable manure. In the neighbourhood of many military stations in India it is extensively cultivated and is sold at a high rate to form part of the daily ration of horses in hard condition. To milch cattle it can only be sparingly fed, ten pounds, the daily allowance for a horse, being also about the maximum quantity that can safely be fed to a milch cow. Its tendency to cause tympanitis is the danger that has to be guarded against in giving it to ruminants.

I believe there is a better method of cultivating lucerne than that ordinarily practised. The usual plan is to broadcast the seed on a clean well prepared seed-bed, 16 to 20 lbs. per acre. Beds about 10 feet square are formed by raising a small ridge round each compartment with a hand-rake after the seed is sown. This operation also serves to cover the seed. A through water gutter runs between each double line of beds. These water channels are therefore about 20 feet distant from each other. Their arrangement is regulated, however, by the evenness or otherwise of the field surface. Each compartment is flooded in turn, either by directing the water from an adjacent water channel or by temporarily breaking the divisional ridge between two beds, so that water can pass from the one to the other.

Lucerne planted in this manner will yield heavy cuts for two or at the most three years. Meantime the land becomes foul with deep-rooted grasses and other weeds which the cultivator is powerless to suppress, and on this account the lucerne fails when it ought to be in full vigour. In this respect the country method resembles lucerne cultivation in England, where the plant is grown in rows on the flat, 12 to 18 inches apart. By this process also the

crop is smothered after 3 or 4 years by a growth of twitch and weeds in spite of periodical horse-hoeing.

It is important that the crop when fully established should last, because the initial cost of laying it down, and subsequent outlays in manures are a like heavy. Seed alone costs Rs. 1-8-0 per lb. or Rs. 24 to Rs. 30 per acre. Regular watering, except in the rains, is important. The crop thrives best in a friable loam with a lime-stone subsoil.

On the Poona farm, a plan of raising lucerne has been adopted, which I first observed at Babugarh, near Meerut, and which I can unhesitatingly commend. The seed is sown on ridges which can be made 22 to 26 inches wide by an ordinary native plough.

In practice it will be found necessary to fashion the ridges afterwards into neat proportions with the hand-hoe. The slope of the surface of a field will indicate the direction in which the ridges should be drawn. Irrigation water must flow slowly along each furrow. If the inclination of a furrow is too great, soil and manure are swept to the lower levels of the field by the water gaining too much velocity.

For the seed (which is best sown by hand) a rather deep groove is made with the corner of a light hoe along the top of each ridge; the seed is carefully sown and is carefully covered and should not be buried more than $1\frac{1}{2}$ inch deep. The whole operation rounds and flattens the ridges and permits the seedlings to spring up in lines covering a width of 3 or 4 inches; crowding of the seedlings in a dense row is thus avoided. The importance of fine tilth is obvious, because the seeds are small. Frequent light waterings are required during the first fortnight, because the seedlings are delicate. They would probably wither, if exposed on the top of a ridge to a hot wind, unless sufficient moisture was within reach. This plan of sowing effects a saving of seed; 10 lbs. per acre is ample. In this connection, to avoid loss and waste of time, it is wise to test the germinating power of seed to be sown. This can conveniently be done by noting the percentage of seeds that strike when kept in moist flannel for two three days.

One object of sowing lucerne on ridges is to raise the stems of the plant out of contact with irrigation water. Under natural conditions, the plant requires very little surface moisture. Its great root development enables it to collect enough in the subsoil, and therefore when water floods the crop as well as the soil, as in the ordinary bed system, unhealthy conditions are induced, particularly in low-lying places.

The principal object aimed at in adopting the ridge and furrow system is to keep the field clean. The furrows can be weeded each time the crop is cut by using an ordinary bullock hoe or a scuffer. I have found the American "Planet Jr." hoe, which with extra parts costs Rs. 33, obtainable from Messrs. J. Fleming & Co., Bombay—the best possible implement for this purpose. It is

easily worked by two bullocks and can be drawn by a rope or chain attached to an ordinary neck yoke. If fitted with grubber tines in front, and an earthing up double mould board behind, it grubs up weeds, and earths up the ridges at an operation. It can be adjusted to any width of furrow over 18 inches. If manure is applied in the furrows every second cutting, as it ought to be, it can be, by means of this hoe, incorporated with the soil and placed directly in contact with the roots of the crop. Moreover, the furrows are left clean, so that water can flow properly. Four cwt. of bones per acre and fifteen tons of well rotted farm yard manure, applied some months before the seed is sown, is a good preparation. At least five tons per acre of farm yard manure, every second month thereafter with an occasional top dressing of bones, &c., or castor cake, are essential to continuous and increasing vigour of growth. With such treatment, a crop, on suitable land, will be thoroughly established six months after sowing, and yield thereafter 11 to 13 cuttings in a year. The Poona farm crop sown in June, 1891, yielded between that date and the following March, seven cuts. This last cutting, which was the heaviest, came to 6,034 lbs per acre. This is equivalent to over 32 tons per acre in a year. This quantity, at the current market rate of 100 lbs. per rupee, is worth approximately Rs 717. Crops grown on this system have lasted for six years and over, and there seems no reason to put any term to a crop which is well looked after.

If the lucerne crop is saved for seed, this should be done about the middle of the cold weather, water should be sparingly given for a month and withheld as the seed ripens. The object is to prevent a too succulent growth of stems and leaves, to encourage the formation of flowers and seed vessels, and to produce plump seed that has slowly matured.

Arabian grown seed is in some request in India.

The chemistry of lucerne shows it to be of high nutritive value.

Lucerne in flower gives the following analysis:—

Water	74
Albuminoids	4.5
Crude fibre	9.5
Carbo-hydrates	9.4
Ash	2

JAMES MOLLISON,

Superintendent of Farms, Bombay.

Poona, 9th April, 1892.

Wheat Prospects in India for the year.

We have received a number of official papers on this subject some of which are very interesting but we hardly think our readers will care to have them *in extenso*. In the *North Western Provinces* and *Oudh* there are this year 7,335 square miles of country under wheat crop, being a much less area than usual, and a crop of 70 per cent (or more familiarly 11·2 aunnæ) expected. The average price per maund of 82 lbs. is Rs. 2-9-5 or at the ports of Calcutta or Bombay Rs. 3-6-11 per maund. This, we are told, is equivalent to a net profit per maund in London of Rs. 3-7-8. In *Bombay*, the wheat area is reputed to be 4,093 square miles and the crop is expected to be variable, from 12 as. in *Gujarat* to 10 as. in *Sind*, 9 in the *Deccan District* and 2 only in the *Karnatic*. In the *Central Provinces* the area under wheat is said to be 6,573 square miles and the crop expected to be nearly 10 as. The *Punjab* reports shew the wheat area as 9,724 square miles and the crop as about an average of 12 as. all round. Those from *Berar* show the area as 1386 square miles and the crop about 12 as. Finally, the *Bengal* reports give 1860 square miles and a crop of only 7 as.

IV.—REVIEWS.

Annual Forest Administration

Reports of Bengal, Ajmere and the Andamans for 1890-91.

These have only just been received and are so late that we need not refer to them at great length. Of the *Bengal Government Review* we have long ago (Vol. XVII) given an account, though we had not then the Report itself to hand. Under a new system, all these Reports are kept back in the Press until everybody has had his say and then they are issued. It may be cheaper to the Government and more convenient for the Secretariats who get advance copies, but to outsiders it results in their issue at a time when nearly all interest in what they may contain has ceased.

The most noticeable feature of the *Bengal Report* is the Chapter on Establishment, which shews the results of the attempt to turn Bengali Baboos into useful Forest Subordinates. Of eight Bengalis sent to the Forest School for training in the past seven years, there are now practically only three left in the service, the others having all resigned or remained away on sick leave, while among the rest of the staff, prosecutions have been numerous. There is some reason to think that much of this result is due to the bad prospects held out, and the practice of putting

young Europeans or Eurasians into the Department over the heads of the natives, for we believe that Assam has secured better Bengali Officers by giving better prospects and promotion; but, at the same time, there can be little doubt but that Bengalis are not much more suited for Forest Work than they are for soldiering. Sir Charles Elliot thinks that a remedy may be found in encouraging athletic exercises in schools and colleges, and the Government of India very properly decide not to give up quite yet, but to await the results of improved prospects. We believe that, although of no use as combatants, Bengali gentlemen have done excellent work on frontier and other expeditions where quite as much hardship and malaria are to be met with as in the forests, in the Medical and Commissariat and Transport Departments, and we think that with better promotion and better prospects, better men will come forward and especially those from the Dacca and other Eastern Districts, where likely candidates may more probably be found than in those nearer the Presidency. Mr. E. P. Dansey has set to work with great energy in Bengal and we are sure the sad state of the staff which his report discloses will soon be changed into the efficiency which ought to come under such a Government as that of the Lower Provinces.

In the *Ajmere* Report the only noticeable feature is the strong disapproval which the Government of India have expressed of the policy which the Local Government has lately adopted in respect to grazing and fodder supply. The Ajmere Reserves, about the poorest of the forest areas of Northern India, were taken up, we believe, after considerable trouble, under the advice of Mr. A. O. Hume and Sir D. Brandis; and for a considerable time were very carefully protected, with the result of great improvement in growth, not only of trees but of fodder supply. Lately, as forcibly shewn by Mr. Hill in his special report, much of the good work done has been nullified by a too early re-opening to grazing and hence the remark of the Government of India, strong for them, that *except as regards the treatment of the fodder resources*, they consider the administration satisfactory. As everything in Ajmere depends on the grazing question, the importance of this remark cannot be underrated. We extract the following important expression of opinion from the Government of India Review.

“The time allowed for the cutting of grass within reserves was reduced from four months to one month in order to meet the expected scarcity of fodder throughout the country by throwing the state forests open to grazing. This action has involved a change not only of practice, but of policy also.

“From the year of the great famine, 1878-79, it had been the aim of the local administration to promote, on Government lands at any rate, the cutting of grass, and to reduce grazing within the narrowest limits; as the result of this continuous policy, the annual outturn of cut grass had steadily increased from 740,000 bundles in 1884-85 to 1,692,000 bundles in 1889-90.

‘ This fact was accepted as an indication that the people had begun to understand and appreciate the true advantages of a conservative treatment of the fodder-resources of the country, and some disappointment has therefore been felt that, in the year under review, it should have been thought advisable to abandon what is held to be the more economical method of reaping a grasscrop, in favour of grazing. The circumstance that general scarcity of fodder was expected would, if the policy hitherto advocated is sound, have justified a closer exclusion of cattle from the reserves, rather than their unrestricted admission while grass fit for the sickle was still on the ground. The outturn in cut-grass decreased from 1,692,092 to 304,000 bundles, or to 18 per cent. of last year’s yield.

‘ It is at the same time admitted that on forest pastures, especially where the arbori-vegetation consists to a great extent of scrub, there will always be found growing amongst thorns, a certain quantity of grass which cannot profitably be removed by hand, but will be searched for and grazed out by hungry cattle. With this fact in view the Governor General in Council has no objection to the proposal made in paragraph 4 of your letter No. 1227 S., dated the 13th June 1891, that such reserves should be thrown open to grazing in years of marked scarcity, provided that such action be not taken until after the removal of such fodder as can profitably be cut by hand.

‘ But His Excellency in Council cannot approve of the suggestion made by Colonel Biddulph, that all reserves, not specially selected for the production of timber and fuel, should be thrown open annually to grazing, subject only to a limitation of the number of cattle admissible to each block. The reserves do not appear to be either extensive or productive enough to justify a system of treatment which is held to be the least economical, and which would interrupt the progress of a policy which appears to the Government of India to be calculated to secure the fullest results.”

We should like to hear something about the system of planting which has given such favourable results. It is recorded that “the plants were put down in the ground in earthen pots (or gamlas) which protected them against the ravages of wild rats and the attacks of white ants, and also gave them the full benefit of the water given to them.” Planting trees in flower pots and then putting pot and all in the ground is a strange way of raising a forest. What do the roots do when they have filled the pot ?

The *Andamans*’ Report we have read with much interest, for though it contains very little of sylvicultural interest, there is evidence of a considerable development of the trade in timber from the Islands, which is gradually introducing new woods of value into the Home and Indian markets.

There are three chief markets for the Andamans timber, those of London, Calcutta and Madras. The woods sent to London were chiefly 'padouk' (*Pterocarpus indicus*) in squares and planks and the rate of sale, after allowing for exchange, &c., was apparently, on an average, Rs. 1-12 per cubic foot, but it is noticeable that Woolwich Arsenal took some of the timber at 4s. 6d. To Calcutta, the consignments consisted chiefly of 'Padouk', 'Lakuch' (*Artocarpus Lakoocha*), 'Toungpeing-ngè' (*Artocarpus Chaplasha*), 'Thitmin' (*Podocarpus latifolia*), Marble wood (*Diospyros Kurzii*), 'koko' (*Albizzia Lebbek*) and 'Gurjun' (*Dipterocarpus alatus*) and the price received came all round to a little over one rupee per cubic foot. The same result was obtained from the sales in Madras, to which place the same species were sent as well as some 'Pyinma' (*Lagerströmia hypoleuca*), 'Gangow' (*Mesua ferrea*), 'Thingun' (*Hopea odorata*) and 'Chuglam' (*Myristica Irya*), (we hope our identifications are correct—we insert them as it can hardly be expected that our readers at home or in other parts of India, will recognize what is meant by the Andamans names.) The extraction of this timber is carried on by Elephant dragging and a tramway, and its cost has been considerably reduced by the establishment of the latter.

Sylviculturally, the only noticeable matter is the discovery that by opening out the canopy round padouk standards, it is possible to secure a good advance growth.

The Government of India, acting on the recommendations of Mr. Hill's Report, have recommended the immediate commencement of a detailed examination of the padouk forests and the preparation of working plans for their management.

Annual Report of the Khandeish Experimental Farm for 1890-91.

There are only two things in this much reviewed Report which are likely to be of interest to our readers. One is the record that the produce of the 15 acres of Divi-Divi plantations amounted to 3½ tons which realized Rs 120 per ton in Europe, which Mr. Cappel, the Director of Agriculture, asserts to be equivalent to Rs. 80 per ton *net*. The other is the explanation of the proper method of making a 'stack silo' which we reproduce. The new system appears to have been tried at the suggestion of Mr. Ozanne and Dr. Voelcker.

"To make a stack silo :—Cart the freshly cut grass to a convenient spot and then throw it off on the ground without bed or

‘ bottom. Spread it and gradually shape it into a four-sided figure. ‘ The heap should be laid out 3 feet wider than is required, and ‘ trimmed back afterwards. Then when the heap is three or four ‘ feet high, walk two buffaloes or bullocks on its top round and ‘ round. Stacking should be done gradually, so that the mass may ‘ get time to heat. I have taken buffaloes on to the stack when it ‘ was over eight feet in height by making a slope of the green stuff. ‘ The bullocks may be kept on the stack at night, or, if removed, ‘ the stack should be weighted to press it down. When the required ‘ height is attained, the trimmings should be laid on to the top, ‘ thick branches of trees put on, and weighted with stones 2 feet ‘ deep. Stones should be of the size of a fist to a man’s head. ‘ Stones of larger size require more labour in loading and ‘ unloading.”

We can find nothing in the report to shew whereabouts exactly this farm is, though we gather that it is rather inaccessible. It is a pity that professional work like this could not have been reviewed by a professional, instead of by a series of more or less amateur civilians.

The Scrub Exterminator.

We have received one or two reports on experiments made on prickly pear with a mixture going under the above name, which has for some time been recommended as a convenient and efficient agent for destroying Scrub. The Mysore Gazette of the 11th February last, contains an account of several experiments conducted there under the supervision of the Inspector-General of Forests, Mysore; these appear to show that the Exterminator was more or less of a failure, the Prickly Pear stems operated on, though more or less dried up, retaining sufficient vitality to shoot up again and apparently requiring to be at once either buried or burnt after the application of the solution, to secure complete extermination. In the above experiments, solutions of different concentrations were used, varying from about 1 lb. of the chemical to $\frac{1}{2}$ a gallon of water to 1 lb. to 6 gallons of water. The price of the chemical alone, exclusive of the cost of pump, labour, &c., required for its diffusion, is about Rs. 60 per 100 lbs.

Several experiments have also been carried out in Madras, all of which tended to show that the Scrub Exterminator does not possess any material advantages over the ordinary methods of eradicating prickly pear and other plants, whilst it is more expensive; moreover the mixture is dangerous to use on account of its poisonous character, containing, as it does, arsenic, sulphur, alkali and alkaline salts. The solutions used in these experiments

varied from about 1 to 6 to 1 to 20, and the results, in most cases, showed that the effect of the chemical was only temporary, though in one experiment, a solution of 1 lb. in 20 gallons of water is reported to have been sufficient for destroying young clumps of prickly-pear. We notice that in the advertisement of the article, it is said to have been very successfully used to kill off pipal and banyan trees that had taken root in the walls of the buildings at the late King of Oudh's Palace in Garden Reach. If this is really the case, it ought to be very valuable, for we know of no other satisfactory means of getting rid of those terrible enemies of brick-work in this country.

V.—SHIKAR.

The Dehra Dun Fishing Association.

We have received from the Honorary Secretary a report for the year ending 31st December 1891; it contains Extracts from the earlier proceedings of the Association, and a clear exposé of the aims and objects of the members. With these we can thoroughly sympathize, and we trust that the endeavours of the Committee in urging on Government the necessity of legislation on the subject will be crowned with success.

At present the only waters which are preserved, are those in the Eastern Dún which are under Forest Rules; the other day a member of the association caught an 18 lb. Mahseer in these waters, an event which would be impossible at this time of the year in any other part of the Dún—this shews the good of preservation.

We understand that it is the intention of the Association to endeavour to introduce trout from England into one of the forest streams in the Eastern Dún, and we cordially wish them success. We shall watch this experiment with great interest.

VI.—EXTRACTS AND NOTES.

The Oak.

We see that Professor H. Marshall-Ward has just published a new and interesting book on the Oak, which is a short but complete account of the anatomy and physiology of the Oak as a forest tree from the earliest stage of its development from the acorn, through that of the seedling and sapling to the mature tree. Eight chapters are devoted to the description of the different organs and the growth, distribution and structure of the tissues in the various stages of development, including a somewhat complicated one on the course of the fibro-vascular bundles from the leaf to the stem. One chapter is devoted to a description of the timber of the Oak, its structure and technological peculiarities, one to the cultivation of the tree and the diseases and injuries to which it is subject, and a short concluding chapter gives the relationship of the Oaks and their distribution in space and time. The book contains numerous and excellent figures illustrative of the subject, which, however, lose some of their value from the reference letters being in many cases printed so small as to be illegible. Otherwise the book is extremely well got up and should prove of use to any one who is interested in forest botany. We are, however, a little inclined to doubt whether the treatise can be appropriately termed "a popular introduction to forest botany" as is set forth on the title page, as much of the subject matter would, we think, require a not inconsiderable previous knowledge of botany to be thoroughly understood and appreciated.

Goats in the Bombay Presidency.

One of the things not generally known is that in four Deccan Collectories—Poona, Nasik, Ahmednagar, and Sholapur—there are six hundred thousand goats, whose purpose is to supply the Bombay public with a large proportion of the "mutton" which it buys in the markets. A contemporary draws attention to the injury to agriculture which must inevitably follow from a plague of goats in the Deccan with its poor soil and scanty rainfall, the population of which is always a source of special anxiety to the Government. Goats are the most destructive of animals

where they abound all vegetation quickly disappears. They destroy any bush, and suffer no tree, no plant, to grow. They are not grass eaters, but in the dry season they nibble away the roots and destroy the pasture of the coming year. The desolation of the land around Aden is not wholly due to the want of rain; there are many gorges in which trees and bushes would grow were it not for the goats, which make short work of every twig. In Algiers, the goat pest proved so destructive that the administration issued an order that all in the affected districts should be tied up. The enforcement of this regulation had the desired effect, and the fertility of the territory, which was relapsing into desert, has been saved. St. Helena is rapidly becoming a mere rock, the woods which once clothed the hill-sides having for the most part disappeared. The changed conditions which are threatening the scanty population with ruin and extinction, date from the introduction of goats into the island. Any country overrun by goats will soon be in as hopeless a condition as the Australian pasturages which have been destroyed by the plague of rabbits.—(*Indian Agriculturist.*)

Match Manufacture in Japan.

Of all the industries which Japan has borrowed from abroad, that of match making has been the most successful. The first match factory was established in 1876, and by 1880 the demand for the foreign article had considerably declined, while Japanese matches were exported to the value of £58,532. There was a decline during the next few years, but in 1886 the industry recovered itself, and the export of matches in that year amounted to £63,000. Since then the trade has steadily increased, and though prices had considerably fallen meanwhile, the export in 1890 was worth nearly £236,000. The export trade is chiefly to Hong Kong (80 per cent.) and the Chinese Empire (17 per cent.) It is almost entirely in the hands of Chinese merchants, who place orders with the makers and arrange labels for the boxes. The operatives employed belong, as a rule, to a very poor class. The men are paid from 2d. to 7d., and the women from 1½d. to 4½d per day.—(*Timber Trades Journal.*)

We wonder that this industry has never yet been seriously taken up in India. It cannot be the wood that is wanting, for Himalayan fir wood can be delivered in the plains at 8 as. per cubic foot, or less. It must be the difficulty of getting the sulphur or the phosphorus or both.

HON. ED.

The Preservation of Logs.

A new method of impregnating logs with zinc chloride, in order to preserve them, is now in use in Austria, being known as the Pfister process. The timber is impregnated in the forest as soon as possible after it is felled. The zinc chloride solution has a specific gravity of 1.01 and is forced into the thick end of the log by a force pump. To this end, an iron disc of suitable diameter and furnished with a cutting rim is forced into the end of the log and secured by clamps. The time required for this preliminary work is three or four minutes for each log. After a pressure of two or three atmospheres has been maintained at the thick end of the log for a few minutes, the sap begins to exude at the opposite end and finally a weak solution of zinc chloride comes through, showing that the operation has been completed. About $2\frac{1}{2}$ gallons of the solution are required per cubic foot of timber treated. Though rapid, the process does not appear to distribute the solution so uniformly as other methods.—(*Ibid.*)

The Influence of Forests on Water Supply.

Does cultivation and protection of forests cause an increase in rainfall? The reply of Mr. Henry Gannett, as published in *Science*, does not tend to confirm the generally admitted opinion on this question: whilst the statistics collected by this scientist have the more value, in that they refer to extended tracts in which the conditions of the country and the climate, both before and after changes in cultural treatment, are perfectly well known.

His observations extend over—

I.—An area of prairie lands in the State of Iowa in the north of Missouri, in the south of Minnesota, Illinois, and partly in Indiana. This area, measuring about 163,000 square miles, was formerly entirely covered with grass, but during the last 30 years large portions of it have been afforested.

II.—The State of Ohio, with an area of about 58,000 square miles, formerly entirely covered with forests, of which at the present not one-tenth exists.

III.—An area of about 18,400 square miles situated in Massachusetts, Rhode Island, and Connecticut, which was densely wooded before its colonisation by Europeans. After the almost total destruction of these forests, about one-half of the area has, since 1860, been re-afforested.

If the removal of forests produces a decrease, and afforestation an increase in the rainfall, the result of observations extending over a long series of years should show in the first instance

an increase in the rainfall, in the second a decrease, and in the third a decrease up to 1860, and an increase after that date.

But the statistics collected by Mr. Gannett show that in these prairie lands an increase in the area under forest has not only not been followed by an increase in rainfall, but by an appreciable decrease. In the second instance, that of Ohio, a decrease in rainfall has indeed been proved, but this decrease is so insignificant that it cannot be seriously advanced as a conclusive proof of the unfavorable effect of disafforestation. The results of statistics collected in the third instance, that of Massachusetts, also do not tend to confirm in any way the generally accepted theory, for up to 1860 it is shown that there was an evident increase in the rainfall over this area, reaching a maximum of 2·8 inches annually.

Mr. Gannett also investigated the question as to whether the cultivation of land denuded of forest growth resulted in influencing the rainfall; but the result of these investigations proved that no increase or decrease had occurred.

In writing generally on the causes of atmospheric phenomena, we have replied to the often put question which forms the title of this article long before Mr. Gannett wrote on the subject. In this periodical some six years ago we said "that forests do not 'produce rain, but that they play the important part of storing 'it up.'"

As far as concerns Algeria, we have arranged the observations registered at various meteorological stations in the provinces of Oran and Constantine, and these observations, extending over a period of 25 years, refer to large areas covered with forest, adjacent to others which are entirely free from forest growth; and whilst the areas are not to be compared with those reported on by Mr. Gannett, yet the results of the observations are very conclusive.

The region where the rainfall observations have most interest for the Forester, is bounded on the north, between Bougri and Lalalle, by the Mediterranean, on the east and west by the valleys of Summam and Sezbose, and on the south by the high plateaux forming the water-shed between the sea coast and the desert of Sahara. This tract is in area about 47,000 square miles; and though no regular re-afforestation works are being carried out, yet the closure of large extents of forest and pasture land against the destructive action of the natives may almost be regarded as having a similar effect.

In spite, however, of these protective measures, many thousands of acres have from 1850 to 1875 been burnt over, and it is especially in these burnt areas, when compared with others successfully protected, that the rainfall statistics have the greatest significance.

These statistics show the following results:—

I.—That nearly the same amount of rain fell annually before and after removal of forest growth, and before and after re-afforestation.

II.—That totally different effects are produced by the annual rainfall before and after removal of forest growth, and before and after re-afforestation.

During the summer following the removal of forest growth the spring level begins to fall, and the following year most of the springs dry up.

In consequence, the water-courses cease to be permanent and become intermittent, being transformed, during actual rainfall, into impetuous torrents, which cease to flow during dry weather.

The valley of Oned-Guebli to the north of the province of Constantine, furnishes a remarkable instance of this.

This immense valley is divided into two portions by the river of the same name, and the western side includes the densest forests of this region, whilst the eastern is almost entirely denuded.

During eight years of topographical research in these mountains, we have invariably remarked that during the winter, when heavy rain falls persistently, often for weeks at a time, the floods in the water courses from the Western or wooded side rise slowly, and rarely overflow the banks, and even after tropical rain storms, which are frequent, the water remains clear.

On the eastern or denuded side, however, this is not the case. Scarcely has the rain commenced, when each small ravine becomes a torrent, which rolls down gravel, boulders and rocks, and overwhelms the neighbouring fields: whilst the muddy water passes rapidly on, arrested by no vegetation, conferring no benefit on the country it traverses,—to leave behind, on the cessation of rain, nothing but dry and rocky ravines.

There is, however, no need to expatiate on the disastrous action of rain in mountains and unwooded countries, it being too well-known.

At the same time, well-informed people have frequently an exaggerated idea of the value of mountain forests, attributing to them other virtues than those which they possess. The virtues they do possess are the power of storing up the rainfall, and thereby regulating the flow of water-courses and springs, and they are entitled to respect.

Our rainfall observations are extremely interesting in reference to forests which have been destroyed by fire; in such forests, the annual rainfall remaining unchanged, the springs dry up and the water-courses become dry ravines.

We need not be content with contemporaneous evidence; we can also bring valuable witness from the past to the truth of our assertions. About 10 miles to the west of the road from Constantine to Batna there is a horse-shoe shaped mountain range, with its convex towards the east. This range is named Djebel Anouda by the natives of the country. The inner slopes of this horseshoe were formerly thickly wooded; a fact proved by the

presence of stumps of oak trees. These stumps, deeply charred and rooted in soil thoroughly baked by the fire which destroyed the trees themselves, have hitherto resisted the decomposing effects of time. An enumeration of the stumps shows former growth of about 60 large trees per acre, and in the centre of this magnificent forest there are the remains, in hewn stone, of a gigantic tank, and issuing therefrom a broad aqueduct, traceable in its ruins for several miles. To-day the soil of Djebel Anouda is one of the most arid in Algeria; in former days, a strong spring existed, its water-supply stored and protected by a sturdy forest growth.

In concluding this short paper, we would like to add that, though the extent of the areas under our notice cannot compare with those observed by Mr. Gannett, on the other hand our rainfall stations are much closer to each other than those under Mr. Gannett's registration. Of 44 such stations erected by the Government of Algeria, the four which enclose the tract of Oned-Guebli have been most useful to us. It is this tract of country that the observations above recorded refer to, and these observations lead us to the conclusion that "the salutary influence of forests in storing atmospheric humidity is irrefutable; but to enable them to store this humidity, the atmosphere must first contain it.—L. PARQUET, in *Révue des Eaux et Forêts*."

Alaskan Forests.

The whole of the south-eastern portion of Alaska lying westerly of the coast-range of mountains is a dense forest.

One of the peculiarities of Alaska forest scenery that first impresses the observer, is the lack of variety which it presents. The whole forest area is composed of less than half-a-dozen species, and these, for the most part, are evergreen trees. The Hemlock, White Spruce, and Arbor-vitæ are the most prevalent—so prevalent that few would perceive there were anything else. The Hemlock Spruce to the common eye, would appear to be the same as our eastern species, *Abies canadensis*, but the botanist notices a distinction, and names it *Abies Mertensiana*.

English botanists endeavour to honour their Prince Albert in the same way, and in some of the catalogues of Pacific trees it figures as *Abies Albertiana*. The White Spruce, though resembling the Eastern, is also distinct, and called *Abies Sitchensis*, because the Russian botanist who first named it found the trees in the vicinity of the Russian settlement, Sitka. The Arbor-vitæ is there called Cedar, and is again different from the Arbor-vitæ of our Eastern States (*Thuja occidentalis*), by its paler green tint, and by the enormous size to which it grows. On this account, botanists

have named it *Thuja gigantea* (*Lobbii* of English gardens). The Douglas Spruce is found here and there, as is also the twisted Pine, *Pinus contorta*. There are said to be others here and there which I did not see. In a general way, we may say that the three first named make up the forests of Alaska. Among the deciduous trees the Oregon Birch (*Betula oregona*) and Alder (*Alnus viridis*), make fine trees, and often form dense woods on river bottoms, or along the wake of receding glaciers. Then there are a few strong-growing Willows, and these together make up practically the arborescent growth of Alaska. Now and then on the high ridges would be a solitary specimen of the Canoe Birch, Red Maple, and Elder-leaved Mountain Ash, indicating that east of the mountain ridge they might be found in quantity; and among the driftwood along streams, trunks of *Populus canadensis*, one of the Cottonwoods, would occasionally be seen, so that somewhere they may be found in some numbers.

Unfortunately, in the matter of timber, the Alaskan forests, as far as I saw them, are of little value. The trees grow so thickly together that, so far as the soil is concerned, they starve one another, and good logs would be very rare indeed. One can scarcely imagine from usual forest experience how closely these trees are packed together. I and my wife undertook to walk 4 miles by an Indian trail through one of those woods to a point where we might head off our vessel. So thick was the mass of vegetation on each side of us, the path being wide enough for one of us at a time to travel single file only, that we could not have seen a bear 10 feet away from us, and only for the rifle carried by the good Presbyterian missionary who piloted us, we would not have trusted ourselves amidst the jungle of foliage which made up these Alaskan forests.

One reason for the dense covering of the land with trees is the favourable conditions for seed germination and the apparent scarcity of seed-eating creatures. The warm temperature given off by the sea of Japan, which comes up south-westerly to break against the Alaska shores, meets the snowy-cold of the mountain peaks, condensing the moisture, so that the surface of ground—or, indeed, anything else—is never absolutely dry, and every seed that falls to the earth has a chance to sprout and grow.

TOTEMS.

In the old Indian village were White Spruces, 20 feet high growing out of the top of totem poles. These poles are themselves 30 or 40 feet high, and seem to have been selected from the largest trees. They are stripped of their bark, and have carved on them series of likenesses of creatures, real and imaginary, representing the genealogical descent of members of the tribe. It was a curious sight to see the White Spruces, like huge Christmas trees, growing from the flat tops of these poles. In some cases the roots from these living trees had split the poles in their descent to the earth,

into which the roots had, in some cases, so thoroughly penetrated, that, should the poles finally rot away, the trees would probably on these stilts of roots continue to grow on as trees high up in the atmosphere. Nothing but a climate continually saturated with moisture would permit of a seed sprouting, and the tree continuing to grow out of the top of a pole in this manner.— (*Gardener's Chronicle*).

VII.—TIMBER AND PRODUCE TRADE.

The Teak Market in the 1st Quarter of 1892.

Messrs. Denny, Mott, & Dickson report deliveries from the docks in London last month 1,838 loads; as against 1,666 for the corresponding month of last year.

The first three months of the year show:—Landed, 3,777 loads of teak in London Docks, as against 4,961 loads during the same period of last year; deliveries, 2,787 loads (of which only 623 loads Bangkok), delivered from the docks, as against 4,389 loads delivered during the same period of last year. The landed stocks in the docks show:—8,000 loads of logs, against 7,294 loads same period last year; 2,560 loads of planks, against 1,630 loads last year; 106 loads of blocks, against 36 loads last year.

The above figures exhibit a falling off of some 36 per cent. in the deliveries, and of some 24 per cent. in the supplies, as compared with the corresponding three months of last year; and however the shipments from Burmah and Siam may continue to fall off this year, through the scarcity of wood at the shipping ports, the stocks on this side will suffice to meet the present rate of demand for some time to come.

The almost entire suspension of foreign rolling-stock orders continues to stop our English railway coachbuilders from coming into the market for teak; whilst the demand for shipbuilding purposes has been weak, as is generally the case in the early months of the year.

On the whole, the conjunction of a bad demand with an undeniably short forward supply, seems to promise a quiet market with little room for any great fluctuation in price, provided shippers continue to recognise the fact that there is sufficient good timber on this side to leave them no excuse to attempt to

supplement their short shipments of good wood by those of inferior quality; as whilst it is always a mistake to press inferior teak on the European market, it is peculiarly so when consumption is falling away, and buyers consequently becoming increasingly fastidious as to quality and specification.

Messrs. Hoar & Brown report as follows:—

TEAK—		Timber.	Planks.	Blocks.	Total
		Loads.	Loads.	Loads.	Loads.
Stock, 1st March	Landing ...	8,810	2,587	103	11,500
Ditto	ditto ...	22	229	3	254
		<hr/>	<hr/>	<hr/>	<hr/>
		8,832	2,816	106	11,754
Deliveries	832	256	nil	1,088
		<hr/>	<hr/>	<hr/>	<hr/>
Stock, 31st March	..	8,000	2,560	106	10,666
				Timber.	Plants.
Deliveries for the quarter ending				Loads.	Loads.
31st March	1892		1,954	812
Ditto,	ditto ...	1891		3,590	869
Ditto,	ditto ...	1890		2,786	784

It will be observed that although the stock is somewhat reduced, the deliveries for the quarter compare very unfavourably with the same period of 1890 and 1891, showing that the demand still remains unsatisfactory. Now that the Admiralty have made their arrangements for the year's supplies, the market will no doubt assume a decisive tone and settle down more firmly without a recurrence of the fluctuations that have lately taken place. Although other business has been very quiet, the position points towards a firm market, and with short forward supplies, prices ought gradually to improve towards the summer months. The docks are still well stocked for present requirements, the timber being mostly of exceptionally good character, as nearly all the inferior shipments are now cleared away. Bangkok stocks are being offered broadcast at very low figures, and although the cargoes lately imported are of superior quality and condition to those of former times, yet they appear to command very little attention. The plank market continues dull and stocks excessive.—(*Timber Trades Journal*).

Churchill and Sim's Circular.

June, 4th 1892.

EAST INDIA TEAK.—The deliveries for the first five months of the year have been 4,269 loads, against 6,568 in 1891 and 6,409 in 1890, and for the month of May in the same years 901, 1,208, and 2,105 loads respectively. It will therefore be seen that a very material reduction has taken place in the trade in this wood in London, while seeing that the dock stocks are fully equal to the average, and that prices are moderate, is a very unsatisfactory position to explain. It can be accounted for only by general stagnation in ship-building as in other trades, and the fact that stock in this market has become relatively dearer than at other ports.

Rosewood—East India. There is a fair demand though prices are a little easier.

Ebony—East India. The demand remains very dull.

Price Current.

Indian Teak	per load	£9-10	to	£15
Cedar, Malabar	sup ft.	3d.	to	3½d.
Satinwood, East India	ton	£7	to	£12
Rosewood	" "	£7	to	£11
Ebony	" "	£8	to	£10

MARKET RATES FOR PRODUCTS.

Tropical Agriculturist, 1st June, 1892.

Cutch	per cwt	24s.	to	34s.
Croton seeds	"	15s.	to	20s.
Gum Kino	"	70s.	to	72s. 6d.
India Rubber, Assam	per lb.	1s. 6d.	to	2s. 2d.
" Rangoon	"	1s. 8d.	to	1s. 10d.
Myrabolams, Bombay	per cwt	9s. 3d.	to	10s. 6d.
" Jabulpore	"	8s. 6d.	to	9s.
" Godavari	"	9s. 3d.	to	10s. 3d.
Nux Vomica, good	"	9s.	to	10s. 6d.
Orchella	"	20s.	to	25s.
Red wood	per ton	£3.	to	£3-10s.
Sandal wood, logs	"	£35	to	£60
" chips	"	£9	to	£30
Sapan wood	"	£4	to	£7

VOL. XVIII]

[No. 8.

THE
INDIAN FORESTER ;
A MONTHLY MAGAZINE
OF
FORESTRY,
AGRICULTURE, SHIKAR & TRAVEL.

EDITED BY

J. S. GAMBLE, M.A., F. L. S.,

CONSERVATOR OF FORESTS, AND DIRECTOR OF THE
FOREST SCHOOL, DEHRA DUN.

AUGUST, 1892.

MUSSOORIE :

PRINTED BY THE MAFASILITE PRINTING WORKS
COMPANY, " LIMITED."

1892.

Contents.

NO. 3—AUGUST, 1892.

	Page.
I.—ORIGINAL ARTICLES AND TRANSLATIONS.—	
<i>Teak cultivation</i> , by W. Buurman (translated) ...	285
<i>Instruction in Forestry at Coopers Hill</i> , by W. R. Fisher ...	292
<i>Coorg and its timbers</i> , by G. H. Foster (No. 1) ...	297
<i>Useful maxims for tree-planting</i> (translated) ...	303
II.—CORRESPONDENCE.—	
<i>The seeding of bamboo</i> , letter from H. H. H. ...	304
<i>Fires caused by bamboo traction</i> , letter from E. D. ...	305
<i>Reproduction by extraction of stumps</i> , letter from C. F. E. ...	305
<i>A Departmental Blazer</i> , letters from "Velleda" and "Old Coopershillian" ...	306
<i>The appointment of Foresters</i> , letter from A. G. Hobart-Hampden ...	307
III.—OFFICIAL PAPERS AND INTELLIGENCE.	
<i>Rules for the study of Forestry by Officers on furlough</i> ...	310
<i>Report on the physique of Junior Forest Officers</i> ...	312
<i>The New Edition of the Code</i> ...	312
<i>Report of the Board of Control of the Forest School, Dehra Dún</i> ...	312
IV.—REVIEWS.	
<i>Annual Forest Administration Reports of the N.-W. P. and Oudh and Coorg for 1890-91.</i> ...	317
<i>Number of species in the Java Flora</i> ...	320
<i>Manilla Hemp</i> ...	320
V.—SHIKAR.—	
<i>A trip to Bara Bangahal</i> , by F. O. L. ...	321
VI.—EXTRACTS, NOTES AND QUERIES.—	
<i>Report on the Timber trade of Bosnia and the Herzegovina</i> ...	323
<i>A Burmese Axe-head Wood</i> ...	327
<i>How nutmegs are grown</i> ...	328
<i>The new head of the Woods and Forests Department at the Cape</i> ...	329
VII.—TIMBER AND PRODUCE TRADE.—	
<i>Selling rates of timber in the N.-W. P. on June 30th, 1892.</i> ...	330
<i>Market rates for produce</i> ...	331
VIII.—EXTRACTS FROM OFFICIAL GAZETTES.—	
SUPPLEMENTS.	
<i>Appendix series of the Indian Forester.</i>	
(2) <i>Podophyllum.</i>	

THE
INDIAN FORESTER.

Vo. XVIII.]

August, 1892.

[No. 8.

Teak Cultivation in Java.

*By W. Buurman, Forester.**

The duties of Foresters in Java and Madura are partly set forth in the Government Gazette of 1874, No. 110, Article 61.

Part 4 contains the short but important phrase, "They (the foresters) have the custody of the forests and their preservation according to forest science." Nothing more need be added, for every forester knows what these words imply. The forester has often to adapt his methods to local circumstances, he should not therefore, in the preservation and cultivation of teak, be bound by hard and fast instructions in regard to the technical part of his work.

It is my intention to call attention to the most practical methods for the preservation of teak forests; methods that are based on long experience.

There are many ways of regenerating the forests either by natural or artificial means:—Natural, by the spontaneous shedding of seed in the forests or by the springing up of stool shoots, Artificial, by planting up ground with seedlings procured from neighbouring forests or from nurseries.

Although the former is the less expensive, yet the results from it do not seem satisfactory, and so, without the interference of the State it will ever be, for the following reasons.

The teak forests are worked by denuding certain tracts of known extent of all valuable timber yearly. To secure good seasoned timber, the trees are girdled one or more years before felling, the girdling being done in the months of September and October before the rains commence; very soon after this, the trees shed their leaves and portions are exposed freely to light and air.

*Translation of a pamphlet 'DeDjaticultuur' kindly communicated by Herr Koorders, Conservator of Forests in Netherlands India, and translated by Dr. Slym of Moulmein, late Deputy Conservator of Forests, to whom our best acknowledgments are due.

In the beginning of the rains, the seed which had been shed and which lies on the ground, begins to germinate, while the seedlings which had sprung up the previous rains, grow and become stronger, but the undergrowth of shrubs and weeds also spring up and flourish to such an extent that they either suppress the young trees and seedlings, or in many instances entirely kill them off. A few saplings strong enough to struggle successfully against all these difficulties, are, in the dry weather, destroyed by jungle fires or often by the careless felling of trees by wood cutters.

The present system of working the teak forests being thus unfavourable to natural reproduction, the renewal of forests by natural means entirely, remains in these countries for ever an impossibility.

It may be urged that in giving contracts for the working of the forests, stipulations might be made with the contractors for planting up; but as this would impede their work, it would be sure to fail. On the other hand, with State exploitation of the forests, the forester becomes the exploiter; and, in the replanting and preservation of the forests, it can be left to his judgment as to what methods he had best follow.

Under present circumstances, the planting of teak is the only mode of renewing overworked and ruined portions of the teak forests.

Planting of teak has engaged the time and attention of foresters for many years. But it has not always been attended with success. The results, on the whole, with the exception of two districts, have been only partially successful.

As a rule, the planting of teak in old teak forest will be successful.

The abovementioned failures must have been the result of planting in over-worked parts of the forests. At least this may be one explanation of it. The favourable results which have attended my ten years of cultivation in the forest districts of Tegal-Pekalongan, as well as this year in the residency of Semarang may make a description of the work which showed such excellent results useful.

The ground for the planting of teak is prepared in September and October by clearing it from all weeds and shrubs, and by burning the old tree stumps so that they can throw out no fresh shoots.

After this, the ground is laid out in rows for the reception of the one year old seedlings. Then, as soon as the rains set in, the collection of young plants from the neighbouring forests is commenced. It is necessary that holes for the plants be dug previously at as small a cost as possible, for this it is enough that the ground should be opened only sufficiently to receive each plant. It should be mentioned that young plants for this purpose should not have more than four leaves and be strong and sound.

After the ground has been opened and the plants put in, the holes should be filled up by hand and pressed down. On marshy ground, the rows are raised so that there is sufficient drainage between them to keep the soil dry.

In this way the planting is soon finished and the clearing and preparing of the ground between the rows commenced. All planting should be concluded before the middle of January.

As soon as the young teak plants are in the ground the space between the rows should be cleared from all weeds, shrubs, and roots. The *débris* should be removed or better still, it may be buried in the ground and so serve as manure to a certain extent.

As soon as the ground is thus prepared, the planting of different kinds of fruits and vegetables between the rows of young teak plants is commenced. These fruits and vegetables are planted in rows leaving sufficient space for looking after the young teak and allowing access of air and light to the same. It is of the greatest importance to keep the fruit trees at such a distance from the young teak plants as to ensure the latter not being overshadowed by the former, a thing which is particularly likely to happen with the *Ketella pohon* (tapioca). A plant that has been suppressed during growth can be told at a glance, its trunk is weak and slender and the leaves lie in funnel shaped form against the trunk. Suppressed plants are always backward in growth, even after the cause has been removed.

As soon as the fruit trees and the young teak have reached a height of 20 centimetres, the earth is renewed.

The rows are thus kept up and are also carefully kept clear of all weeds till harvest time arrives.

After the harvest, the stalks left are pulled out and put down in rows by the sides of the teak plants which derive some little advantage therefrom.

Following this, the ground between the rows of the young teak plants is renewed and made ready for the planting of the different kinds of fruit trees, &c. This work takes till the month of October, by which time the young teak has become high enough to be left alone.

It can be understood that the cultivation of teak on this method by daily labour would be rather expensive ; therefore it is done by contract, the contractor receiving a certain sum and having the use of the ground between the rows of teak.

In this way the contractor having an interest in the cultivation, it follows that the better he looks after and tends his garden, the better is the harvest, and the young teak profits thereby. It is almost incredible how well teak succeeds, cultivated in this way and the method cannot be too strongly recommended.

Land with average soil can only be cultivated for one year ; no more planting can be done on the same ground and the contract is closed.

As soon as the yearly Government grant for this work has been sanctioned, contractors are sought for and verbal arrangements made with them.

The conditions entered into with the contractors are, the payment of a certain sum per acre by Government. This payment varies in different parts of the country. The contractor has to bring his own tools, also the fruit and vegetables he intends to plant between the teak rows.

And lastly he agrees to keep in good order the whole of the plantation till the teak cultivation is completed ; and further, if required by the forest officer, to stay another year.

The sum agreed on is paid in four instalments in the presence of witnesses, the first instalment being received by way of an advance in September or October. After the rows planted with teak are completed and the ground between the rows planted up with fruit and vegetables, the second instalment is paid.

The third instalment is only paid after the first harvest. All unsuccessful seedlings have to be replaced and all the plants to receive new earth, while the ground has to be planted up with vegetable and economic plants.

It is desirable that, for the second planting between the rows of the teak, those shrubs or herbaceous plants should only be used, which will not overshadow the young teak which, at that period, requires the warmth of the sun. Should all this work be accomplished within the time stated, then we can make certain that by the month of June the teak plants, having a strong development of leaves, will have attained at least the height of $1\frac{1}{2}$ metres and be strong enough to stand the dry weather during the following months.

Care should always be taken during this time that the ground is well looked after and that the young teak, as well as the trees planted between, receive fresh earth regularly.

Thus the plantation remains till October, when work between the rows begins, no renewed planting however being done.

The plantation is now cleared of all weeds, the ground is well opened up and the young plants receive fresh earth, and now the fourth and last instalment is paid.

The plantation can now take care of itself. It is possible that some undergrowth springs up but the young teak trees will soon overshadow this and in two years time, the sunlight will not be able to reach the ground.

I wish here to pause for a moment and consider the materials for planting, the method of planting, and the crops raised.

PLANTING MATERIALS.

These are the fallen seeds and the seedlings found in the forests which are utilized for the purpose. Should the tract of land to be brought under cultivation be too far distant from old teak forests, then nurseries must be established so as to procure young plants.

The seedlings should be ready for planting in the months of November and December, that is, in the beginning of the rains, procured either from the forests or from nurseries. The production of seedlings is assisted by setting fire, in the months of July and August, to the forests. The fallen seeds by this means get a good roasting whereby their germinating power is facilitated.

The heat chars the outer corky covering of the seed and the outer skin of the kernel is opened, thus causing a speedy germination.

The setting fire to the forests in the east monsoon solely for the above purpose, is seldom necessary, as they are usually set on fire at that time of the year by the neighbouring population.

In extraordinarily wet years the firing of the forests during the east monsoon becomes impossible, when it is advisable to collect large quantities of seed, to roast them and then to throw them broadcast over the ground in the forests.

The above described method of planting is simple and entails the least expense.

With regard to the favorable results obtained in Tegal and Pekalongan and since 1882 in Samarong, I have, in overworked forests, also in land near forests, not made use of any nurseries. Nevertheless, in some instances where cultivation was, as regards ruined lands, far from any forests, nurseries were necessary.

In such cases, the first thing is to procure good seed. Large and sound seed which, having well ripened on the tree, falls of itself, should be chosen.

The collection should take place in July and August. About September the seed should be put down near the ground intended for the nursery and covered up with a layer about $\frac{1}{2}$ a foot in thickness of *alang-alang* grass. This should be set on fire and when the grass is burnt out, to prevent the seed being entirely consumed, the mass should be stirred about till the ashes are cold.

The charred seed should then be wetted, and while wet, planted out in rows at a distance from seed to seed of $1\frac{1}{2}$ hands and put in to a depth of 3 inches.

The ground intended for the beds should be well dug up and worked to at least $1\frac{1}{2}$ feet in depth, and water daily poured briskly over it.

The plants begin to germinate from 4 to 6 weeks after sowing, and at the beginning of the rains are of a sufficient height for transplanting. The covering of the beds is not required longer than until such time as the seed germinates, when the young plant needs the warmth of the sun.

When the time to transplant the seedlings arrives the young plants are taken up, by the cultivators, with a clod of earth attached to them, out of the forests or nurseries, conveyed to their destined places and there examined one by one by an experienced hand. It has been found that very young seedlings thrive better than older ones, thus seedlings with soft herbaceous stems and

some four small leaves answer best. On the other hand seedlings with hard woody stems do not do at all well, always remaining stunted and a large percentage of them dying.

In removing the seedlings from the nurseries, care should be taken that their hair-like roots are not injured. Transplanting into the rows should not take place before 4 P. M. so that the young plants shall have the benefit of the rain, which usually falls in the evening, at once.

THE SPACING OF THE PLANTS.

With regard to the breadth of the rows in which the seedlings have to be put down, their distance from each other is determined by a consideration of the situation and quality of the ground and the strength of the seedlings procurable. When the ground is dry and of poor quality, it is advisable to cover it up as soon as possible from exposure by close planting. When the soil is rich, broad planting is advisable. The principle to work on is so to cultivate and work the ground that the plantation may be completed and closed in as short a time as possible.

As I remarked before, everything should be done to suppress the luxurious undergrowth in this tropical country by covering the ground in as short a time as possible. The rows between the teak, whether made broad or narrow, will not be of much use in this. The only efficient course is to constantly keep clearing the ground and to do this in the least expensive way. The planting of fruit trees as done by the contractors, serves this purpose.

In order to determine the distance between the rows, whether or not a sufficient number of contractors can be procured to work the plantation on the plan described above, is the first consideration.

It is generally understood that planters prefer the broad lines to the narrow ones and in this respect the interest of the planters and that of teak cultivation is the same! and therefore, it is a first condition that the distance between plants will not be so great as between the separate rows.

In the first year, attention has to be paid to the growth in height of the young trees and by close planting and constant working of the ground this can be obtained.

During the second year, the development of the branches begins, and in consequence of the closing up of the young forest, field labor in the plantation becomes impossible.

The space between the rows must be broad enough to allow the cultivators room for one year's cultivation, without their produce being interfered with or suppressed by the teak. The least room between the rows that can be allowed is 3 metres. Should this space be curtailed, there is danger of the cultivators removing the leaves of the young teak plants so as to admit light and air to the trees and vegetables they themselves are cultivating. This would, of course, interfere with the growth of the teak and to

prevent the practice, not only should the plantation be well watched, but sufficient room should be allowed the cultivators.

The spacing most recommended for planting teak is 1 by 3 metres that is, 1 metre between the plants, and 3 metres between the rows. In unfavourable soil, the space between the plants should be increased from $1\frac{1}{2}$ to 3 metres.

In the districts of Tegal and Pakalongan, I used various spacings; the 1 by 3 metres giving the best results.

No notice was taken of the Government order prescribing a spacing of 4 by 4 metres. Plantations made with this spacing are not easily completed and closed for as soon as they are left to themselves, the ground gets covered by *alang-alang* grass which catching fire and burning in the dry season, utterly destroys the young plants.

THE CHOICE OF CROPS.

It is understood that this connection between agriculture and forest conservancy has in view the attainment of a regular and cheap working of the land.

In the choice of the crops, attention should be paid to those which are most useful and afford most support to man.

Again, attention has also to be directed to the quality of the soil.

For the first sowing, between the rows, maize (djagoong) is recommended. It is sown immediately after the teak plants are in the ground. Following the maize, tobacco is put down, the time for which falls in February, and again in September.

The question however is that, considering the limited consumption of tobacco in the market, its importation from Europe and consequent easy procurability, will its cultivation on a grand scale be possible?

Tobacco to grow well requires a good soil, it cannot therefore be made use of in teak plantations made on poor soil. In the latter, the *Ketella pohon* (*Jatropha manihot*) is strongly recommended.

This plant thrives well in poor soils and has the advantage over others of spreading and affording shelter to the ground, while on harvesting, it necessitates some labour, as the roots have to be extracted and the ground thus thoroughly broken up. The *Ketella* has a tendency to form strong roots as well as a luxuriant leaf growth, which latter, indeed, if not seen to, will speedily interfere with the growth of the teak. For the latter reason, it is not advisable to plant the *Ketella* too close to the teak.

The *Lombox* and *Teron* are plants also recommended for planting in the rows. Both these plants thrive well in ordinary good soil and, with constant working of the ground, a good harvest is certain. Also the *Katjang-tjina* (*Arachis hypogaea*) is strongly recommended. It keeps weeds and all other undergrowth well down by its luxuriant leaf growth.

The Katjang should also be planted not too close to the teak, else there will be danger of its interference with the growth of the same. This plant, like the *Ketella*, has to have the ground well broken up for the removal of its fruits.

In conclusion, mention is made here of the Djarak (*Ricinus communis*). This plant is much cultivated by the natives owing to the fact of its requiring very little attention.

It is not, therefore, recommended for cultivation between the rows of teak.

Instruction in Forestry at Coopers Hill.

After reading, in the March number of the *Indian Forester*, the Editor's paper on the advantage of practical work in forestry education, I regretted that distance compelled me to allow several numbers to appear, before I could remove the impression it conveys to readers of the *Indian Forester*, that practical training is not amply afforded to the forest students at Coopers Hill.

The object of my previous paper *was to explain why a term of preliminary practical work in Germany is not necessary for our students before the commencement of their course at Coopers Hill, and Mr. Gamble agrees in this, but thinks I wish to reduce practice to mere tours in the forests, all crowded into our third year; he also assumes the possibility of our men coming out to India, "*stuffed with theory, but incapable of replanting a bare hill-side, or of thinning an overcrowded compartment.*" He wishes them "*to learn practically how to thin forests, to make nurseries, to plant, prune and tend trees,*" which can, as he says, be very well done in England, but he is afraid that such absolutely necessary instruction is neglected at Coopers Hill.

It is unaccountable how he failed to notice my statement; "*that every forest school should have an area available where practical instruction may be afforded in planting, sowing, thinning and other silvicultural operations, also in measuring trees and in estimating the contents of woods.*" Why should we pay £300 a year for 800 acres of forest, if we don't set our students to work there, as well as in our large forest nursery within the College grounds?

**Indian Forester*, Vol. XVIII, January No, p. 12.

During our first year's course, exclusive of botanical excursions, one afternoon every week in the October and Lent terms, is devoted to out-door forest works ; observation of the mode of growth of trees in Windsor forest, or, in its proper season, nursery work or planting, in which every first year's student takes his share : during the summer term, besides the above operations, one whole day every week is employed in fire conservancy, or in making thinnings in our own forests or in visiting the neighbouring forests of High Wickham, Esher, Epping, &c, during the fellings, when they are most interesting to study.

Mr. Gamble, curiously enough, assumes that our students only visit the forests I have described, in their third year, when there would be danger of showing them too much at once, though I distinctly stated that they see the Normandy forests in their first year, while our second year's men work in the Windsor forest at thinning compartments of Scotch pine, and at forest estimation, description of compartments and preparing working plans. They will also visit the New Forest, or the forest of Dean at the end of their second year. Our third year's men visit the German forests with Sir Dietrich Brandis, principally to see applications, on a large scale, of their training at Coopers Hill ; they also prepare a working plan in a selected German forest besides working with their own hands in the Schwartzwald, at thinnings, charcoal making and sliding timber down hill-sides with ropes and levers, and at other forest operations.

How then, can Mr. Gamble have imagined that our men spent their first two years in theoretical studies, and only enter the forests in their third year, and that we show them too much at once, and do not ground them in practical work. My contention is for practical work and instruction work *pari passu* with theoretical instruction, and with a professor at hand to explain matters.

The necessity for such a method of instruction was soon discovered at Dehra Dun ; before 1885, the Deputy Director of that school was in charge of a forest division and only taught during the rainy season, and the students were distributed amongst the forest divisions of the N. W-Provinces and Oudh to learn practical work. As a necessary consequence, the divisional officers set them to do whatever was most urgent at the time, and they had little leisure to explain matters to the students, so that the latter kept on doing the same thing over and over again, and made little progress in a general knowledge of forestry. In fact, under this method, for them to see everything of interest in the forests of the Province, much more time would have been required than the 12 months available in two working seasons. Dr. Schlich then found it necessary to set free the Deputy Director and Instructor at the School from all executive forest work, so as to enable them to teach silviculture, and road making, &c, in the forest. Is it likely that he would now wish the Coopers Hill students to learn forestry merely in the class-room ?

Mr. Gamble refers to certain obsolete methods of instruction or medical and engineering students, in which they learned

practice first and theory afterwards. This has been entirely abandoned for the medical profession as the *practical* doctors killed off too many of their patients. As regards engineering, the famous French *École Polytechnique*, the Royal Naval College at Greenwich, as well as the Royal Engineering College at Coopers Hill, are all highly successful instances of scientific education combined with technical training. Numbers of men from all these colleges, besides holding most important posts under Government, have accepted lucrative appointments and partnerships in private engineering firms, which shows how highly such a training is esteemed now-a-days. George Stevenson and Brunel succeeded without good theoretical training, because they had immensely strong intellects, and were without competitors of any great calibre, and they paid for the best mathematical ability available to work out their calculations, which they could not do themselves. Times have changed, and any one now following such a plan would waste his strength on drudgery, and hardly ever rise to any eminence.

A good scientific education is also now essential for forest officers, and with the greatest possible respect for Scotch* foresters who have been tried in India, and for Mr. Thiselton Dyer's gardeners, I contend that our *corps d'élite* of the Indian Imperial Forest Service should be trained on a different plan to the rough and ready practical one; if, as Mr. Gamble says, "*much of the best work of the Forest Department in India has been done by men who have never heard a theoretical lecture nor entered a German Forest,*" why does he not persuade Government to put an end to the forestry instruction at Coopers Hill and Dehra Doon, and go back to the more economical state of things which existed thirty years ago? The fact is, however, that a want of proper initial theoretical training can rarely be supplemented afterwards by study, as the work of administering the forests of India generally makes too great demands on the time of forest officers, and such training is best absorbed by the young, and not by men who have spent years of their life at routine work.

During my visit to the Nancy Forest School, last December, the Director expressed surprise and regret that so little has been done in the way of original papers on Indian forestry, by the Englishmen, who were trained at Nancy for twenty years. This, I believe to be chiefly due to want of leisure, but some of our clever men may also think it wiser to reserve their energies for the routine of administrative work. Our countrymen are only too ready to take to the practical side of things, and to neglect scientific research, and the spur of the Editor of the *Indian Forester* might be used with advantage to counteract this tendency, not to confirm it.

*The canny Scotch finding that mere practice is not sufficient, have now got a Professor of Forestry to teach them.

Mr. Gamble speaks of *balivage*, *estimation*, *recolement*, and surveying *coupes*, as the extent of the practical work he did at Haguenan. Do all readers of the *Indian Forester* understand these terms? They mean marking trees for felling, estimating their volume, and counting up the stumps of felled trees; whilst surveying a *coupe*, or felling, does not differ materially from surveying any other area. There is a good deal of monotony about *balivage*, *estimation* and *recolement*, when steadily followed nearly every day for eight months in the forests of a single district. Mr. Gamble does not say a word about making nurseries, planting, pruning and tending trees at Haguenan. I was not made to do any of those latter operations there, and got heartily sick of *balivage* and *recolement*, when the war of 1870 curtailed our stay at Haguenan by two out of the intended eight months. Monsieur Clement de Grandré, of whose instruction Mr. Gamble speaks so highly and with whom I lived, and who was a most excellent and indefatigable forester, was taught at Nancy, on the plan of theory first and practice afterwards, and I wonder how many of Mr. Gamble's fellow students who joined Nancy fresh from the Lycées, have turned out bad foresters, owing to the supposed *vicious* system of instruction they were subjected to. The French Government has now even gone further than formerly in theoretical instruction, no student comes to Nancy without having first passed through a two year's course at the *Ecole Agronomique*, and competed successfully against about 200 students of that school for admission to Nancy, as a state forest student. As for the bias in favour of any particular system, if men are first taught by practical foresters, instead of by professors, I maintain that no comparison of systems is necessary to induce such bias; it is sufficient that a student finds a hardworking, intelligent forest officer carrying out a particular system, with excellent results, for him to wish to apply the system elsewhere, even under circumstances where it is not applicable. The French state forester's rage for converting coppice with standards into high forest, and against the selection system, artificial planting and low rotations with a view to high interest on capital, have prejudiced many an Indian Forest Officer against systems which give excellent results in certain European localities and are frequently applicable in India.

Sir Dietrich Brandis has kindly written to me about my paper from a different point of view to Mr. Gamble's. He writes, "*As for German students, I prefer the Prussian system, but as regards English students, the case is much stronger, not a single German student, who takes to forestry at Giessen, Tubingen, Karlsruhe, &c., is ignorant of the great essential features of forest management. With them, forestry is a matter of course, they believe in the necessity of methodical forest management, because they have been accustomed to it all their life. English lads will not take kindly to forestry, as a profession, unless*

they have realised what forest management on a large scale is." Now that our students go regularly in their first year to the Norman forests, there can be no doubt that they do appreciate forestry on a large scale and the knowledge they acquire of the treatment of these forests, gives us a firm basis to work upon in our subsequent lectures.

With reference to forestry instruction at Dehra, I am glad to see that silviculture has returned to its former place in the programme, which was altered in 1887 against the wish of the Director, by the Forest Conference. Previously to that year, silviculture was taught in the forest, after the necessary preliminary instruction in botany and other auxiliary sciences. That practical forest work was thoroughly taught at Dehra, before 1889, may be gathered from all the early school reports, and from a review in the March number of the *Indian Forester* for 1889, written by a distinguished Indian Forest officer, who praises, "*the thoroughly practical way in which forestry was taught,*" and states, obviously after a personal experience of the lectures, "*that Mr. Fernandez' forestry instruction was of a character to stop the learning of lessons by rote and to make the students think, instead of merely reproducing the teacher's work.*" Instruction at Dehra has always been largely of a practical nature, the students spending eleven months in the forest during their course, and it is satisfactory to hear that this continues to be the case. Whether too much theory may not be crowded into the eight months of two rainy seasons, is another question for the consideration of the Controlling Board of the Dehra Dún Forest School.

As this letter has passed through my hands on its way to Press, I feel obliged to explain that Mr. Fisher has misunderstood a considerable part of what I wrote in the March number.

What I then wrote was not intended to have any special reference to Coopers Hill, but to discuss the impression which his paper in the January number had given me of his opinion on the *general* question of 'theory' ~~versus~~ 'practice.' If he or anyone else has taken what I wrote to refer to the Coopers Hill College, I can only regret that I wrote so clumsily as not to make it quite clear that such reference was not intended. I have naturally a very fair knowledge of what is done at Coopers Hill and my writing was intended to be purely general. As regards Dehra Dún, I quite fail to see how my words could be taken as a comment on the past, and they most emphatically were not intended to be anything of the kind. I have far too much to do with the present to trouble myself very much about the past and I can only regret that anybody should have imagined otherwise.

I can only further regret that my friend Mr. Fisher should have made such a series of inferences from what I wrote. I shall not attempt to reply to them, but allow, as Editor, the present letter to close the discussion.

J. S. GAMBLE,
HON. ED.

Coorg and its Timbers.

Perhaps before commencing a description of the more valuable timber trees of Coorg, a short account of its locality and topography will be interesting. A good many of my readers, doubtless, have somewhat hazy ideas of where Coorg is. I know when I was ordered down here, I had to study the map of India before I was certain where I was going. Coorg is a triangular piece of country in the S. W. corner of Mysore. It is bounded on the north and east by that State, on the south and partly on the west by Malabar, the north western corner being touched by South Canara.

Its topography is easily described. There is a narrow flat strip of land along the eastern edge widening in the S. E. corner to about 7 miles broad. This strip is cut in two about two thirds of the length of the border from the north by a spur of the ghats which runs out into the Mysore country at Siddeshwara. The rest of Coorg is on the western ghats, the highest point in the Province being Tadiandamol, a noble hill forming part of a high range running parallel with the South Eastern border. The height of Tadiandamol is 5,729 feet. The scenery in Coorg is very beautiful. To the lover of the hills, every gorge, every ridge presents some new pleasure to the eye, while in the east and north east, the cultivated plain, broken by park-like groves and wellavenued roads, yields a milder scene. Again, in the depths of the forests in the South-East, yet a third variety of beauty is to be found. Here the giant stems are mixed with dense leafy undergrowth and the rigidity of the forest tree, modified by the graceful wave of the bamboo. Every road through these forests presents vistas of great beauty and an artist would revel in Coorg for he would find a picture to hand wherever he went.

The climate of Coorg is so totally different to that of the plains that it is not easy to compare it. Once the rain falls in April, it is, to one who has experienced the hot weather in the N. W. P. and Oudh and the Central Provinces, delightful. But there is the absence of the invigorating cold weather of those parts of India, which is a serious drawback to Coorg. Again, the very heavy rainfall in the monsoon makes the provincial headquarters anything but a desirable residence. Along the Eastern border the rainfall is much less, and not least among the noticeable points of this province is the extraordinary variation in the rainfall on the western and the eastern borders. This difference is as great as 200 inches.

The tree vegetation of Coorg is sharply divided into deciduous and evergreen. The two classes intermix along the eastern slopes of the ghats but by far the greater area of Coorg is covered with what may be practically called evergreen forest. For even

the deciduous trees which are to be found among them nearly all over the district seem to alter their habit and so arrange their leaf-fall as to ever present a bare appearance. This is very noticeable in the figs. On the east, in the month of March and in the first part of April, the forest is much in the same condition as it is in the Central Provinces at the same time of the year, but the middle of April brings with it heavy showers of rain and in a few days the forest is green again, having been bare for but a short time. Indeed the leafing is so varied with different trees that the forest is at no time absolutely devoid of leaf.

The best timbers in the deciduous forests are.

- Teak (*Tectona grandis*).
- Honné (*Pterocarpus Marsupium*).
- Bíté (*Dalbergia latifolia*).
- Mattí (*Terminalia tomentosa*).
- Nandí (*Lagerstrœmia microcarpa*).
- Arsautega (*Adina cordifolia*).
- Kadiála (*Stephegyne parviflora*).
- Ulwé (*Terminalia paniculata*).
- Udé (*Bignonia xylocarpa*).
- Jálá (*Shorea laccifera*).
- Nogá (*Cedrela Toona*).
- Bilwára (*Albizzia odoratissima*).

Teak is, of course, the most valuable. It is found in the largest size and quantity in the south east forest.—Nalkeri and Hotgat. Here it attains a great size and there are giants in these forests which owe their escape from the axe principally to their being too large for removal. These trees are, however, comparatively short in the bole and do not exhibit a really fine growth. Many of them are double stemmed, most are hollow and the younger trees are very crooked and ill grown. Teak is plentiful all along the eastern border but gradually decreases in size as we go north. Thus, Anekadu and Atlur Forests, at about the centre of the eastern edge, contain trees of moderate size, the greater number hollow and almost all badly grown, while Malambi, India and the other north eastern forests, though containing much teak, possess no large trees, the growth being mostly large poles and third class trees.

Teak practically disappears in the centre of the Province from below Kirajpet to the north-west corner of Mysore; and from the foot of the rise to Mercara, about seven miles from the eastern border, to well over to the west of that town, no teak is to be found, but it re-appears on the western slopes of the ghats overlooking South Canara where there is a fine teak forest, and again on the Cannanore Road. Here I one day came across a butt end of a tree which had first been dragged out by elephants. As I stood close to it, I could not see over it and I am 5 feet 10-

inches high in bare feet. There are probably some giants still existing in the more inaccessible gorges and ravines in these slopes of the ghats.

The teak of Coorg is a good wood but very liable to heart-shake in felling. It would be worth while experimenting in girdling. The only statistics of yield that are available, comprise the export to our depôts on the east of the district and in Mysore. I find that during the past five years, the following quantities have been brought to the depôt.

1887-88	29,576	cubic feet.
1888-89	40,138	do.
1889-90	30,400	do.
1890-91	31,890	do.
1891-92	21,585	do.

The fall in the quantity brought to the depôt in 1890-91 is due to fellings having been stopped while the stock in the forest was being valued. There was reason to believe that much of the timber shown on our books had been burnt or lost. The natural reproduction of teak in Coorg is not good, and has to be supplemented by other means of growing trees. These are three in number; regular plantations, planting out in the forest and kumri. Dibbling seed does not answer, the coarse grass in the south eastern forest killing the young plants.

The only regular plantations which are extended are those at Kutampollé on the Cannanore road at the foot of the ghats. All others further north and east are practically failures and any continuation of the work there has been abandoned. The Kuttampollé plantations now cover acres. The system has been to clear, fell the area intended to be planted and supply it from a nursery. In my opinion the results are not commensurate with the expenditure. Pure teak plantations were long ago abandoned in the Central Provinces and judging from the appearance of the Kutampollé plantations, I should say that pure teak does not answer here, even though the heavy rainfall and the great heat assist the growth. In November last when the surrounding forest was a wealth of leaves, those of the teak in the plantations had been destroyed by an insect. *Every leaf*, without a single exception, was a beautiful net work of fibres with the cellular tissue eaten out. The leaves had turned brown and from the top of the hill the planted areas were clearly noticeable, they being brown patches in the midst of the surrounding green, their edges being sharply defined. The growth of the trees, too, is not satisfactory. The stems have a sickly appearance, and I cannot but think that pure teak is a mistake. However, the usual extension is being made this year, but in addition I am planting up a large area by clearing lines in the standing forest. These young plants will require looking after the first two years of their life and care must be taken that they are not suppressed by surrounding vegetation but the method is a very much cheaper one and it will, I believe.

prove a more efficacious way of stocking a forest. This second system is this year being tried in Nalkeri and Dubare on the eastern border. Our works have been much crippled owing to the failure of the crop of teak seed. But next year, it is hoped, will see this method of stocking forests more fully carried out.

The third way of introducing teak is kumri. It is too well known to require description; as yet there is only one kumri in Coorg. This is on the eastern border a little below the middle of the same. It has proved another failure. Ten acres were given over to Kurumbers who sowed "raghi" and at the same time put young teak out. Owing to want of water the seeds were not put down in the nursery till so late in the season that when it came to transplanting them they were still but little tiny plants. The cessation of the monsoon caused them to droop and when I last visited the field, after the April showers had caused the surrounding forest to burst into green, there were only a few miserable little strugglers against adverse circumstances of the thousands which had been planted. A small extension is being tried during the current year but its failure is, I think, certain. The introduction of teak by kumri in the ghat forests had long been contemplated. Kumri is much practised there but no attempt had been made to utilise it for the planting of teak. However, this year Mr. Meiklejohn, the Commissioner of Coorg and myself, on a tour in the western ghats made a determined effort to induce some of regular kumri ryots to take to planting teak. Every one who has had to introduce a novelty into India knows how difficult it is to get the ryot to take to anything which his grandfather had not done before him. The people in the ghat are very wild and uncivilised and it was only after much persuasion we induced them to agree to try one acre each. It was somewhat late in the season but I hurried up the supply of seed and everything promised a real start when all our efforts were rendered of naught by the pigheadedness of a Ranger and the matter will have to stand over till next year. It still remains to be seen whether this system is a success or otherwise.

In a country so fully stocked with forest as Coorg, it is to teak and honné on the east and teak and one or two other trees on the south and west that we must look for revenue and the Department should leave no effort to increase the growing stock of this tree. The gradual, and by no means slow, exhaustion of the Mysore forests, will render money spent on the propagation of teak well laid out; and teak still maintains, and will maintain, its pre-eminence among the timber trees of India.

The next valuable wood in the deciduous forests is honné (*Pterocarpus Marsupium*). This is found in the eastern forests and extends considerably more to the west than does teak. It is to be seen almost up to Mercara itself, but is rare, if it exists at all, on the western ghats. Though its market price is considerably lower than that of teak, it is in great demand, being much used for building purposes. The D. P. W. in Coorg now use nothing

else and I never find decently sound honné lie on my hands in my depôts. It grows to a considerable height but rarely, if ever, attains the enormous girth that teak does. Its reproduction is somewhat unsatisfactory and small poles of honné in most of our forests are conspicuous by their absence. It coppices poorly but as it is a very large seeder, it will doubtless assert itself where we can keep out fires.

There is no need for me to enlarge on the excellent quality of its wood. Strong, elastic and durable for certain purposes such as beams carrying heavy weights, it is really more valuable than teak; while its kino preserves it from damp and insects. The quantities brought to depôt during the past five years are as follows. Its price varies very much, but at present there is a great demand and I have sold honné for one rupee a foot but its usual price is ten annas.

1887-88	20,819	cubic feet.
1888-89	29,967	do.
1889-90	15,396	do.
1890-91	15,382	do.

Fellings of honné were stopped in the year 1890-91 for the same cause as given under "Teak," But the stock in the forest was sufficient to supply the depôts with a fair quantity.

The next on our list is Bité or Blackwood. Though this wood is used principally for furniture, there is a very large demand for it. It is so eminently ornamental that it is used for many purposes for which it would not be available where it was not so plentiful. A graceful tree, it grows to much the same size as honné and is the constant companion of the latter in the forests, in the east and east centre of Coorg. Its habitat extends further into the evergreen forests than even honné. Its very great weight is a factor against its transport but there is a compensating fact in small logs being as utilisable as large ones. Just at present there is a heavy demand for Blackwood and all stock either has been sold or is likely to be disposed of. Its reproduction is good. Its habit of throwing up suckers and coppice shoots gives it a great advantage over honné and if I can only enforce the system of felling flush with the ground, I hope to see our forests well stocked with blackwood.

Honné and Bité are much liked by coffee planters for shade, whereas teak is their *bête noir*.

The quantities brought to depôt are given below. The price of blackwood is generally from an anna to two annas per foot higher than honné.

1887-88	}	not shown separately from other woods in the returns.		
1888-89				
1889-90				
1890-91	1,458 cubic feet.
1891-92	3,754 do.

With Blackwood ends the list of deciduous trees which at present fetch anything like decent prices in the market in Coorg. **Matti** (*Terminalia tomentosa*) is, in log only, used by cartmakers for the pole and body of carts. As a pole it is very popular in housebuilding. It is interesting to note the different uses to which the same tree is put in different parts of India and how the one tree is thought highly of in one place and is valueless in another. This very Matti is never used, as far as I know, in the C. P. in cart building and the immature trees are considered so untrustworthy for building purposes that they are never used unless felled at a certain time in the year. There, and all over the Mahratta country, the "Dindiga" of Coorg, the "Dhaora" of the C. P. and Khandesh (*Anogeissus latifolia*) is the wood *par excellence* for cart axles, and, where procurable the Tinsa, Tinnas or Tewas (*Ougeinia dalbergioides*) for cart poles.

Though there seems an undefined idea that Matti takes the *pas* in woods, still I am of opinion that the latter is really a more valuable tree all round than the former. It grows well and straight, is not so liable to unsoundness as other trees, reproduces itself strongly and sustains adverse surroundings better than most trees. Its wood is easily worked and, provided it is not exposed to much damp, turns out excellently. In furniture it is eminently useful and for beams, &c., makes a good material. In appearance this tree is twin brother to the Kahu or Arjun of the C. P. and Upper India (*Terminalia Arjuna*) and it was not till I had been about my forests sufficiently to know that this latter tree is rare in Coorg, that I could disabuse myself of the belief that the Mattis I saw were Kahus.

The remaining trees mentioned in my list are used for building purposes and are mostly cut as poles. Coffee is transported in bags, we therefore have not here to solve the problem of a suitable wood for boxes which gives such trouble to those whose lot is cast in tea growing districts. But there is a peculiar interest in the Noga (*Cedrela Toona*). Every reader of this journal knows how valuable the wood of the Tun is considered in Upper India but here it is practically unsaleable. It grows to be a magnificent tree, often in the ghats being the largest in the forest. But the timber, as an article of commerce, is unknown. I was disappointed in the attempt made to have the wood tested as a material for furniture but I hope, before long, to discover whether the wood is as good here as in the North West Provinces. The quicker growth may possibly affect its hardness and the wood may not be of the quality it is further north, where the growth is slower, but I may be able to tell you the result of my experiments.

The detailed description of Evergreen trees must be put off till next number.

G. H. FOSTER.

Useful Maxims for Tree-planting.

In making plantations, if you wish your plants, whether they be forest trees, fruit trees or others, to prosper and develop well, *plant them on a level with the ground.*

Forest trees spring from seed which has fallen on the uncultivated ground which is often hard, covered with herbs, or other plants, and seldom so well adapted to receive the roots as the holes in which artificial sowings are made. All the conditions in a forest are generally less favourable, except one and that is that seeds rest *on* the ground.

Take for example large trees of any species. The strong protruding roots which have come half out of the earth at their birth, at their point of attachment to the trunk, do not these show what position is natural and necessary to them with reference to the surface of the soil ?

Trees buried beneath mounds of earth, offer a proof of the reverse. They either die or languish until they are able to establish a system of surface roots and by that time the old ones are dead, the reason being that roots require air just as much as water and nutritive materials.

As a rule in planting trees, a hole is made more or less deep, the root of the plant is placed in this and then the hole is filled with soft earth. The collum of the root is already below the level of the soil, and gradually the soft earth shrinking and becoming more compact, sinks down, and the collum, as well as the roots, sink with it to some 6 or 8 inches below the surface of the ground. Ere long it becomes necessary, that is in two or three years when the worked up soil has again become hard, for the roots to raise their extremities in order to live, or for new roots, not so good as the old ones, to develop above these latter.

The success of planting on ridges, recommended for wet soils, is easily explained and shows clearly the advantage of surface planting which is general. In planting, therefore, wherever possible, deep holes should be made, but these should be refilled with pulverized earth pressed down a little with the foot before the plants are placed in them. This earth will then retain moisture well and this will rise gradually as the surface soil dries and assure the success of the transplant. The roots of this latter should not be placed deeper than the surface of the soil and in covering them with a small heap of the best earth available, instead of pressing this down to the bottom of the hole as is often done, the roots of the young plant should remain undisturbed and the gradual sinking down of the pulverized earth will slowly bring down the collum of the root to the level of the soil.

This method is always applicable. One may see quite young plants of Spruce Fir, for instance, which have been deeply buried in the soil, linger for as much as 10 years before beginning to

increase in height. How is it possible that the roots of such a tree, which are essentially spreading roots, should develop at a depth of 8 inches below the surface? If the transplants are of large size, whether fruit trees or forest trees, before filling the hole place in it a proper support and do not fix the tree until you have arranged to support the collum at a fair height above the soil. Trees planted thus with the collum 6 or 8 inches above the level of the soil succeed astonishingly well. In rocky, hard or unfavourable soils, surface planting is absolutely essential, the future success of the plant is thereby assured; whereas if the roots are buried in the rock, in holes or among stones, they will die off sooner or later. The precautions to be taken in order to favour the re-growth (such as covering with grass, moss or stones) are well known and perhaps less important. Surface planting meets every case, even the most difficult.

Finally, make experiments. Take a number of similar subjects, plant them, some with the collum 8 inches deep, the rest with it 8 inches above the level of the ground, and note the development of each, the results will prove the truth of what is stated above.

C. B. in *Révue des Eaux et Forêts*
of February 10th, 1892.

II.—CORRESPONDENCE.

The Seeding of Bamboos.

Sir,

The following information regarding the flowering and seeding of bamboos in the Darjeeling District is taken from the draft Working Plans Report for the Darjeeling Forests, prepared by Mr. Manson:—

“*Maling*, Nep. (*Arundinaria racemosa*, *Munro*.) Flowered in Sikkim at the end of 1888—thirty-one years since the last recorded time. (Authority, Mr. J. S. Gamble). *Gopi*, Nep (*Cephalostachyum capitatum*, *Munro*.) Flowered at the end of 1874 and died after seeding (Authority, Mr. Stölke and Gamble’s Manual of Indian Timbers). *Nibha*, Nep. (*Bambusa patellaris*, *Kurz*.) Flowered at the end of 1861 and died after seeding (Authority, Mr. Stölke). *Nigala*, Nep. (*Thamnocalamus spathiflorus*, *Munro*) Noticed by Mr. C. G. Rogers to be flowering at “the end of 1889.” This last species called *Nigala* by the Nepalese was identified in Calcutta as *Arundinaria spathiflora Trinius var. aristata*. It came into full flower during the winter of 1890 and ripened its seed about May 1891. The seed was beginning to germinate at the end of May 1892. This bamboo is found principally above 10,000 feet elevation and occurs mixed with *Rhododendron* and *Silver Fir*.

H. H. H.

Fires caused by bamboo-friction.

Sir,

It would be interesting to know of the experiences of others regarding the firing of forests by bamboos when in friction. Last summer a fire took place in a block under special protection which I could only attribute to some natural cause. It occurred on the *windiest of windy days*,—at a locality four miles distant from the nearest village,—and in the vicinity of a check line running north and south—this line had been cleared and burnt long before of all combustible matter for a width of almost 40 feet. The wind was blowing due *east*, so had the fire occurred to the east of the line, no power on earth could have checked its progress on such a day until sundown; and instead of a few hundred acres, many square miles of forest must have been burnt. And had any one maliciously fired the block—he would not have chosen the *east* of the check line. And had any one left the remains of his pipe on the line—with such a gale it could not have spread to the west side.

The fire seems to have originated on a small hill on which were (and are) a quantity of dry bamboos. Also it took place about midday—a time in the hot season when Natives will not willingly stir out, or go far from their villages. Therefore, considering all the circumstances, I could only come to the conclusion that bamboo-friction caused this fire.

We all know that the forest villagers frequently light their fires, &c., by rubbing two pieces of dry bamboos—so in certain very exceptional cases (such as violent storms) why should this not occur naturally?

E. D.

Reproduction by Extraction of Stumps.

SIR,

In an interesting article on the exploitation of the '*Quercus Ilex*' in Provence, in the February number of the *Révue des Eaux et Forêts* the success of the rude but well known method '*saut du piquet*' is described, the result being the growth of numerous root suckers, which fill up blanks, and make the reproduction of the forest much more complete than it would be with coppice shoots only.

It is some years since in the Punjab we recognised that the regeneration of '*Jand*' (*Prosopis spicigera*) in the "*bar*" forests depends chiefly on root suckers; at all events, that any improvement in the way of filling up blanks will be accomplished in that way and not by seed; hence the practice of leaving a large number of seed trees has been abandoned, and various experiments made with the object of increasing the crop of root suckers.

It is well known that these shoots from the roots of trees of which the stumps and main roots even have been dug out on the

compartment lines, are almost impossible to kill : year after year they have to be cleared away to keep the lines open.

This experience seems to point to the probability of the success of the 'saut du piquet' method being as great with 'jand' as with the *chêne vert*.

Hitherto our efforts have been rather in the opposite direction, tending to preserve the stumps most carefully, contractors being obliged by special clauses in their agreements, to have the stumps cut in a smooth and regular manner.

Possibly, if the contractors were instructed to break up the centres of the stumps and then cover them with soil, branches, etc., the result might be a considerable increase in the number of root suckers.

At all events, no harm can be done by making the experiment.

It would be of much help if some Forester would kindly give an illustration of the peculiar axe used in Provence for splitting the oak stumps, or else give a clear description, for that in the article referred to above is difficult to understand.

C. F. E.

A Departmental Blazer.

SIR,

I wrote to you a short time ago (December) on this subject, but seeing that a blazer had been or was about to be adopted *for the Forest School students* (as I then understood), I proceeded with the business I then had in hand, *viz.*, a blazer for the Indian Forest Service (Imperial), and am now in treaty with the Army and Navy Stores (who do much in this line) about patterns, which I expect to receive shortly. In my former letter I deprecated a bicycle club badge, but suggested that if we must have one, a tree would be the proper thing. As a motto is now wanted, I suggest that nothing is so truly apt for the forester as "*Ars longa vita brevis.*" My latest pattern is a modest harmony of two quiet greens, one as ground color, the other more sparingly used to lighten it up. I have got a good many orders already, though the pattern is not finally settled, and expect all the men down here will go in for it. But before doing anything final, I will send you the patterns for discussion.* I then propose to send round a pattern to all Imperial Officers inviting them to order a blazer. As soon as about 40 are ordered, the cloth will be made. I hope all those who desire to contribute hints or opinions will do so promptly, as the matter is already arriving at a practical stage on our side, and it would not do for Bombay men to adopt a blazer that was not accepted elsewhere.

VELLEDA.

* We shall be glad to see them and send them to such of our correspondents as are interested in the subject.

HON. ED.

DEAR SIR,

I should like to make a suggestion with reference to the correspondence in the *Forester* regarding a 'Departmental Blazer.' Why not simply have a crown* above the monogram I. F. S. and no motto below? Old Coopers Hill men will remember the R. I. E. C. boating blazer, the ornamentation of which simply consisted in the monogram R. I. E. C. in old gold with a crown above of the same colors, and it was voted by all to be as neat and sensible a badge as could be wished for.

Messrs. Preston and Pigott, who make the Coopers Hill blazers, would be, I should think, very good people to supply samples to be submitted to the Committee as proposed by 'T' in his letter in the June number.

OLD COOPERSHILLIAN.

* We are rather in doubt as to the right of the Department to a 'crown' as a badge, such as is allowable to *Royal* Corps and Institutions. At any rate it would have to be an Imperial crown, we presume.

HON. ED.

The appointment of Foresters.

There seems to me to be a failure in the system of appointing "Foresters." The rules insist on their having passed the Middle Class Examination, no doubt in order to secure men of some *general* education. Unfortunately, mere general education is by no means sufficient for men who have such technical duties as have foresters—duties, too, absolutely demanding experience. Almost the only men available under this examination rule are schoolboys or bazar bred individuals with flowing robes and odorous of "hing" and "ghi."—Such creatures are, of course, impossible. Just fancy them controlling operations at a forest fire! The terror and hardships of a forest life are not for such as these. Give us straight men as hard as nails. If I quote my own Division as it was a short time ago, I shall give a good example of the "impassé" to which we often come. I had seven Ranges and four of them were held by Forest Guards—though three were lumped together into a Sub-Division under the Solitary Ranger I had, Foresters were not available from elsewhere and no single Forest-guard in the Division had passed the Middle Class Examination.

To remedy this state of things I think the best system would be to abolish the Middle Class, and substitute a *Departmental*, examination to come, as hitherto, at the step up to the Rs. 15 grade. In this departmental examination I would have a few heads to obtain fixed minima in which is a *sine quâ non*, but among the remaining subject; deficiency in some heads should be able to be overcome by proficiency in others.

†For the important ranges of the future we are to have rangers appointed from the School, and, though I think more experience should be required of them, that is not what we are now considering—it is here only a question of the minor ranges to be held by foresters. My suggestion with reference to these is that no man should be appointed straight to a Forestership, but should begin as a guard and that every literate guard should be in a position to rise to Rs. 40. This would give a continual stimulus to good work and honesty and the “be-uméd” men—to whom the only object remaining is to make money dishonestly, would tend to disappear. But, of course, this would only be possible if the compulsory subjects were very elementary—and I think they should be; for minor work what we chiefly want is sturdiness and experience.

The Middle Class Examination in these provinces was, I understand, as follows, this year :—

Bhusa Bhasker—Hindi reading apparently.
 Gutka, 3 parts ditto
 Hunter's History (in Hindi.)
 Geography (ditto)
 Euclid 2 books (ditto)
 Mensuration (ditto)
 Arithmetic (ditto)
 Chandrika Prakirt (?)

I would suggest, as a substitute, the following subjects, those marked with an asterisk being the compulsory subjects :—

- * Reading in the vernacular.
- * Writing in the vernacular.
 Dictation in the vernacular.
 Reading maps with intelligence.
 Surveying up to the standard of a Patwari.
- * Arithmetic—including Decimals and Rule of Three, but not the highest part of the subject.

General considerations as :—

Intelligence, *activity, power of control, *integrity, experience.

Thus, provided only a guard got the required minima in the compulsory subjects, his being unable to make marks in such subjects as surveying, or dictation, might be counterbalanced by high marks in such heads as experience—or Power of Control,

†.Note.—Our correspondent can also get Foresters from the School. Just now, there are about six private students of the Vernacular Class all anxious for employment.

thus enabling really deserving men to get on. And I would further prevent clever but morally inferior men from advancing, by giving them *minus* marks in the moral subjects.

The Departmental Examination might be held in each Circle when necessary—under the orders of the Conservator during the recess season.

There are some other points in connection with the Protective Establishment which I think might be altered with advantage, though, no doubt, they are not of paramount importance.

One is that of uniform. I think this should be approximate as far as possible in all the provinces under the Government of India, for somehow I think this would increase *esprit de corps*, and smartness in minor arrangements certainly tends to raise the status of the Service and to make the men feel there is "izat" in belonging to it. Thus when I see a guard slovenly dressed, I tell him that if he doesn't know how to wear the Queen's uniform, the right shall be taken away from him.

The Forest guard's uniform of these provinces seems a passably good one and serviceable, though no doubt it might be improved upon. Perhaps, for example a material of stronger texture might be found, and the men might have the option of having a woollen khaki-dyed uniform in cold weather. Then I certainly think "puttees" (of the same colour as the dark part of the puggri) should be insisted on—at least in the cold weather. The green edging always fades and look shabby and might without much harm be abolished. As to the dark green of the puggri, it would appear that no such thing as a green (save perhaps an awful pale green that is altogether impossible) that is fast-dyed is to be had and I would suggest pomegranate, which I believe could be used locally for re-dyeing (but am not sure). Boots, too, would certainly be most useful, but would have to be supplied by Government for they could not be got for less than Rs. 3-8 a pair. There would be no necessity to have square-toed boots three-sizes too large, like the North-West Provinces Police. It is most ludicrous seeing a guard pick up his shoes and rush through thorns and over stones to catch a delinquent.

Another alteration I should like to see would be the abolition of the word "Guard." The good old English terms are "Ranger," "Forester" and "Verderer:" we can dismiss the last, but I think it would be better to have Rangers, including in the term all the existing grades of Forester, and Foresters which could correspond to the present Forest Guards. In John's times and thereabouts, the men employed to guard the royal shikar forests were I believe called "King's Foresters." The word "guard" recalls Military ideas and for goodness sake let us not pretend to be Military when we are not—the more especially as we have such a rich and picturesque body of tradition on which to draw.

A. G. HOBART-HAMPDEN.

III.—OFFICIAL PAPERS & INTELLIGENCE.

Rules for the study of Forestry by officers on furlough.

In view of the importance of maintaining in the Forest Departments of India a continuous knowledge of Forest systems of Europe and, for the purpose of encouraging the study by their officers of Continental Forestry, the Government of India have, with the concurrence of Her Majesty's Secretary of State, decided that the privileges set forth in the rules appended to this Resolution may be granted, with their previous approval in each case, to selected officers of the Forest Department when on furlough.

The improvement of State Forests in India has depended, and will for some time continue to depend, in no small measure, on the adaption to them of scientific principles borrowed from France and Germany. Under existing arrangements, candidates selected for the Indian Forest Service undergo a preliminary course of practical instruction, for a few weeks, in the forests of either France or Germany; but progress in forestry is on the Continent so rapid that the knowledge which they acquire during their comparatively short tours, and at a time when their practical acquaintance with the subject is only commencing, is found to be insufficient for the needs of forest administration in India. It has therefore been determined to give facilities to officers, who have proved, by the merit of their work in India, that they are capable of assimilating and turning to account useful knowledge, to study forestry on the Continent when absent from India on furlough. Such officers if carefully selected, would, it is confidently anticipated by the Government of India, be enabled, both by their special capacity and their practical experience of what is required in India, to bring back with them and introduce into Indian Forest administration the most important improvements of the continental systems which may be applicable to this country, more specially in connection with the preparation and control of Working-Plans, in which exceptionally technical branch of forestry the greatest advance has recently been made in the Forest Departments of the Continent.

Rules under which selected officers of the Forest Department in India may be authorized to study during furlough, at the public expense, forest operations on the Continent of Europe.

I. A Forest Officer desirous of obtaining permission to study forestry on the Continent, under these rules, must submit an

application, through the Conservator under whom he is serving to the Local Government.

II. The Local Government will forward the application to the Inspector-General of Forests, with the remarks of the Conservator and its own recommendation in the case.

III. The Inspector-General of Forests will submit the application to the Government of India for orders.

IV. The Government of India will require to be satisfied that the officers applying is likely to profit by the additional experience he will gain by Continental study and that he possesses a sufficient knowledge of the language of the country which it is proposed that he should visit.

V. The application must reach the Government of India not less than four months before the date on which it is proposed to commence a Continental tour.

VI. If the application is sanctioned, the officer should place himself in communication with the Inspector-General of Forests, under whose instructions the plan of study proposed will be arranged.

VII. On arrival in England the officer will report himself at the India Office; and it will then be decided by Her Majesty's Secretary of State what localities he is to visit.

VIII. The total period to be spent on deputation will not, as a rule exceed six months. At the end of that period the officers selected will submit to the India Office a diary showing how his time has been spent, and a report which should indicate fully the nature of the operations studied, and which should also include suggestions as to the application of such operations to India. The Secretary of State will decide whether the diary and the report show that the time of the officer has been properly employed, and will determine accordingly for what period the daily allowance admissible under Rule IX may reasonably be granted.

IX. Each officer will be paid, through the India Office, the cost of a 1st class return-ticket between London and the place to which he may be initially deputed, and will also subject to the preceding rule, be granted a daily allowance of 10 shillings during his stay in the Continental forests. Travelling allowance bills in full detail must be submitted to the Revenue Secretary at the India Office.

X. The reports, notes, and drawings submitted by an officer may not, without the previous permission of the Government of India, be communicated to any professional journal or institution; and the Government of India will be at liberty to print, publish or circulate them should they think fit to do so.

Report on the physique of Junior Forest Officers.

We have received copy of a Government of India Circular on this subject dated May 20, calling for "a report on the physique and suitability, in respect to general health and constitution, for Forest duties, of each of the Forest Officers who have been appointed from England by Her Majesty's Secretary of State since 1887-88, *i.e.*, who arrived in India during the years 1888, 1889, 1890 and 1891."

The Resolution goes on to explain that—

"The object of this enquiry is that the Government of India may, if the facts elicited should seem to require it, submit further representations to Her Majesty's Secretary of State as to the necessity of employing great caution in selecting candidates for a service in which a sound physique is so essential, both in the interests of the State and those of the officers who belong to the Department."

The new Edition of the Code

It seems that there is some hitch in bringing out this, so the Government have published Part I and the Appendices first of all.

We hope that the hitch means that the Code is to be simplified and the number and size of forms reduced, one signature only being required on pay and travelling bills instead of the many now insisted on.

We also hope that the authorities will utilize the delay in giving us once more our Departmental List now missing for a year and a half?

Report of the Board of Control of the Forest School Dehra Dun.

We select from this Report the following portions which we think are most likely to interest our readers. The Board for the year 1892 consists of the Inspector-General and Director as usual, with Mr. E. P. Popert and Major Bingham, Conservators. We hope that some of our correspondents will give us their opinions on the last paragraph.

"That the Board have observed the low marks obtained in mathematics at the final examination in March of the current year. They are convinced that this result is due to the fact that the questions set were, for the most part, on the application of

'Instruction in Mathematics: text-book required.

' mathematics to practical forestry. The Board consider that questions of this character are essential, and have ascertained that the want of a suitable text-book is much felt. They recommend, therefore, either the translation into English of Koenig's *Först Mathematik*, or that the preparation of an original work of similar character should receive attention. The Board are of opinion that the grant of an honorarium of Rs 600 should be offered for this purpose.

' That the Board are of opinion that the degree of prominence accorded to Sylviculture in the final examination is insufficient. They accordingly prescribe that, in lieu of the marks allotted for this subject by the Board in 1891, the following should be substituted:—

' Forestry	{	Sylviculture 500	} 1,000.
		Working-Plans 250	
		Utilization 250	

' That no student, whether Government or private, who (a) has been unable to present himself at the final pass examination, or (b) who, having presented himself, has failed to pass that examination, shall be admitted to appear at a subsequent pass examination, unless he follows a second time the whole course of instruction at the School, or, at the discretion of the Director, the second year's course.

' The Board are struck by the constantly increasing number of European and Eurasian students admitted to the School, presumably attracted thereto under a misapprehension of the rules and conditions of the Service and of the prospect of their attaining to the higher posts. As a matter of fact, a certain percentage only of the passed students can attain to the rank of Extra-Assistant Conservator, and can only reach that rank after several years of approved service. In many instances the conditions of the administration of a forest range are such that an European is not so suitable as a native for the work required. The Board consider that the admission of Eurasians and Europeans to the School should be discouraged, and desire that the Inspector-General of Forests be requested to bring the subject to the notice of the Government of India.

' The Board having taken into consideration the question of the cost incurred by students living at the School, the Deputy-D irector gave, as an estimate of this cost, Rs. 75 to Rs. 85 per mensem, independently of travelling expenses. The Board consider this cost too high, and cannot recommend Government to subsidize the students above the pay to which they are entitled when on service in their Circles. The principal question is the cost of joining and continuing in the mounted volunteer corps.

‘The Board fully recognise the value which the students derive from learning riding and discipline. The latter could be equally well obtained by a foot-corps. The Instructor, in charge of the forest division of volunteers, showed that the purchase and hiring of horses devolve entirely on the officers of the corps, and that the only outlay which a student has to incur is Rs. 15 per mensem for the up-keep of a horse. But even under these circumstances the Board consider that, as the students are in effect obliged to join the mounted rifles, no part of the expenditure incurred should fall on them or on their parents. The Military Department should be addressed by the Inspector-General of Forests with a view to obtain for each European student the use and feed and keep of a mount during his stay at the School. In the second place, the Board, having inquired into the question of the cost of athletic clubs, find that there is but one such club at the School of which the subscription is voluntary and amounts to Rs. 4 per annum only, and are of opinion that the students should be encouraged to join this club.

‘That, with reference to the following Note, which was placed before the Board for consideration, an immediate Resolution thereon would be premature; but that the Inspector-General of Forests be requested to cause the proposals therein contained to be circulated to Local Governments in order to obtain the opinion of Educational and Forest officers; and that the subject should be brought forward for final discussion at the meeting of the Board in 1893 :—

Note on the subject of securing a better quality of Native Candidates for the Forest Department.

‘The subject placed before the Board, for consideration, is that of securing a better quality of native candidates for the Forest Department.

‘There is no doubt that hitherto the standard reached by the average of native candidates who enter as students has been very much below what it should have been when the facilities given, at public expense, for education in this country are considered. This, it may be admitted, has been partly due to the insufficiency of the prospects offered, compared with those offered by other official services, but not altogether so. Other causes, which will be dealt with further on, have operated. Prospects, however, have now improved, and it is perhaps all the more important to take care that other causes do not interfere with the attractions which they offer and prevent the Forest Department from securing the best candidates available.

‘The “other causes” which lead to a low standard of qualifications in forest candidates are :—

‘(a) Insufficient knowledge in our educational establishments of the conditions and advantages of the Forest Service.

- (b) Absence of competition before entry. [If *A, B, C, D, &c.*, are candidates for nomination, *A* being better than *B*, *B* better than *C*, and so on, *D* has just as good a chance of being nominated as *A*.]
- (c) Absence of strict conditions in the matter of nomination. [A Conservator or a Secretariat official may send up any one he pleases—the son of his Head Clerk, &c.—who is likely to pass the entrance examination.]
- (d) Absence of competition after entry. [This does not affect, it is true, the quality of the candidate, but it affects his value when turned out of the School as a passed student.]

The following principles or canons are suggested as a desirable basis for any scheme framed with the subject of improving the quality of forest students:—

- (1). *A forest education is a close and special education which is not suitable for any other profession.*

This principle is acknowledged at Coopers Hill College. Consequently the students for the Forest Department are selected by competition before entry and not, as in the case of Engineers for the Public Works Department, at the end of the course. The second canon to be laid down might, therefore, be formulated as follows:—

- (2). *There should be competition for Forest Studentships before entry to the School.*

But, as each province has to nominate its own forest officials, it is necessary that—

- (3). *There should be separate competition in each province.*

In view of the desirability that the Forest School should not be burdened with an excessive number of students, and also of the fact embodied in canon (1)—

- (4). *The number of candidates selected from each province should be limited to the number for whom it is likely that appointments will be available.*

In order to attract the best possible candidates, a portion of the allowances which Local Governments are empowered to grant should be offered as scholarships. It should, therefore, be laid down that—

- (5). *The students who succeed best at the provincial examination should receive scholarships.*

The scholarships might be say, Rs. 30 a month. But in order that students unfit for forest work may not be allowed to gain scholarships, a preliminary personal examination of them should be made beforehand by a Board, of which Conservators and selected Deputy-Conservators should be members, who would reject, *in limine*, unfit candidates. Some rule should, therefore be laid down to the effect that—

(6). *No candidates should be allowed to compete for forest scholarships until they have been passed by a Forest Board as fit for forest service.*

In order to induce competition at the School, the remainder of the allowances now given by Local Governments may be offered in the form of six-monthly prizes to those students who succeed best. Students might be divided into, say, four classes—

Class 1	would get, say	Rs. 20	a month
" 2	"	15	"
" 3	"	10	"

for the next six months. If all the students did sufficiently well, they would all go into Class 1. Special money-prizes might also be given to those who did best. Class 4 would get nothing. But the principle laid down should be that—

(7). *In order to stimulate exertion at school, a portion of the provincial allowances should be utilized in the form of six-monthly prizes or school scholarships.*

Whether it is worth while to go further than this, and make any conditions as to future promotion in the Forest Department depending on success at the School, is perhaps doubtful. Success at school would presumably always be taken into account in promoting from rangerships.

The suggestion may be added that any rules laid down for the examination for provincial scholarships should be approved by the central Forest Board. It would be a matter on which all Conservators should perhaps be consulted.

It seems desirable that at provincial examinations marks should be given for natural sciences, which are now in India beginning to receive some attention at the schools. The subject may be made an optional one, but should not be overlooked.

There seems to be no reason why private students should be encouraged to come to School. They need not be excluded. But when the new re-organization scheme has once got into working order, it is difficult to see what chance there will be for private students to obtain appointments.

A suggestion may be offered that provincial Conservators should be invited to take personal trouble to induce the masters of schools and colleges to pick out their most suitable students as candidates for the forest scholarships. Marks might possibly be allowed for special certificates from schools; but, however this may be, there is no doubt that personal selection of fit candidates, in communication with the best masters and teachers in a province, will be found very useful. This plan was acted upon with considerable success in choosing candidates for the Land Record Department in the North-Western Provinces. It is considered that the time will soon come when the progress of education will bring forward many more candidates for forest service than now apply for it, and it would seem to be as well to lay down rules and principles regulating competition before the rush comes.

IV.—REVIEWS.

Annual Forest Administration Reports of the N.-W. Provinces and Oudh, and Coorg for 1890-91.

We have now gradually but briefly reviewed most of the Reports for 1890-91. One by one, we have referred to the chief works done in Bengal, the Punjab, Assam, Baluchistan, the Central Provinces, Madras and Berar. The Reports from Burma and Bombay have not yet reached us. In the Report on the *North-Western Provinces and Oudh* there is not much which calls for special remark. We fully approve of the remarks made both by the Local Government and the Government of India on the necessity for strict adherence to Working Plan Provisions. We would even go further than the Government of India and allow no changes, except of the utmost urgency, until a general revision takes place; otherwise we should have officers holding different opinions altering each others works so constantly that it would be next to impossible to maintain proper record, certainly not such a difficult record as that prescribed by Forms 2 and 3 of the Code. At the same time, though we think that the main provisions of Working Plans should be very strictly kept to, we consider that greater latitude should be given to Conservators especially in such questions as works of improvement, for it seems rather absurd that they should have to obtain special Government sanction when they have funds to spare and can do an extra amount of creeper-cutting or planting to the benefit of the forests.

The remarks on 'Natural Reproduction' in the Central and School Circles evidently refer to different years, for while the Central Circle Report comments on the absence of Sal seed (probably in 1891, but if so, it must have been after the close of the year), that of the School Circle says it seeded well, in 1890. As a matter of fact, 1890 was a good year for Sal seed, and 1891 a very bad one. Both Reports speak strongly on the damage done by frost in the Sal forests in the winter of 1890-91.

The discussion of the question of half-measures in the Chir Forests so as, on the one hand, to get some reproduction and on the other to let the hill people go on with their favourite amuse-

ment of firing the fine-needles, goes to show that such half measures are not very likely to succeed. In our opinion there is only one possible measure and that is protection from fire; and if it is found desirable to keep the grass from being spoilt for grazing, money must simply be spent in clearing away the pine needles artificially. Whether the villagers will agree to this, is perhaps doubtful, and if it is impossible to ensure fire protection, it seems to us that there is nothing for it but to consider the areas simply as grazing lands and abandon any hope of maintaining a permanent forest. The Government of India have quite rightly remarked that "no improvement can take place in the condition of forests so long as their firing is permitted;" that it has for so many years been permitted in any Reserved forest without endeavours to teach the people better, is matter for some surprise.

The gross revenue of the year was Rs. 16,37,879 and the net revenue Rs. 7,18,982 so that the surplus was 44 per cent of gross receipts which is clearly satisfactory.

In the Coorg Report there is not much to be noticed except the unfortunately ill-success of the works of fire protection. We think it may be of interest to publish the following extract. "But in spite of the unfavourable season, there is good reason to suppose that the efforts of the staff would have been successful in protecting a much larger area than that reported, had we only had accidents and the results of ordinary carelessness to contend against. This however was not the case; and it may be stated with much confidence that the larger number and most destructive fires were designed either for purposes of *shikar*, or by graziers, with the view of stimulating a new grass crop, or of burning down the standing residue of the old one; while in some cases it is feared that they were caused by persons bearing a grudge against the department."

'During the month of March, in which most of the damage was done, fires were continually being lighted inside the forests. They always occurred inside, and under circumstances which increased our difficulty in extinguishing them. For example—several fires occurred on bazaar days, when it was impossible to collect assistance and when the forest coolies were absent on *private affairs*. They were also often lighted late in the evening, so that several hours probably elapsed before they were covered; and they were lighted in two or three places at once, so that our available parties were split up and often inadequate, in consequence, for the work in hand. These remarks are especially applicable to the Arkeri reserve, where 23 separate fires occurred in March, by which 12,801 acres were burnt, or 70 per cent of the entire forest. No sooner were fires extinguished in this area, than others were lighted, until the staff became completely exhausted and demoralised by the continual day and night work carried on under most trying and disheartening circumstances. Two Foresters were severely burnt in the performance

of their duties. In one case, in the Anekadu reserve, a fire was lighted in the early morning about 3 miles from the forest headquarters, and when the staff was absent and engaged on putting out this fire, a second one was lighted inside the large teak plantation at Anekadu, which was burnt from end to end. The Commissioner was good enough to inspect this latter area, accompanied by the Deputy Conservator, and the local Soubadar was ordered to hold an inquiry into the origin of the fires, and to offer a reward of Rs. 50 for any information tending to convict the offenders, but no information was obtained. In the Dubari forest—and this most unfortunately was the only case in which an offender was caught—a man was arrested by a guard when actually applying a lighted stick to the grass, and on conviction imprisoned for three months.

These facts, coupled with the circumstances relating to the planned fires of Hutgut and Nalkeri, recorded in last year's report, leave no doubt in my mind that by far the larger number of our fires are caused, not by accident or by carelessness, but on purpose; and that unless the Forest Department receives extraneous assistance either from the Revenue Department or through or some repressive action of government, such for instance, as suspending the exercise of rights in those areas where fires are most frequent, the work of protection will be more a matter of fortune, dependent on a wet or dry season, than the result of protective arrangements, however good these latter may be. It must however, be confessed with regret that the forest officials have dismally failed especially in South Coorg, to lessen the offence of forest burning by arresting the offenders; but no offence probably is so easy to commit without being discovered, and the conditions of the establishment in Coorg are adverse to an energetic prosecution of the offenders.

It is the general opinion of the forest officials, and, I may also add, of the planter community, that one of the chief causes of these forest fires is the large number of guns owned not only by Coorgs and *jama* ryots, according to the Arms Act, but by Kurubars and other jungle tribes, most of whom appear to possess one of some sort, but without license or authority for such possession. Our forests are still visited by these unlicensed sportsmen, who in the season, which unfortunately is also the dry hot season, are reported to burn the grass for tracking purposes and generally to enable them to move about freely. Were the Arms Act to be enforced in this province, and only a limited number of persons, besides those specially mentioned in the Act, allowed to use guns, I am persuaded that there would soon be some diminution in these fires."

The gross revenue of the Coorg Forests in 1890-91 was Rs. 135,561 and the surplus Rs. 69,743 or 62 per cent of gross receipts which is satisfactory.

Number of Species in the Java Forest Flora.*

We have received from M. Koorders his pamphlet which shews that there are 975 species of plants in Java affording forest trees, taller than 5 metres and with stem diameters of more than 10 centimetres. These 975 species belong to 391 genera and 76 families. As might be expected, the chief families are Leguminosæ, Urticacæ and Euphorbiacæ, but there are also many genera in Sapindacæ, Rubiacæ and Anonacæ.

*Bijdragen tot de kennis der Boomflora van Java, door S. H. Koorders, Houtvester.

Manilla Hemp.

We have before us, one in the *Révue Agricole* "of Mauritius, the other in the Journal of the Calcutta Agri-Horticultural Society," two short accounts of the cultivation of *Musa textilis*, the plant that yields the well-known manilla hemp of the Philippine Islands. One is by the English Consul at Manilla, and the other published by the Government of India, and appearing in the Journal of the Agri-Horticultural Society of India, is a report by the Extra-Assistant Superintendent of Port Blair.

It appears that the plant requires a rich soil thoroughly weeded, and a heavy rainfall; it grows better on slopes than on level ground and soil of a volcanic origin suits it best. The young plants are put out from 8 to 10 feet apart and about a foot deep in the ground.

In about three years the plant will be in full bearing, and it reproduces itself by suckers for 15 or 20 years, after which time a new plantation should be made on fresh soil.

The two reports do not agree as to whether the stems should be cut before fruiting takes place; one says they should on no account be cut down before they fruit; the other says that if the plants are allowed to bear fruit their fibre yielding qualities are lost.

The value of the fibre depends chiefly on the careful manner in which it has been dried, the sun and wind being the chief elements to consider, and rain being avoided, as the colour would be spoiled.

It is calculated that one acre of plantation will yield from Rs. 100 to Rs. 110 per annum, from which must be deducted the cost of cultivation, manufacture and packing. The cultivation of this plant which is chiefly conducted by Spaniards, is lucrative, but the conditions of living in the country are hard and a stranger would experience many obstacles and difficulties at the outset. We gather that it is intended to attempt growing the plant in the Andaman Islands.

A. S.

V.-SHIKAR.

A trip to Bara Bangahal

15th May.—Dharmasala to Palampur, 22 miles along a stony road skirting the base of the Dhaulá Dhár Range which forms the boundary between the Chamba State and the Kangra District and which is covered with snow during 6 to 8 months of the year. The first Dâk bungalow *en route* is Dâdh, a tumble-down old building overlooking a deep ravine which is crossed by a rickety bridge. About two miles beyond this, the road passes through the Gopalpúr Tea Estate, one of the most picturesque gardens in the Valley, situated on the undulating lands below the Pattyar ridge, which is thickly covered with *Pinus longifolia* with a quaint old Fort on the top. At Gopalpur, the weary traveller, be he friend or stranger, will ever receive a warm welcome from its hospitable Manager. Palampur, the head quarters of the Tehsil, is an exceedingly pretty little Station situated in the middle of a *Pinus longifolia* forest which is cut up by the many slate covered buildings dotted about over it. An exceptionally pretty little Church, and well kept churchyard, a dâk bungalow, and Sessions house, the Kangra Valley Planters' Club, Tehsil, Post Office, and a School, a Masonic Lodge, Hospital and a Planters' bungalow, built on the pattern of an English country house, form this little Station.

16th May.—Palampur to Lanode, 10 miles, along a very rough riding path through Oak, Rhododendron and Pine forests. For about a third of the way the path skirts several Tea plantations, all neatly kept, and well cared for. The view of the undulating valley below is lovely, the Tea Gardens neatly laid out, with their avenues of fruit and other trees, and the picturesque houses of the ever cheery and hospitable planters dotted about this green ocean of tea bushes, all help to form a truly pleasing sight. Arrived at Lanode, I received a warm invitation from the Manager of the Lanode Tea Estate which I gladly accepted, for with such cheerful company, and such genuine hospitality, the stay at Lanode was a pleasant incident not to be forgotten.

17th May.—Lanode to Dūdring flats about 12 miles along a narrow mountainous path with many nasty places to cross. Left the ponies and heavy luggage at Lanode. Left Lanode about 5 A. M. and reached the Manbai Gôte about 9 A. M., breakfasted here, and then started to finish the rest of the journey which was a steep pull up the whole way to Dūdring, got in by

4 o'clock P. M. after seeing some Pine forests *en route*. The lovely cool air and wild rocky scenery would cheer the hearts of most men, but when added to this is the knowledge that the wandering shikari is now in the land of bears, kurt and chamois, he truly feels a happy man. The grassy slopes all round are overrun with flocks of sheep and goats on their way up to the Alpine grazing grounds where they spend the whole summer, so the deer tribe have moved higher up into the rocks and crags. Saw several lovely Moonals and Argus pheasants, which appear to know it is the close season and let one get quite within shooting distance of them.

18th May.—Started at 4 a. m. to cross the Lanode Pass about 13,500 feet, the approach to which is decidedly dangerous, and consists of a narrow path over very rocky and precipitous ground, occasionally the path dwindling down to mere crevices along shelving rocks. It was a cold windy morning with a nasty drizzle, and under the advice of the the hill men, the crossing of the pass was delayed till the afternoon. Reached the Jalsu Flats on the other side of the Lanode Pass about 4 p. m. The country all round was under snow, and looked very beautiful. After pitching tents, we went in search of bears, but owing to a heavy hail storm, had to return to camp, having seen only a musk deer. The gently sloping hillsides with their snow-covered crowns, below the snow line the emerald green carpet of short luxuriant grass, covered thickly with the most beautiful wild flowers, the small dwarf rhododendron with its lovely flowers in full blossom and the copper-colored oak dotted about in small groves, all help to form a perfect paradise for any one fond of jungle life.

19th May.—Halted at Jalsu, rain all day. Saw fresh tracks of bears.

20th May.—Started at 5 a. m. for Yarra. Directly on arrival at Yarra, saw two splendid brown bears high up the hill to the west of the wood, one of them was a real fine beast, but they were on the move and got into the thick forest cover before I could get up to them. Late in the evening saw another bear across the ravine some distance away, so had to leave him to himself.

21st May—Halted at Yarra to-day to dry tents, &c. and send across the Pass for more provisions for the coolies. Up at dawn and up over the hills. Saw my friends the bears of the previous day. After a fearful pull up to the spot where they had been first seen, found to my disgust that they had vanished apparently into mid air ! for they certainly had not crossed the ridge which I had carefully watched. Directed the Shikaries to search a grove of Blue Pines in the *nala* below ; they reported nothing in the grove, so I climbed up to the top of the ridge to hunt for the bears in the snow, while doing this the Shikaries below shouted that the bears had broken from the Pine grove and were coming up the hill towards me. After a terrible run along the slippery hill-side, resulting in many nasty tumbles, I got within 60 or 80 yards of

one of the bears and had a quick running shot at him but missed him clean, and he was soon over the ridge and into dense cover below. Utterly disgusted with myself I scampered down the hill again, and tried to comfort myself with breakfast, which consisted of cold "dál bhat" and devil grill. After breakfast, visited the remains of what had once been a lovely Deodar Forest, but had been recklessly cut down years ago by the traders who obtained their timber from the Chamba Forests, before the Forest Department leased them. While seeing the forest, we were caught in a heavy shower of rain and got soaking wet, so determined to hurry back to camp, saw a black bear far down the hill, but we were too wet and miserable to go after him.

22nd May.—Still at Yarra; no supplies have arrived. Saw another bear high up the ridge: again a long tramp and no success. Received a post and did office work all day.

(To be continued.)

F. O. L.

VI.—EXTRACTS, NOTES AND QUERIES.

Report on the Timber Trade of Bosnia and the Herzegovian.

The superficial area of Bosnia and the Herzegovina is 51,155 square kilometres. (12,641,133 acres) of which more than half, that is to say, 26,793 square kilometres. (6,620,954 acres), is reckoned as forest. A great part, however, of this so-called forest is mere brushwood, while other parts, owing to centuries of neglect and reckless cutting under the Turkish Government, have been so devastated as to be almost valueless at present as regards their timber.

In the beginning of this century the Bosnian bank of the Save was well wooded with oak, ash, elm, and lime trees, but the facility of carriage by water tempted foreign speculators, and it is only now on looking to the left or Austrian bank of the river that one realises what these forests must once have been.

In the more mountainous parts of Bosnia and Herzegovina, far removed from the waterways, there are still extensive forests of very fine timber, in some parts even untouched yet by the axe. In the north, oak, fir, and beech predominate, in the south and west beech and various coniferæ.

It was only about the year 1830 that the timber trade in Bosnia commenced, and it was confined to the production of oak staves as requiring neither costly establishments nor carriage roads. These Bosnian staves acquired very soon a certain reputation on the foreign markets and were known in France as "Mer-rains de Bosnie" or "Bois unis," this latter term being merely a corruption of the word "Bosnie." In England all staves coming from Austrian ports were known as Bosnian staves.

When the large trees of the plain were all cut down, recourse was had to the smaller ones of the mountains, especially in the vicinity of the watercourses such as the Bosna, Una, Ukrina, and Krivaja, all of which either directly or indirectly flow into the Save. Once in the latter river the staves were loaded on boats and taken to Sissek and up the Kulpa to Karlstadt, whence they were sent by cart to the shores of the Adriatic.

The oak found in the hilly parts of Bosnia is the *Quercus robur*; only as rare exceptions in certain marshy places are found specimens of *Quercus pedunculata*, which is of quicker and larger growth than *Quercus robur*. The *Quercus robur* of Bosnia is of particularly slow growth. A tree 250 years old does not measure more than 45 centimetres ($17\frac{3}{4}$ inches) in diameter, and trees rarely attain a diameter of 65 centimetres ($25\frac{1}{2}$ inches). Those that do, already show signs of decay. The wood is softer and less durable than the oakwood of Slavonia, but on the other hand it is more elastic and easier to work. In Slavonia it is not uncommon to find trees up to 130 centimetres (51 inches, but on the right bank of the Save none such are now, at least, to be found. The Bosnian staves, consequently, run somewhat smaller than the Slavonian staves. The latter average about 4.90 inches in breadth and the former only 4.70 inches.

A forest law, dated the 11th Shewal, 1286 (January 1, 1870), existed in Bosnia under the Turkish Government, but it was never put in force, nor were there any forest employés. When the Austrians occupied the country in 1878 measures were immediately taken for the preservation of the forests from further devastation, and a forest law was drawn up based on the Turkish one above alluded to.

The present annual cost of the Forest Department is about 200,000 fl. (16,666*l.*), but there are still far too few forest guards—not more than 300—to maintain an efficient control over the vast forests of these provinces.

By the new Austrian law, all the forests in Bosnia and the Herzegovina were proclaimed to be State property, unless the ownership of private persons or of the Vakuf could be clearly authenticated. A special commission was appointed to carry out this work, which is yet far from being completed. The forests are classed under the four following heads:—State property; unrestricted rights; and private property charged with certain Vakuf (Mussulman Church property; private property with communal rights

The peasants are allowed, as before the Austrian occupation of the country, to cut wood and to make charcoal for their own use in the State forests in the vicinity of their abodes without payment, and have also the right of pasturage therein for their cattle. On all wood cut and charcoal made for sale they have to pay a tax.

For some years after the Austrian occupation the timber to be cut was sold by public auction, previous notice of the intended sales being given in the newspapers, but the system has been abandoned of late in favour of private sales.

Sales up to the value of 50 florins (4£. 3s. 4d.) can be concluded by the district authorities (Bezirksämter), and up to 600 florins (50£.) by the Departmental authorities (Kreisämter), but above that amount, only by the Central Administration at Serajevo.

The largest sale was made in the year 1886 to the house of Morpurgo and Parente, of Trieste. This house has lately failed, but the agreement with the Government is being carried out by the house of Rothschild. According to the terms of this agreement, which was to run for 10 years, Morpurgo and Parente were to cut annually not less than 25,000 and not more than 75,000 oak trees, at a maximum price for those over 50 centimetres (19·7 inches) in diameter, and a minimum price for those between 45 centimetres (17·7 inches) and 49 centimetres (19·3 inches). Payment is made annually, half in October before the cutting begins and the other half in March before exportation.

The forest receipts for the current year were put down in the budget for Bosnia and Herzegovina laid before the Austro-Hungarian Delegations at 488,200 florins (40,266£.) and for the coming year at 488,200 florins (40,683£.) but the amount actually received must be far in excess of these figures. Morpurgo and Parente alone pay annually about 750,000 florins (62,500£.), and Schesinger, of Agram, 250,000 florins (20,833£.), and the total annual receipts from forests certainly exceed 100,000£.

The cost of the staves to the cutters, of course, depends very much on the position of the forest where they are cut, and the distance they have to be carried either to the railway or to a navigable river. For instance, a thousand staves cut near the Save would probably not cost more than 50 francs (2£.) delivered at the frontier, whereas the same number from the interior of Bosnia would cost as much as 250 fr. (10£.) It is reckoned that in Bosnia three-quarters of the price of a stave goes in freight, and in Slavonia less than half. To reduce this cost, Morpurgo and Parente have constructed more than 200 kilometres of narrow gauge railway, at a cost of over 60,000£., to bring down their staves to different points on the Brod-Serajevo line. This firm has been spending annually in Bosnia in this business about 3,000,000 florins (250,000£.), of which 750,000 florins (62,500£.) are paid to the Government for the trees. It employs 3,000 workmen, almost entirely natives of Carniola and the Croatian frontier, whose

speciality is the cutting of staves. They work in gangs of eight or ten, and are paid so much per thousand for staves 36 inches long, 4 inches to 6 inches broad, and 1 inch thick. A good workman in Slavonia cuts about 10,000 staves in a season, and is paid 20 florius (33s. 4d.) to 22 florius (36s. 8d.) per thousand. In Bosnia, owing to the mountainous nature of the country, the severity of the weather, and the rugged growth of the trees, he cannot cut more than 6,000 to 7,000, and is paid 36 florius (60s.) to 38 florius (63s. 4d.) per thousand. Cutting only takes place during the winter months, and ceases at the end of April.

The staves are mostly sold either at the nearest station of the Bosna Bahn (Brod-Serajevo line) or at Sissek, which is the principal market for this article, whence they are sent by rail to Fiume or Trieste for shipment.

The rate of carriage by rail in Bosnia for staves is 25 kr. ($4\frac{1}{2}d.$) per kilometre for a truck load of 10 tons. Between Brod and Fiume the rate is only 13 kr. ($2\frac{3}{5}d.$) for the same quantity and distance. The cost of carriage on a thousand staves from Doboj on the Bosna Bahn to Fiume is about 3£.

The sales are always effected for ready money without discount, and the French dealers, who are the best customers, even make considerable advances.

Besides Morpurgo and Parente, who are, however, by far the largest cutters, the following firms have also agreements with the Government:—

Carl Schlesinger, of Agram ;
L. Blazic, of Sissek ;
Milic and Sons, of Banjaluka ;
Brabetz, of Gradiska ;
Volks-Actien Bank, of Serajevo.

There has been an enormous increase during the last five years in the number of staves exported from Bosnia, as will be seen from the following table:—

Year.	No. of Staves Exported.		
1886	2,500,000
1887	6,000,000
1888	8,000,000
1889	14,000,000
1890	26,000,000

I believe these figures to be even below the mark, and have heard last year's exportation estimated at as much as 30,000,000. The average price per thousand, delivered at the frontier, during this period, may be put down at not less than 225 fr. (9£.). The value of this trade has therefore risen, at the lowest estimate, from 22,500£. in 1886 to the very considerable sum of 334,000£. in 1890.

About 90 per cent. of the staves produced are what are known in the trade as French staves, and the remaining 10 per cent. as

German staves, these latter being larger, thicker, and more coarsely cut for the manufacture of large barrels.

France takes nearly three-quarters of the number exported. The next best customer is Italy, and then Algeria, England, Portugal, and Spain, in the order here given.

The staves for France are principally shipped from Fiume and those for Italy from Trieste. Fiume would be a more natural port for Italy and the cheapest to reach with the staves, but as they are chiefly loaded on small Italian sailing craft these latter prefer Trieste, for which port it is easier to find a cargo from Italy.

Fiume, however, is rapidly supplanting Trieste as a port of shipment for staves. In the last 10 years the annual exportation from Fiume has risen from 2,500,000 staves to 48,000,000 staves, while the exportation from Trieste has fallen from 41,000,000 to 13,000,000.

Trieste and Fiume being no longer free-ports, and the interior of Bosnia having been brought into direct railway communication with the Adriatic by the completion of the Serajevo-Metkovic line, unforeseen changes in this trade may not unlikely occur much to the detriment of the above-mentioned ports.

The trade in staves is said to be passing through a very critical period. The production is ever increasing, but not the demand, and the capital engaged bears at present but a low interest. There is also the fear that the oak forests of Thessaly and Asia Minor, which are as yet untouched, may prove dangerous rivals to those of Bosnia and Slavonia.—(*Foreign Office publication.*)

A Burmese Axe-head wood.

Mr. J. W. Oliver sends us specimens of a tree called 'Tamalan' in Upper Burma. We identify it as a new species of *Dalbergia* near *stipulacea* which is rather strange as that species is a climber usually. Mr. Oliver says that 'Tamalan' wood is largely used for axe-heads, the steel cutting edge being let into a piece of it just as the flint axes of the stone age used to be made. The wood is said to be very tough and indeed it must be to stand work as part of an axe-head. It is a hard radish wood more like that of some South American *Dalbergias* than that of our Indian Blackwood Sissue.

How nutmegs are grown.

A large stock of the very finest nutmegs for seed has been imported by Jamaica from Grenada, and has been sown in the Hope Gardens and, when ready for distribution, will be sold at the very low rate of three halfpence each in large or small quantities. It is hoped that these arrangements will tend to develop the planting of nutmegs on a large scale in suitable districts in Jamaica. Already one order has been fixed for ten thousand plants and another for five thousand.

The germination of the seed in large quantities and the care of the seedlings requires the strictest attention to prevent extensive loss. From the seed-bed the seedlings are transferred to bamboo pots, and, when they have quite recovered from the transplanting and have formed good roots they are ready for the nutmeg plantation.

Nutmeg trees require a deep, rich, loamy soil, moist but not swampy, with a humid atmosphere. They thrive best in steamy river valleys from the sea level up to three hundred or four hundred feet, but they will grow in favourable situations up to an elevation of two thousand feet. The trees should be placed at distances of twenty-five to thirty feet apart, and if the situation is not naturally shady and sheltered, trees should be planted for the purpose of breaking the wind as well as for shade. The trees are a long time coming to maturity, not producing a crop as a rule till they are nine years old, and only when they first flower at six or seven years of age; it is possible to determine whether they are male or female.

A very small proportion of male trees is left for fertilization by insects, the rest are cut down and fresh plants are substituted. The fertile trees continue to produce fruit for seventy or eighty years. On an average, each three will yield ten pounds of nutmeg and about one pound of mace every year.

The nutmegs are picked up from under the trees every day except Sunday. On being brought into the boucan, the mace is peeled off and pressed flat between heavy blocks of wood, where it is left for two or three days, then put into a case and left till it reaches the proper colour. The nutmegs are put into receptacles (with fine mesh bottoms, so that the air can pass through) inside the boucan, and left there for three weeks or a month.

They are then shown the sun for a couple of hours a day, for two or three days. After this they are cracked. Great care is necessary here, for if the outside shell is struck too hard it makes a black spot in the nutmeg, which affects the value considerably. When cracked, the nuts are sorted according to size, put into ordinary flour barrels and shipped.—(*Indian Agriculturist*).

The new head of the Woods and Forests Department at the Cape.

The appointment of Mr. D. E. Hutchins as Consulting Forest Officer at head-quarters, is one of the most important made of late, as it virtually means his elevation to the chief post in that branch of the Service, only in lieu of being called Superintendent of Woods and Forests, as was the Comte de Vasselot, Mr. Hutchins will be known as the 'Consulting Forest Officer' of the Agricultural Department. Mr. Hutchins has been connected with the Woods and Forests service since 1869, when he passed 5th out of 85 candidates for the Indian Forest Service, went to the Nancy School of Forestry for three years, and then to Scotland for a special course of forestry instruction. He served in India from 1872 to 1883, when he had reached the high grade of Deputy Conservator of Forests. In that year he was transferred temporarily to this Colony and was appointed Conservator of Forests, which post he has filled with distinction since. At the International Forestry Exhibition in 1884 Mr. Hutchins was awarded a diploma for a collection of Cape woods. In 1889, Mr. Hutchins published a highly interesting brochure on "Our Climate, Cyclical Variation, and Sun Spots" in this paper, which was reprinted in book form and circulated throughout the world. During 1890, Mr. Hutchins visited Europe and visited the French and German forest schools and forests and was specially impressed with the great improvements introduced into the German forestry system. Mr. Hutchins surveyed the face of Table Mountain on his return from Europe in August last and reported favourably on its reforestation. We tender our sincere congratulations to Mr. Hutchins on his promotion.—(*Wynberg Times.*)

VII.—TIMBER AND PRODUCE TRADE.

Market rates for products.

Tropical Agriculturist. 1st July, 1892.

Cutch	per cwt.	24s.	to	34s.
Croton seeds	"	15s.	to	20s.
Gum Kino	"	70s.	to	72s. 6d.
India Rubber, Assam	per lb.	1s. 6d.	to	2s. 2d.
" Rangoon	"	1s. 8d.	to	1s. 10d.
Myrabolams, Bombay	per cwt.	9s. 3d.	to	10s. 3d.
" Jubbulpore	"	8s. 6d.	to	9s. 6d.
" Godavari	"	9s. 3d.	to	10s. 3d.
Nux Vomica, good	"	9s.	to	10s. 6d.
Orchella	"	20s.	to	25s.
Red wood	per ton	£3.	to	£3-10s.
Sandal wood, logs	"	£35	to	£60
" chips	"	£9	to	£30
Sapan wood	"	£4	to	£7

Statement of average selling rates of timber and bamboos in Meerut, Cawnpore, Bulandshahr, Pilibhit, Bareilly, and Moradabad for the quarter ending 30th June, 1892.

Description.	Timber Scantlings per score.		Bamboos per 100 score.		REMARKS.
	From	To	From	To	
MEERUT.					
Sal 10' Tors (Poles) ...	R. A. P.	R. A. P.	R. A. P.		
Sal Karris, 12' x 5" x 4" ...	8 0 0	18 0 0	
Sal bed posts, 7' x 2½" x 2½" ...	25 0 0	40 0 0	
Bamboos of 9' to 10', per 100 score ...	8 0 0	10 0 0	
	28 0 0	80 0 0	
CAWNPORE.					
Sal 10' Tors (Poles) ...	5 0 0	6 0 0	
Sal, Sain &c. Karris, 12' x 5" x 4" ...	9 0 0	10 0 0	
Sal bed posts, 7' x 2½" x 2½" ...	2 8 0	3 0 0	
Bamboos of 9' to 10' per 100 score	20 0 0	30 0 0	
BULANDSHAHR.					
Sal 10' Tors (Poles)	
Sal, Sain &c., Karris, 12' x 5" x 4"	
Sal bed posts, 7' x 2½" x 2½"	
Bamboos of 9' to 10', per 100 score	50 0 0	50 0 0	
PILIBHIT.					
Sal 10' Tors (Poles) ...	40 0 0	70 0 0	
Sal Karris 12' x 5" x 4" ...	30 0 0	40 0 0	
Sal bed posts 7' x 2½" x 2½" ...	5 0 0	6 4 0	
Bamboos of 9' to 10', per 100 score	60 0 0	100 0 0	
BAREILLY.					
Sal 10' Tors (Poles) ...	5 0 0	10 0 0	
Sal Karris, 12' x 5" x 4" ...	25 0 0	35 0 0	
Sal bed posts 7' x 2½" x 2½" ...	50 0 0	60 0 0	
Bamboos of 9' to 10', per 100 score ...	10 0 0	15 0 0	
	50 0 0	137 8 0	
MORADABA D.					
Sal 10' Tors (Poles) ...	20 0 0	22 0 0	
Sal, Sain, &c., Karris, 12' x 5" x 4" ...	30 0 0	50 0 0	
Sal bed posts, 7' x 2½" x 2½" ...	10 0 0	12 8 0	
Bamboos of 9' to 10', per 100 score	50 0 0	100 0 0	

VOL. XVIII]

[No. 9.

THE
INDIAN FORESTER ;
A MONTHLY MAGAZINE
OF
FORESTRY,
AGRICULTURE, SHIKAR & TRAVEL.

EDITED BY

J. S. GAMBLE, M.A., F. L. S.,

CONSERVATOR OF FORESTS, AND DIRECTOR OF THE
FOREST SCHOOL, DEHRA DUN.

SEPTEMBER, 1892.

MUSSOORI,

PRINTED BY THE MAFASILITE PRINTING WORKS
COMPANY, "LIM. ED."

1892.

Contents.

No. 9—SEPTEMBER, 1892.

Page.

I.—ORIGINAL ARTICLES AND TRANSLATIONS.—

<i>Coorg and its Timbers, by G. H. Foster (No. 2.)</i> ...	332
<i>The 'Local Trade' in Upper Burma, by J. N.</i> ...	334
<i>The qualities of good saws, by A. W. Lushington</i> ...	337
<i>Bürgermeister Krahe, by Sir D. Brandis, K. C. I. E.,</i>	340
<i>Cast Wood (translated from the Revue des Eaux et</i>	
<i>Forêts.)</i>	341

II.—CORRESPONDENCE.—

<i>Fires caused by sparks, letter from C. E.-H.</i> ...	342
---	-----

III.—OFFICIAL PAPERS AND INTELLIGENCE.

<i>Fodder Reserves and Pastures</i> ...	343
<i>Sources of Rubber Supply (from "Kew Bulletin")</i>	349

IV.—REVIEWS.

<i>Report on Forest Administration in the Seypore</i>	
<i>State for 1891.</i>	354
<i>Effect of the time of felling on the production and</i>	
<i>development of coppice shoots.</i>	355
<i>Indian Meteorology</i>	359
<i>Vegetable cultivation in India</i>	361

V.—SHIKAR.—

<i>Camp incidents in N. India, by O. C.</i> ...	362
---	-----

VI.—EXTRACTS, NOTES AND QUERIES.—

<i>Dew, and its action on plants</i> ...	364
<i>Forest destruction and the Russian famine</i> ...	366
<i>Seeds of the Sugar-maple</i>	366
<i>Match manufacture in India</i>	367
<i>State Forestry in America.</i>	367
<i>The largest band saw machine ever made</i> ...	367
<i>White Wax in China.</i>	468

VII.—TIMBER AND PRODUCE TRADE.—

<i>Churchill and Sim's Circular, August 5th, 1892.</i> ...	371
--	-----

VIII.—EXTRACTS FROM OFFICIAL GAZETTES.—

SUPPLEMENT.

<i>Appendix series of the Indian Forester.</i>	
(2) " <i>Podophyllum Emodi</i> " (Reprint of pages	
7 and 8 for substitution.)	

Sa
Bal
sc

THE
INDIAN FORESTER.

Vol. XVIII.] September, 1892. [No 9.

Coorg and its Timbers.

II.

The timbers of the Ghat Forests have not as yet been really tested with a view to discovering which are really valuable. There must be a mine of wealth in the hills facing the west coast but as yet the following kinds alone are exported from Coorg.

Poon *Calophyllum elatum*.

Karri *Diospyros Ebenum*.

White cedar. *Acrocarpus fraxinifolius*.

Agil or Kadgandha. *Dysoxylon binectariferum*.

Teak.

But in addition to these,

Sampigé. *Michelia Champaca*.

Irupu. *Hopea odorata*.

Atha. *Mesua ferrea*.

Halsu. *Artocarpus integrifolia*.

Hebhalsu. *Artocarpus hirsuta* are used locally.

But Noga (*Cedrela Toona*) which grows to a gigantic size, should prove a valuable wood and there must be others in the evergreen forests which, in the event of the kinds at present favoured in the timber markets being worked out, would be worth extracting. Statistics of the quantities of each kind sold are not to be had. There being but one rate for all kinds of wood, all were lumped under one head of revenue but practically the removal of timber by coast merchants has been confined to the five first mentioned species. These have been exploited from what are now the Urti and Kerti Reserves which lie on either side of the Mercara-Cannanore road and extend from the Malabar boundary up the road for about twelve miles.

As might have been expected, in the absence of a working plan, those parts of the forest nearest the main road and the

Kuttampollé river have been cleaned out and purchasers have to go further into the hills every year. The work of extracting the timber is very hard and very expensive. The hills are extremely steep and rugged and render the transport of large logs a work of great difficulty. Elephant draught is used to drag the logs to the bank of the river down which it is floated to near Cannanore and sold there mostly to Bombay merchants. Some idea of the cost of dragging may be obtained from the figures given me by a Moplah engaged on the work. He had hired four elephants, of of which one was a young calf, which was practically of no use. These cost him, hire and keep, Rs. 700 a month. For this he extracted about 360 cubic feet per month per elephant. The calf cost him about Rs. 100, so that his timber was landed at the river side for 8 annas 11 pie per foot. I am inclined to believe these figures are exaggerated but the charges can be scarcely less than 6 annas per foot. The elephants were so badly treated and overworked, that high as their hire may seem to be, I would not give a long life to them, though during the off season for timber they do little or nothing and thus probably obtain an opportunity to recoup their strength ; but having had considerable experience of elephants on timber work some years ago, I should say these elephants would not last long.

I could get no figures giving the floating charges down to the coast. In fact the men with whom I have conversed do not seem to be certain themselves, but it may be one anna to one and a half anna per foot, which would bring the expenditure on the wood to probably 7 or 8 annas per foot, to which must be added the price charged by the Forest Department, varying from 2 annas to 4 annas. Thus, leaving out all profit to the exploiter, timber will cost from 9 annas to 12 annas before it gets to its market.

But the expense of dragging the wood to the river side might be considerably lessened in two ways. One is improving the method of hauling. At present the elephants have no harness. A big hole is made in one end of the log and a very thick, soft rope of fibre is passed through it and a knot tied at its further end. This rope the elephant seizes in its mouth and drags the log alongside itself. To do this the elephant has to partly turn his head and body and, in consequence, loses a very large portion of his hauling power. The mahout walks alongside the animal encouraging and punishing it. This method of hauling timber is slow and so unsatisfactory that much timber which might easily be moved by elephants properly harnessed with saddle and traces and whose mahouts ride them—is left in the forest. I wished to purchase four elephants to shew the Moplahs how to utilise their own to a greater extent but the purchase was not sanctioned.

The other expedient is properly aligning and constructing roads. At present the purchasers are too petty, have not suffi-

cient transport, and are without capital to make roads, and owing to the quantity of hauling power at their command they only fell the smaller trees. This necessitates their going all over the forest to find the trees they require, and thus they would be precluded from making roads owing to the expense involved. Any large purchaser able to move any log met with would be able to confine his fellings to a certain tract and afford to make exits for his timber. All this points to the want of a working plan and undoubtedly some system whereby the fellings in our forests in the Western Ghats can be controlled is needed. Up to the present, the removal of timber has been so small that much damage has not been done by this desultory felling but as the demand from the coast develops, and it appears to be increasing, casual cutting down of trees cannot be permitted. Once a systematic arrangement of fellings has been fixed, the department will take up the subject of roads for the exploitation of timber and we may expect to see the demand rise considerably. Much of the Ghat Forests will, however, never be of use as timber-yielding land. The extract of logs or even poles from the eastern and northern slopes is practically impossible, for the transport would be so tremendously expensive as to swallow up all the receipts. A condition of the market in which timber from the inner slopes of the Western Ghats would pay is not likely to happen, nor is it to be hoped ever will happen. With the outer slopes facing the sea the conditions are different. Along the Malabar boundary the greater number of the forests in that district are private property and are rapidly being exhausted. Indeed, some are now practically worked out and we must expect an increasing demand every year. At present, the whole ghaut boundary for a distance of 90 miles or more, is absolutely unguarded in the rains and has very little protection in the dry season. Owing to the absence of population, the inability to procure the necessaries of life and the tremendous rainfall, which, by filling up the water courses and making each stream a roaring torrent, cuts off all communication with the better inhabited and more accessible parts of Coorg, our Forest guards refuse to live in the ghats during the monsoon. I have grave fears that timber is stolen in the rains along the Malabar border. Our forests are safer where they touch South Canara, as Reserved Forests of this latter district march with our border for some distance and in the N. W. of Coorg, the forests are stunted and contain such poor kinds of timber that the removal of timber would not pay.

I have now attempted to describe the timbers of Coorg and in doing so have given my readers some idea of the forests in which they grow and the prospects of those forests. In a future number, I will endeavour to give an account of the other two important forest products, Sandalwood and Cardamoms.

G. H. FOSTER.

The "Local Trade" in Upper Burma.

In the leases entered into in Upper Burma previous to the annexation, there was always a clause safeguarding certain rights of the population in regard to Teak timber actually required for domestic or religious purposes, *viz* :—

"The inhabitants of the towns and villages are not to be interfered with in the extraction of whatever timber they require for houses, monasteries, and votive trays or platters, nor is any revenue demand to be made on them for timber so used."

Whether or not these rights were immemorial or were of recent creation under the comparatively enlightened reign of Mindon Min is of no importance,—but these privileges were recognised as rights by the British Government at the time of the annexation, and when renewing the leases of the Bombay-Burma Trading Corporation, Limited, or rather when entering into Articles of Agreement and leases under the same for such forests as the Corporation claimed to have the right of working, a clause was inserted to the effect that :—

"The customary rights of the people safeguarded in the leases with the ex-king shall not be interfered with or suspended by the agreement or any leases made under it."

No definition, however, is anywhere explicitly given of the "local trade." The forest rules are dumb on the subject. The nearest approach to a definition is a clause contained in the sub-licenses (or leases) for separate forests granted to the Corporation under the general Articles of Agreement, *viz* :—

"The right or liberty of residents in Upper Burma (on giving notice to the Corporation or its employes of their intention so to do) to fell and take away timber in and from the said forests for use in Upper Burma only and not for export."

There seems nothing to lead any one to believe that sale of Teak timber was to take place to timber merchants, if such a class formerly existed, or for the purpose of exporting the timber to Lower Burma for trade purposes. Since the annexation, however, the privileges of the 'local traders' have been extended to such a degree as to threaten to injure the Government Revenue seriously in the future, although productive of a somewhat considerable increase of immediate revenue.

In Upper Burma the reserved trees are Teak, Thitka, (*Pentace burmanica*), Thitkado (*Cedrela Toona*), Padauk (*Pterocarpus indicus*), Thingan (*Hopea odorata*), Kaunghmu (*Parashorea stellata*). The girdling or killing of these reserved trees is prohibited under the forest rules, but there is nothing to interfere with or prohibit the cutting, felling, extraction and sale of any dead or windfall trees of these kinds, or of trees formerly girdled by villagers previous to the prohibition of girdling on issue of the forest rules under the Upper Burma Forest Regulations.

The export of converted teak timber to Lower Burma forests not worked by lease-holders has for some years now been permitted at an export duty of Rs. 25 per ton. Under a recent executive order, however, the export of timber in the log has been sanctioned from various forests on payment of Rs. 10 per ton beyond the usual amount payable on arrival of timber at a Revenue Station. The result of this is that merchants can buy from local traders in the floating streams up in the Bhamo, Katha and Yeu divisions at about Rs. 12 per ton, and export to Rangoon at rates much below what is fetched at the Auction Sales at the Government Dépôt, Rangoon, even in years when the timber market is not good. The costs incurred in the transactions may be assessed as under :—

Purchase from local traders	...	Rs. 12	per ton.
*Local Revenue at Govt. Revenue Station	..	7½	" "
Floating to Mandalay	...	1	per log.
Export duty	...	10	per ton.
Rafting charges to Rangoon	...	4½	per log.
		—	
Total about Rs.		35	per ton.

That is to say, the timber can be landed in Rangoon about Rs. 15 to 20 per ton cheaper than the milling firms could obtain it if the teak timber, which is undoubtedly the property of Government, were sold by public auction at the Government Dépôt. Government, on the other hand, at present derives only local duty Rs. 7½ + export duty Rs. 10 = Rs. 17½ per ton as revenue in place of about Rs. 35 per ton which might be obtained as the net revenue on auction sales.

In the Shweli Forests the contractor, who by the way, has either intentionally or through a slip, no clause in his contract, which is practically a lease, safe-guarding the customary rights of the general population,—finds that practically all the good girdled timber is claimed by villagers and other residents from the Sawbwa downwards, who insist on being paid well for the transfer of the so-called rights over the timber standing girdled in the forests. Considering that six floating seasons have now gone by since girdling was ruled illegal, the time would surely seem to have arrived for Government to step in and insist on having the full benefit of its proprietary right to all Teak timber.

Of course it must not be overlooked that the maintenance of the local trade system was of great use to Government in keeping at peace a large body of men scattered about in different forest tracts, who might otherwise have given considerable trouble at a most inconvenient time. The assumption by Government of

* It is not in reality so high as this.

its undoubted proprietary rights in regard to Teak would not, however, be likely to cause friction to any considerable extent if the local traders were transformed into contractors working under direct departmental agency as in Lower Burma. To effect this, however, it would be well to prohibit altogether the export of timber in the round from Upper Burma (except, of course, from the leased forests) unless it was bought from a Government Dépôt. This would restrict the sale of timber extracted by local traders for merchants from whom they receive advances, for the amount of converted timber that can be utilised and disposed of within the limits of Upper Burma is not either unlimited or capable of considerable expansion.

Next to the selection of areas for reserves, the task of organising a body of Contractors working by direct departmental agency as in Lower Burma, is that of the greatest importance at the present moment, unless we can be prepared to put in trained departmental contractors to work the leased forests when the B. B. C. leases fall in in 1897 (Pyinmana) 1900 (Chindwin, Yaw) and 1901 (Pyaungshu), their home influence at the India Office—more especially if a Liberal Government should then be in power, may enable them to obtain extensions of the leases to the detriment of the Local Government of Burma. And unless we arrange to commence at once the introduction of the direct departmental working, we shall certainly not be able to raise up an efficient body of contractors at a moment's notice.

Beyond doubt, illicit girdling has taken place extensively throughout the unleased forests of Upper Burma since the annexation, but the divisions are so large and the controlling and executive staff relatively so small, that good control and supervision have not hitherto been possible; it must be recollected, too, that the movements of Divisional Officers are slow, owing to the large police guards without which most of them are not allowed to proceed on tour into the forests in the working season.

To facilitate the introduction of departmental contractors, it seems to me that the export of all teak timber from Upper to Lower Burma should be prohibited except in the case of timber (i) worked out by lessees or contractors who have specific licenses or contracts authorising them to remove the timber to Lower Burma; (ii) bought from a Government Sale Dépôt. This (ii) would practically confine the working of local traders to the supply of *bond-fide* requirements for general local purposes in Upper Burma, and would be a step in the direction of getting them to take up work as Government Contractors, for their market for timber sales would be restricted to the supply of the *bond-fide* local requirements only, as without doubt seems to have been originally intended.

J. N.

at ordinary
g up of the
stated that
• *purposes,*
res special
supply of

I wrote, to
of Messrs.
t Birming-
y, in reply,
le of cut-
tals. If a
sharpened,

given me
to some of
formation I
ackets and
sh Lovett

following
pered in a

a circular
it with the
e cut with

ircular saw
thirty inch
at least be
h cut but
:ter, which

e thickness
by the fol-
the larger
as not vary
t, and logs
; it will be
ar saw of
om 157 to

its undor
 however,
 the local
 direct de
 however,
 timber ir
 the lease
 Dépôt.
 traders fo
 amount o
 within tl
 capable o

Nex
 organisin
 agency at
 the prese
 departme
 B. B. C.
 and 1901
 more esp
 may enat
 ment of t
 to comm
 working,
 body of c

Beys
 througho
 annexatic
 executive
 vision ha
 that the
 large pol
 to procee

To f
 seems to
 Lower B
 (i) worke
 or contra
 Burma ;
 would pr
 supply of
 Upper B
 them to t
 for timbe
vide local
 originally

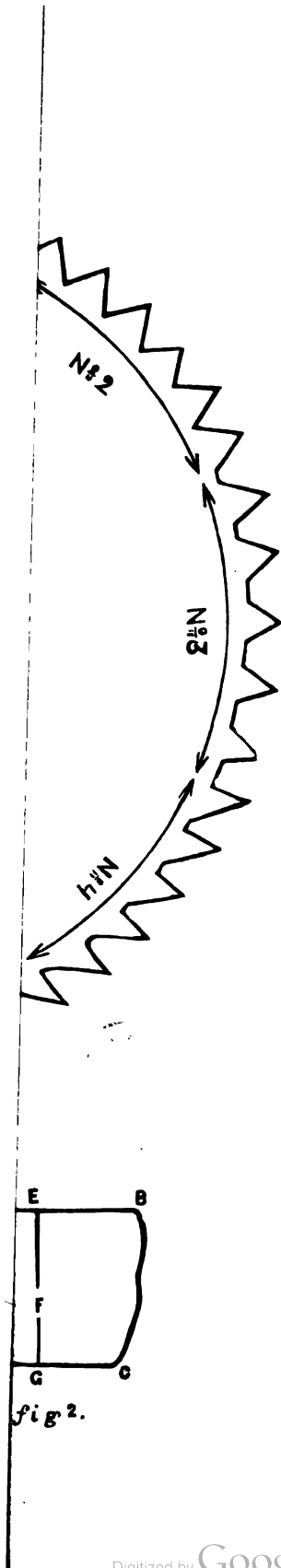

fig 2.

The qualities of good Saws.

I believe it is not an uncommon idea in India that ordinary English saws cannot be used in sawmills for the cutting up of the hard woods of India. One Conservator has officially stated that '*few if any, sawmills in Europe are suitable for our purposes, as our timbers are so hard. The matter requires special consideration by experts in this country, and the supply of special plant.*'

Believing that this statement was scarcely correct, I wrote, to assure myself on the subject, to the well-known firm of Messrs. Walsh, Lovett, & Co., who have offices or workshops at Birmingham, London, Liverpool, Sheffield, and Calcutta. They, in reply, state that "*any best quality English saws are capable of cutting all woods, no matter how hard, and even metals. If a good quality saw is well tempered, properly set and sharpened, with a suitable tooth, it must give satisfaction.*"

They have also, in reply to my questions, kindly given me the following information which may be of interest to some of your readers. The parts marked in brackets contain information I have collected from elsewhere, the parts outside the brackets and in italics being the information given by Messrs. Walsh Lovett & Co.

Temper.—Best saws are usually tempered in the following manner: first hardened in whale oil, and then tempered in a furnace to a light or greyish blue colour.

Shape of saw.—A vertical saw is better than a circular saw for cutting large timber, as any size can be cut with the former, but there must be a limit to the size that can be cut with a circular saw.

[M. Thiéry says that 1.50 metres is the limit for circular saw diameters, *i. e.*, approximately 60 inches. This gives a thirty inch radius; but as he says that one-sixth diameter must at least be deducted for the collar, this leaves only 2 feet 1 inch cut but Messrs. Walsh Lovett & Co sell up to 78 inches diameter, which leaves a 2 feet 4 inch cut.

[If the circular saw is of very large diameter, the thickness of the blade becomes very great; and it will be seen by the following table that the proportion increases with the larger saws. With a vertical saw the thickness of the blade does not vary much more than from 80 to 120 thousandths of an inch, and logs of 4 or 5 feet diameter, can be cut with them, whereas it will be seen that to cut a log of 2 feet diameter with a circular saw of 60 inches diameter the thickness of the saw must be from 157 to 200 thousandths of an inch thick.

Table of thicknesses used for circular saws by the firm Mongin and & Co., Paris, as extracted from M. Thiéry's Traité des Scieries, and converted into English measurements.

Diameter of saw in inches.	Thickness of saw in thousandths of an inch.	Diameter of saw in inches.	Thickness of saw in thousandths of an inch.
8	27 to 43	36	94--118
12	39 ,, 51	40	98--126
16	55 ,, 66	44	110--130
20	59 ,, 70	48	118--145
24	70 ,, 90	52	126--150
28	80 ,, 110	56	142--165
32	90 ,, 118	60	157--200

[It goes without saying that with the thick cut the wood is merely wasted.

[The only way to cut logs of say 4 feet diameter with a circular saw would be to cut half way through on one side, and then turn the log round and cut half way through on the other side. Thus if A. B. C. D. is the cross section of the log, and E.F. is the cut made the first time, the log must be turned as in fig. 2, and the cut F. G. made. This arrangement, however, never works neatly.

[Another reason why vertical saws are preferable to circular saws for large timber is because the former are held in position at both ends whereas if the latter are of large diameter they are apt to wobble and bend, and so become over heated and may crack or fly.

[Circular saws are better than vertical saws for wood of small dimensions as the cut is finished more rapidly the motion being continuous instead of alternating.]

Teeth.—The best teeth are the "London" (No. 9) "Gullet" (No. 8) and "Mill Saw" (No. 4) for hard wood. A smaller tooth should be used for soft, than for hard wood.

[The "space" is the distance between two consecutive teeth, and for oak a space of $1\frac{1}{2}$ inches is generally given.

[Thiéry gives the following formula for calculating the "space" to give, with the following notation.

L = length of plunge of saw frame.

h = height of a given log.

j = propulsion for each plunge.

m = the ratio between a cubic foot of the wood, and a cubic foot of its saw dust.

a = the space.

K = a co-efficient.

[Then $a = \frac{4 m h l}{K L}$, K for the three teeth above mentioned is $\frac{55}{69}$, $\frac{34}{91}$, and $\frac{81}{70}$, respectively.

[Could any of your readers obtain the ratio "m" for the more important woods, say Sal, Teak, Ebony, Dalbergias, Terminalias, Xylia, Anogeissus, Hardwickia, Pterocarpus, Soyimida &c. ? The best way to do this is to have a box made so as to contain exactly one cubic foot of sawdust, and allow the dust to fall into it as sawn: for the dust must not be pressed down. Then the box and dust should be weighed, and the weight of the box without the dust deducted.]

The setting.—[The set is the outward bend given to the points of the teeth; first one right, and the next left, then right again, and then left again and so on. It is to prevent the wood from pressing against the blade, which would otherwise become over heated from friction.]

The setting is according to the thickness of the blade, just enough to clear itself. The more set put on takes more power to drive, and also wastes the wood.

[M. Thiéry says that from experiments he found that the best set for steel blades of vertical saws of any thickness was $\frac{4}{10}$ millimetres, i. e., approximately 16 thousandths of an inch, on either side of the axis of the blade. Thus a blade of 86 thousandths of an inch thickness was in its best working condition, when the set gave a cut of 118 thousandths of an inch; and a blade of 102 thousandths of an inch was best set with a cut of 134 thousandths.

[For circular saws, he advocates 1 millimetre or about forty-thousandths of an inch set for hard wood, and half the thickness of the saw for soft wood. So the total thickness of the cut for hard wood with a 36 inch diameter saw would be from 134 to 158 thousandths of an inch; whilst for soft woods, it would be from 141 to 177 thousandths.

A. W. LUSHINGTON.

Bürgermeister Krahe, Prummern, near Aix-la Chapelle.

Some of the Coopers Hill Forest students, who accompanied me on my tour in 1889 and 1890, may remember the visit which we paid to the osier beds near Geilenkirchen, they may also recollect our amiable guide, and the pleasant and instructive hours which we spent among his willow plantations and at his house, before driving across country to Jülich. In March last he died at the age of 66. Bürgermeister Krahe had charge of the commercial lands of a number of villages in the undulating plain which is traversed by the rivers Roer and Würm, feeders of the Maas (Meuse). The chief portion of these lands consisted of meadows on black but very inferior soil, yielding at the outside 29 shillings per acre per annum. From time immemorial there had been osier beds on the low lands near these rivers but they were not well managed and had gradually been abandoned. About 1860, there were barely 60 acres of osierbeds in that part of the country. Krahe conceived the plan of resuscitating this branch of industry and his efforts were crowned with marked success. In order to gain experience he rented suitable lands and established osier beds on his own account. The results were most satisfactory, and these results enabled him to induce the communal councils of the villages in his charge to consent to plant up the communal lands. In this manner, the village of Würm, for instance, has realized from its meadows, converted into osier beds, during the years 1869 to 1884, an annual income per acre of 188 shillings gross and 124 net. The villages of the neighbourhood soon followed suit, and in 1885 the osier beds in the tract of country here adverted to, amounted to 1630 acres, partly private, partly communal property.

Krahe was indefatigable in making experiments to ascertain the system and varieties of willows most suitable for the soil and climate of his district, their treatment and their protection against beetles and other enemies. A walk with him through his osier beds, was most instructive, for he was intimately acquainted with the history of each field. He had learned from failures, where mistakes had been made, as well as from good success where everything had gone on well.

The result of his experience be embodied in a small hand book of osier beds culture (*Lehrbuch der Korbweiden Cultur*) which appeared first in 1878, and of which several editions, the fourth in 1886, have been published. It is the best treatment of the subject in the German language.

Krahe was an extremely modest and amiable man. His name will long be remembered in the country, for the economical development for which he has done so much.

Bonn, July 1891.

DIETRICH BRANDIS.

Cast Wood.

(From the Revue des Eaux et Forêts.)

We have before us a curious product and we believe also an altogether new one. It is a slab of a few centimetres long as many wide and half a centimeter thick formed of a black substance, well polished on every face, unbreakable, inflexible, difficult to cut with a knife. It cannot be a metal for the fracture has not the lustre nor any of the usual characters of metals. Can it be wood? The outward appearance resembles fairly that of certain exotic woods, ebony for instance, but more careful examination reveals the presence of none of the constituent elements of wood.

This strange substance has been obtained by Messieurs Lenior mayor of Semur and Bizouard electrical engineers, who manufacture it from sawdust or wood shavings submitted to the combined action of a high temperature and strong pressure and shut off from all contact with the oxygen of the air in a crucible hermetically sealed.

Although the original idea may be extremely simple, there are certain methods of utilizing the various elements and forces employed which are kept secret by the inventors, who have given to the product, the name of 'cast wood.'

Whether this name is justifiable, whether there is not rather dissolution than fusion, is not important; a fact of first importance has been none the less accomplished: sawdust introduced into a crucible can be transformed there into a liquid which on cooling furnishes a solid substance presenting remarkable properties.

It is not moreover a pasty mass which is produced inside the crucible, it is at some time or other a genuine liquid, for the impression of medals placed at the bottom of the crucible can be reproduced in their smallest details with remarkable perfection. It must not be omitted to state that the mass on cooling does not contract in the least which renders it eminently suitable for moulding. As to the possible commercial value of the discovery, it is certain first of all that 'cast wood' can be utilized. It can be employed for making all sorts of ornaments, squares, rulers, printing type, and moulds of all kinds. If it becomes possible to cast sufficiently large plates of it, it might equally well be used in cabinet work; the black colour is, it appears, easily modified, and the employment of pieces of different colours may produce quite new effects in the manufacture of furniture.

The original material costs nothing or next to nothing. Up to the present, only the sawdust and shavings of oak have been employed and which had already been used in the preparation of so called solution of tannin, but the inventors are satisfied that the same results could be obtained with the refuse of wood of any species whatever.

There then remain to be considered the construction and working of the machinery and there does not appear to be any exceptional difficulty about these. Messieurs Lenoir and Bigouard have drawn up complete plans of a mill of which the production in cast wood would be specially employed in the making of printing type.

We wish good luck to the new industry of "Cast Wood" which seems to us likely to succeed and of the progress of which we will keep the readers of the '*Révue*' informed. The object of the present article has been merely to make known a curious fact which has been made use of by careful observers in a word:— a genuine invention.

II.—CORRESPONDENCE.

Fires caused by Sparks.

DEAR SIR,

Under the above heading there was an article in your April number initialled E. G. C. Perhaps the following facts will interest him. One night some years ago while travelling by country cart from Palamcottah to Tuticorin, I walked ahead of my carts for some miles; and feeling hot, sat on a heap of metal collected for the repair of the road, and having nothing better to do, began to throw the bigger pieces of metal at a boulder a few yards distant. On missing the boulder and striking the broken stones imbedded in the ground all around, I noticed sparks. I then got up and threw, or rather bowled, some large pieces of metal along the road and found that at every ricochet bright sparks were emitted, obviously caused by the stone thrown striking the old metal on the road, which like the metal collected, was, I think, lime stone, and no doubt, contained a good deal of flint. Sparks also appeared when two pieces of the metal were struck together by hand, but not so often, or so bright as when a stone was bowled over the metalled road, with force. In my humble opinion, any stone sufficiently hard and homogeneous will emit sparks, provided it is not too brittle, for the sparks are merely due to intense heat engendered at the point of impact by the concussion.

C. E.—H.

III.—OFFICIAL PAPERS & INTELLIGENCE.

Fodder Reserves and Pastures.

In our No. for September 1891 we gave some account of the (then) recent circular of the Government of India on this subject. We have now received copies of the correspondence about it between the Madras Government and the Government of India which we reprint as likely to interest some of our readers. The Madras Government says :—

2. The Resolution is forwarded to the Government of Madras for information only and it is not therefore clear whether it is intended that action should be taken in this Presidency in accordance with the instruction contained therein. I am moreover, directed to say that His Excellency in Council doubts whether he apprehends quite clearly the wishes of His Excellency the Governor General in Council in regard to certain very important points which are dealt with in the said Resolution, and I am further to indicate how far the forest policy of this Government is at present in accord with that outlined in the order under reference or will in future be brought into consonance therewith.

3. The Government of India Resolution defines what are "pastures," "fodder reserves," and "forests" properly so called, and it appears that its main object is to set on foot in the provinces, under the direct management of the Government of India an analytical examination of each district in view to ascertaining the extent to which the efficiency of agricultural operations can be secured by the existence of such areas. His Excellency in Council assumes that in dealing with this question it is understood that there exist large numbers of cattle which are of no use for the purposes of agriculture except in furnishing a small quantity of manure, and it is presumably the intention of the Supreme Government in seasons of great draught to support as far as possible, those cattle that are of use to the agricultural population by throwing open to them the forest reserves free of charge, while restricting the admission of useless animals by the imposition of fees. I am to say that, if the above interpretation of the Government of India Resolution is correct, the Madras

Forest Officers can be instructed to report the areas of reserves in which grazing or fodder is available in each district and to estimate the number of cattle that can be supported from these sources, firstly, in an ordinary season, and secondly, in periods of great drought. His Excellency in Council is, however, convinced that in the latter seasons it is quite impossible to keep alive *all* the cattle in each district by means of the fodder and boughs of trees which can be provided from the forests, pastures, and fodder-reserves under Government control in each such locality, and in this connection I am to intimate that this Government entirely concurs with the remarks of the Government of the North-Western Provinces and Oudh in regard to the pressure of cattle upon the means of subsistence. His Excellency in Council, moreover, fears that estimates of the requirements and capabilities of any tract in respect of fodder-supply would not be reliable, and would, therefore, be of little value, and desires me to point out that orders have already been issued in this Presidency directing the conservation of all waste lands at the disposal of Government, which are worth taking up for forests, for plantations, or for fuel and fodder reserves. I am accordingly to say that this Government has done and is doing all that is possible to improve the fuel and fodder-supply of the country, and doubts whether the compilation of a statistical analysis would in any way improve the position. In this Presidency, separate schemes for the further reservation of forests are being carefully prepared for the various districts, and the general question of providing fodder, fuel, and timber for the agricultural population

G. O. No. 844, dated 29th
October, 1890.

was fully discussed in the marginally-noted order, a copy of which was communicated to the Government of India. Of the conclusions arrived at in that order and of the policy therein enunciated, His Excellency the Governor General in Council has on several occasions expressed unqualified approval, and I am to say that, in the opinion of His Excellency the Governor of Madras in Council, it could hardly be urged that the requirements of this Presidency in connection with the maintenance of a fodder-supply had not been seriously investigated. I am, however, to add that in the event of the Government of India desiring that an analytical examination of this nature should be instituted in Madras, orders to that effect will be duly issued by this Government.

4. The exact purport of the instructions laid down in paragraphs 7 and 8 of the Government of India Resolution is not understood. It is first declared that the management of Government reserves "must be conducted on mercantile principles" [paragraph 7], and then that the system adopted for their control should be such as to exclude, as far as possible, all interference on the part of "subordinate officers" [paragraph 8]. Taking these two orders together, the meaning seems to be, that the

reserves are to be made to yield the largest possible revenue by putting up to auction the right to their use, and by entrusting their management to the successful bidders; for it is clearly impracticable to prevent interference by subordinate officials, if the supervision of these areas is retained by the Forest Department. In reviewing the Forest Administration Report of this Presidency for the year 1889-90 the Supreme Government accepted the view of this Government that the initial object of imposing a fee upon grazing was not to increase the revenue, but to restrict the number of cattle feeding in the reserves, while it was at the same time declared that there was no objection to selling by auction the right of pasturage on grass farms. I am accordingly to say that the intentions of the Government of India in the orders contained in paragraphs 7 and 8 of its Resolution under reference are not clearly apprehended.

5. In paragraph 9 of the Resolution it is declared that except in years of great drought "fodder-reserves" must be "absolutely closed against grazing, the fodder being cut and collected." The term fodder is in the preceding sentence stated to include bushes and trees edible by cattle, and it is presumably intended that this species of fodder should be similarly treated. I am to say that in the opinion of His Excellency the Governor of Madras in Council, the above declaration goes somewhat too far. The fencing in and closure of reserves, where good grass can be grown, would, without doubt, result in a larger yield of fodder and in a consequent increase of revenue; but His Excellency in Council considers that such reserves should occasionally be thrown open in blocks to grazing, in order that the ground may be manured by being grazed over before being again closed for growing grass crops. The Government is, moreover, of opinion that only in season of great drought would it be either practicable or necessary to supply the lopped boughs of bushes or trees as fodder for cattle. I am, however, to add that in the matter of cutting and stacking fodder for sale, the Government of Madras is entirely at one with the Supreme Government, and to state that orders have recently been issued that this course should be adopted wherever possible. His Excellency in Council is at the same time clearly of opinion that the fodder so stacked should be sold as soon as possible and not stored against a future season of drought.

6. In this Presidency, fodder reserves are regarded as most useful for the supply of fuel, for this class of produce usually grows on the same areas as fodder, and by far the largest income from reserves of this nature is to be made by the sale of fuel from day to day under proper forest management. I am to observe that the Government of India does not appear to have noticed fodder reserves from this stand-point.

7. Lastly, I am to express the regret to His Excellency the Governor in Council that he is unable to agree with the Supreme Government in the views set forth in paragraph 13 of the above Resolution. If an area is constituted a Reserved Forest, it should, in the opinion of His Excellency in Council, be under the management of the Forest Department, and under the system adopted in this Presidency it would always be so managed by the Collector of the District and his Forest Assistant.

8. In conclusion I am to say that the Resolution of the Government of India will not be communicated to the Board and Conservators of Forests pending the elucidation of the questions raised in the foregoing letter.

To this the Government of India replied:—

The remarks made in the letter from the Government of Madras, have been considered by the Government of India, and in compliance with the request therein contained, I am directed to offer some further remarks regarding the subject discussed in the Circular Resolution of the Supreme Government, dated the 15th July 1891. The Resolution was forwarded to the Madras Government for information only, and with the view of enabling His Excellency the Governor in Council to compare the policy of his Government with that adopted by the Government of India for the management of State lands; but the Government of India are glad of the opportunity of further discussing the subject, and of shewing how far their views harmonize with those of the Madras Government, which has taken so strong a lead on this question.

2. The Government of India are in accord with that of Madras in recognizing the serious administrative difficulty which is caused by the existence of large numbers of unnecessary and unprofitable cattle, alike useless for agriculture and breeding purposes, and in conjecturing that these excessive herds are allowed to exist only in places where little value is placed on fodder because it is supplied *gratis* from State lands at the expense of the general public.

3. The Government of India are prepared to approve any policy suitable to the circumstances of the country, which would prevent, in the interests of agricultural prosperity, the further increase of such useless herds, and which would restrict as far as possible the area on which they are admitted to graze. They are disposed to believe that the most practical means by which this result can be obtained will be found in the exaction of a payment for fodder obtained from State property. This policy was kept in view when, in reviewing the Madras Forest Administration Report for 1889-90, the Government of India expressed approval of the principles laid down by His Excellency the Governor in Council for the management of pastures and grass lands; and the same

policy underlies paragraphs 7 and 8 of the Government of India's Resolution now under discussion.

4. The statement in paragraph 7 of that Resolution that the management of Government lands should be conducted on mercantile principles, was meant to convey that a fair market price should be exacted for the use of the produce, sufficient to prevent the enjoyment of undue indulgences by a limited section of the community at the expense of the general taxpayer, but it should have been explained that it was not intended that the highest money value should invariably be realized. The Government of India, however, in laying down this principle desire to leave the practical working of it entirely in the hands of Local Governments, who may decide, according to the conditions of each case, the manner, means and rates according to which grass and other fodder can be most economically and equitably disposed of.

5. The Government of India have abstained, in view of the difficulty of distinguishing agricultural from other cattle from formally recognizing the principle that in years of drought the reserves should be thrown open to agricultural cattle free of charge; but they have, at the same time no intention to fetter the discretion of Local Governments in remitting or reducing all charges for every class of cattle in the event of great droughts.

6. The statement made in paragraph 8 of the Government of India's Resolution is that the system of management, *i.e.* the treatment of pastures (not the system of control), should be such as to exclude, as far possible, all interference on the part of subordinate officers. It is of course understood that, so long as there is to be control at all it must be exercised by subordinates of either the Forest or Revenue Departments, or by contractors or middlemen. The term "management" was however used in the somewhat technical sense in which it is employed in forestry and was intended to mean the general rules or system prescribed by the more responsible officials for the treatment of pasture and fodder-land. The term was not intended to include the executive control under which the system or rules were to be carried into effect. In this view the "management" or system under which the utilization of pasture or fodder is directed should, as in the case of wood-forest, be based on a pre-considered plan which would virtually preclude subordinate officers from deciding on their own arbitrary judgment whether certain areas are to be thrown open, or to what extent they shall be utilized.

7. The Government of India are disposed to consider that pasturing is the most wasteful way of taking a grass-crop off the ground, and should not as a rule be allowed in fodder-reserves. If this view is correct, the practice would become doubly objectionable in years of scarcity; at all events until the main crop,

has been gathered by hand. When this has been done, the cattle may still find between thorns, stones, &c., some blades of grass which could not otherwise be utilized.

Under certain conditions it will undoubtedly be useful, as proposed by the Madras Government, to throw open fodder reserves periodically for a limited period of a few months, after the main grass-crop has been harvested.

The Government of India agree in the views expressed by the Madras Government that all stacked fodder should be disposed of as soon as possible, and that, whenever feasible, the grass-crops should be sold standing. They concur also in the view that bushes and boughs of trees should be utilized as fodder only in seasons of drought, though there may be exceptional fodder-reserves which, under a pre-conceived plan, may yield an annual or periodical supply of branch-fodder. There may also be cases necessitating on the part of Government, storage of fodder of military purposes, but in such cases, the fodder should be pressed and baled. His Excellency in Council takes this opportunity to draw renewed attention to the importance of encouraging the growth of fodder-bushes and fodder-trees, which can withstand drought, in tracts where grass fails in dry seasons.

The Government of India have not laid down any rules in regard to the management of fodder-reserves, and merely ask that their treatment, which must vary in different localities, should be studied.

8. As regards paragraph 6 of your letter under reply, the Government of India are fully aware that in most cases the same areas produce both fuel and fodder and frequently timber as well; but as a rule the production of the one class of produce is the main and the other the accessory purpose, according to which the reserve is classed. A plan of management must naturally consider each purpose at its full value.

9. It is important to remember that the use of the term "forest" does necessarily imply that a tract thus designated should bear trees. The management of some forests need not therefore require any special knowledge of silviculture. But the Government of India have no objection to offer to the decision of the Madras Government that all reserved forests, whether they are classed as wood, pasture, or fodder-reserves, should be managed by the Forest Department; and, though there is nothing in the legal constitution of reserved forest necessitating such a decision, the Government of India entirely agree that the constitution of the Forest Department makes it in most cases the most suitable agency for the management of all State domains of the kind dealt with in this Resolution.

Sources of Rubber Supply.

Para rubber is the produce of *Hevea brasiliensis*, Muell. Arg, a tree belonging to the natural order Euphorbiaceæ. The rubber is obtained from incisions cut through the bark, from whence the sap trickles into small bowls and is finally cured by being ladled on to a paddle-shaped implement and held over a stone in which Urucury Nuts (*Maximiliana regia*) are burnt as the fuel. In Museum No. 1., Case 94, will be found a fine series of articles used in collecting and preparing this rubber for export, and also numerous samples of the rubber. In 1891 the estimated export of Para rubber amounted to 17,700 tons of which 600 tons were imported into this country.

A sample of rubber from *H. brasiliensis*, grown at Mergui, India, was reported upon in this country in 1889 as worth 1s, 11d. per lb.

Ceara rubber or " Ceara Scrap " is afforded by *Manihot Glaziovii*, Muell. Arg, a tree native of South America and belonging to the natural order Euphorbiaceæ. The imports of this rubber into this country amounted to 180 tons in 1891. In Case 96, Museum No. 1. will be found samples from Brazil, and also from plants introduced into Ceylon, Zanzibar, and Natal.

Mangabeira or Pernambuco rubber is extracted from a small tree (*Hancornia speciosa*, Gomez) of the natural order Apocynaceæ. Specimens of this rubber are shown in Case 72, Museum No. 1.

The principal source of Central American rubber is *Castilleja elastica*, a large forest trees of the tribe Artocarpeæ of the natural order Urticaceæ. It affords the Ule of British Honduras as well as Nicaragua, Guatemala, Mexico, and Guayaquil rubbers. The total imports of Central American, West India, Columbian, Carthagenia, and Guayaquil rubbers during the year 1891, amounted to 100 tons. See case 100, Museum No. 1.

Esmeralda of Guiana may perhaps be afforded by *Hevea* sp. or is *Sapium* sp. of the natural order Euphorbiaceæ.

Columbian India rubber and " Carthagenia " are one and the same thing, as is pointed out in the Kew Bulletin, 1890, page 149. The tree yielding this rubber is *Sapium biglandulosum* of the natural order Euphorbiaceæ, a widely spread and variable species, it is also the source of Touckpong or Cumakaballi rubber of British Guiana. Case 96, Museum No. 1 contains specimens of these rubbers.

Assam rubber is the produce of *Ficus elastica*, a large tree of the Artocarpeæ tribe of Urticaceæ. The imports of Assam and Rangoon rubber (also from *Ficus elastica*) amounted to 350 tons in 1891. Specimens may be seen in Case 99, Museum No. 1.

Borneo rubber is afforded by species of *Willughbeia* and *Leuconotis*, allied genera of the natural order Apocynaceæ (see Kew Report 1883 page 43). 200 tons of this rubber were imported into this country during the year 1891. Samples will be found in Case 71, Museum No. 1.

African rubber is furnished by several species of the genus *Landolphia*, woody climbers of the natural order Apocynaceæ. The best quality from the Zanzibar coast is derived from *L. Kirkii*. Two other species, *viz.*, *L. florida* (the chief source of Mozambique rubber) and *L. Petersiana* are also sources of the East African supply.

On the west coast *L. Owariensis*, which has a very wide distribution, is the principal species furnishing Congo and Sierra Leone rubbers. *L. florida*, which occurs on the east coast, and *L. Mannii* also affords part of the West African supply. Liberian rubber is perhaps in part afforded by the "Abba" tree (*Ficus Vogelii*), of the Artocarpeæ tribe of Urticacææ, and has already been fully discussed in the Kew Bulletin for November 1888 and May 1890. Messrs. Hecht, Levis, and Kahn give the following statistics concerning these rubbers for 1891, *viz.*:—African imports, 4,350 tons; Mozambique, 380 tons; Madagascar, 300 tons. Case 76 Museum No. 1, contains samples of these rubbers.

The following review of the sources of rubber supply from the commercial side has appeared in the Indian Rubber and Gutta-Percha and Electrical Trades Journal, January 8th, 1899.

There are merchantable in New York between 30 and 40 different sorts of India Rubber, the varieties determining the selection by manufacturers in the purchase of stocks, says I. A. Sherman in the 'Rubber World.' Of course, rubber in all its variations is essentially the same, differing somewhat in the same degree as the pumpkin in South Dakota from that in New England—one large and another small, one with little flavour and the other richer in food qualities. The difference between sorts of rubber, however, is due in large measure to the methods employed in gathering the sap. It happens that the natives of the Amazon Valley have always taken pains in the curing of rubber. While climatic conditions in that country, may have had their influence upon the character of "Para" the condition in which this rubber is exported has become a prime factor in making it a favourite with manufacturers. On the other hand, some of the African sorts are so full of bark and stones as to make them almost unfit for use. At one time "Assams" were almost unmarketable in New York, the price sinking as low as 10 cents per pound, and not wanted at that. One firm, after long experimenting, discovered a chemical solution in which the rubber was washed, the process being that the bark and other impurities absorbed the chemicals, making them so heavy that they separated from the gum and fell to the bottom and away. This company made a fortune in a moderate space of time; but they put up gradually

the price of Assams, from the fact of their creating a demand for that sort of rubber, until the profits became comparatively small, when they disposed of the privilege of washing to some leading rubber-men who use the process at the present day.

Para rubber is more largely consumed in the United States than any other. It may be noted, also, that the larger share of the rubber exported from Para comes to this country. There are three grades—fine, medium, and coarse. Fine Para is the standard by which all other grades are measured; it brings the best price and probably is more used than any other. Should it become irregular in quality in the operation of curing over the smoke of palnuts—as when little strips of virgin gum occur in the grain—it is called “medium,” and its price is lessened by a cent or two per pound.

The “coarse” is imperfect, being composed of the scrapings and refuse of the fine sorts, and sells for about two thirds of the price of the better grade. It shrinks considerably, having much water in it and the importer generally is in a hurry to turn it over to the manufacturer. There are again many variations in Para Rubber coming from different localities on the Amazons, this subject is involved in some obscurity but the best rubber is supposed to be found on the River Purus, a tributary of the Amazons, having its source in the Andes. Brazilians, however, are apt to believe that the locality of the best sorts is unknown to Americans, and possibly the Purus may not be the locality.

There comes from Peru, at the sources of the Amazons, and its tributaries, a rubber resembling the Nicaragua sheet and called Cancho. This rubber is very wet and consequently shrinks very much, which is a serious drawback. It is considered a good strong rubber, and it is utilized to a considerable extent by the boot and shoe manufacturers.

Of Ceara rubber, there are three grades, numbered one, two and three respectively. It is called a “mule gum” the significance being that it is neither one thing nor the other, it being so deficient in elasticity as to cause some to argue that it is not rubber. It is a very dry rubber, its gathering being peculiar. The tree is incised at the beginning of the dry season, and as gum oozes from the wound it forms on the outside of the bark, to be pulled off at the end of the season. The gathering of this rubber seems to be on the wane, for every year there is an extensive migration of Ceara people to Para, bound for the forests of the Amazon.

From Bahia and Pernambuco, in Brazil, comes a rubber of a different grade from that of Para. It is cured with alum and salt water. The Pernambuco comes in sheets, and is of a yellowish white tinge. That from Bahia is not good, and comes in round balls. The principal objection to it is that it is very damp, entailing a large loss to the importer from shrinkage.

Of Mangabeira rubber, there are three grades, very similar to Bahia and Pernambuco sorts. A grade that has a red look is considered superior, and sells for 5 or 10 cents per pound higher than the others.

From Central America comes a variety of rubber, distinctive in name, theoretically, but owing to the lines of transportation centering at Greytown, and the trans-shipment at that point to New York, there is much confusion, one sort often getting substituted for another. The Pacific mail steamers gather also different varieties at Panama with the same confusion. That which comes from Nicaragua is called Nicaragua "sheet" and "scrap." The latter comes in pieces about 2½ feet long, weighing from 10 to 40 pounds. In the gathering of rubber in the forest, around the cuts in the tree a residuum is left which is given to the man as a perquisite and this forms "scrap." As in the peculiar mode of gathering, it is very dry, there is little loss in shrinkage, and this quality makes it a favorite with manufacturers. It contains some bark, but not so much as the "sheet." The sheet, after it is milled and washed, is the same rubber as the "scrap." Both are cured by the use of a vine from which a soapy [alkaline] substance is formed.

There is another grade which comes from Central America containing a considerable amount of ashes, due to its being smoked over the latter. It comes in thin sheets ¼ to ¾ inch thick. It is a dry rubber, there not being so much loss in shrinkage, but it is not so firm as the other grades, and it is difficult to work. There also comes from Central American ports a rubber which is chiefly grown in New Granada, and is called "Carthagena strip." It is from 1½ to 2 inches thick and there is a great deal of sand and dirt in it. It is a black, tough, rubber.

Honduras furnishes a great deal of rubber of the Tuno sort which is found in many other sections of Central America. Guatemala ranks low in the American varieties, containing a resinous substance. It comes in sheets pressed together. There is a rubber which comes from Angostura as good as Para. When cut it is found to contain little spots of white as large as a pea. Tuxpan, Mexico, once sent a fine grade of strip rubber but as the trees have been destroyed by cutting them down instead of tapping for rubber, the imports from there are now very small. The rubber is gathered by scraping from the bark.

Guayaquil comes in large flakes or lumps of a whitish colour in the best sorts, the inferior sorts being porous and exuding a black liquid which stains the knife and hands. As in a great many Central's the name is often confounded with the sorts.

Esmeralda comes from Guiana, is strip rubber, and is also made into "sausages." Some brokers are of the opinion that very little of the real Esmeralda finds its way to America, it being almost indistinguishable from other grades. It brings a

high price. Certainly, little of it finds its way to Europe, brokers not quoting it there. A great deal of the rubber gathered in Columbia finds its way to the Amazons and Para.

In rubber from Asia the Assams probably take the lead, and are rated above coarse Para in price. There are three or four grades, the lower ones being very dirty and all of them requiring much washing.

There are two grades of rubber from that source one was first called a gutta, on account of its geographical location, but this error was a palpable one and soon corrected. It is a white, soft porous or spongy rubber, the pores being filled with salt water or whey. The better grade is a fair rubber, but the second grade is often, when cut, almost as soft as putty and practically worthless.

Of Africans there are many varieties. The favourite sorts come from Madagascar. The pinky sorts come in the shape of round balls, weighing $1\frac{1}{2}$ to 4 pounds. It is not so strong as fine Para. There is always a good demand for it and it is rarely found in store being sold to "arrive." This sort comes from Tamatave. There are two or three variations in quality of Madagascars, but the grade called "black" comes from Majunga, is exported in small balls, and has a dark colour when cut.

From the West Coast of Africa there are many varieties, the best coming in the shape called "thimbles," which are square pieces one inch each way. The rubber is very dry, and is in good demand by mechanical goods manufactures. It is very strong rubber, and naturally has little shrinkage. Tongues are shaped as their names indicate. There is a considerable shrinkage, but it is a very good rubber about $1\frac{1}{2}$ inches in diameter. It cuts white, and is fairly firm.

Congo ball is made from small strips of rubber and rolled into balls, from 1 to $2\frac{1}{2}$ inches in diameter. It is a firm and very elastic rubber, but there is more or less bark in it, and as manufacturers do not always have proper machinery to exclude it, they do not buy readily.

Sierra Leone comes in balls 3 to 4 inches in diameter, and is a very fair grade of rubber. It has a considerable demand from boot and shoe and mechanical goods men. Like all West Coast rubbers it reaches us by way of Hamburg or Liverpool.

The finer grade of Mozambique is called "white ball." It resembles Congo ball in appearance, and comes in about the same shape. "The red ball" is mixed with a reddish bark, and will be found filled in the centre with bark. The rubber is then called "unripe Mozambique," and sells for 10 cents less per pound.

From Liberia comes a lump rubber. There are three rivers in Liberia from which rubber is gathered, but it is all assembled at the common mouth and the grades are not kept separately, making a class of rubber which is very variable, and therefore disliked by manufacturers.

There is, on the whole, a growing tendency towards the use of Africans, and in this is a true check on the price of Para. In Centrals there seems to be a falling off in the production consequent upon a scarcity of labour, which has been from time to time drawn into internal enterprises. In Europe, the stocks of African are always larger than of Para, and a steady growth is very noticeable.—(*Kew Bulletin.*)

IV—REVIEWS.

Report on Forest Administration in the Jeypore State for 1891.

The total area of the Jeypore State is 14,465 miles. Of this almost two per cent, 278 sq. miles, is the area under Forest management, though only a portion of this is demarcated and reserved. The settlement is, however, proceeding, and the more strictly preserved area will increase.

The most interesting work in this State is probably to be found in the sand-binding operations. Panni grass (*S. Sara*) has been planted with satisfactory results in lines ten feet apart, the plants which are put in with as many roots as possible and in rainy weather, being one foot apart in the lines. *Orphanthera viminea* also helps in fixing the drifting sand and it succeeds best when sown near the grass. Several other species have been tried with varying success. The arid climate and wild animals conspire to render artificial reproduction a difficult matter.

Fire protection is easily managed by the permanent Forest establishment without any extra cost, and 107,000 acres escaped burning during the year under review. There were no failures.

The growth of natural seedlings suffers from a variety of causes, but is said to be making some progress. The browsing of goats and camels has been prohibited over about 61 per cent. of the total area and the result is a marked improvement in the vegetation. The grazing of cattle is, however, rather heavy, only about 7 per cent. of the area being closed for the whole year. A scarcity of fodder owing to scanty rainfall led to some of the reserves being thrown open.

The following remarks on the supply of grass to the local transport corps will be read with interest.

“ It may also be remarked that 41,408 maunds of grass were supplied to the local Transport Corps. This grass was partly brought in from Transport Birs and partly from Forest Reserves, and a certain portion was purchased at the Lines. The area of the Transport Birs being insufficient to meet the requirements of the corps, hence the anomaly of the Department purchasing grass.

This grass is not shown on the returns, as the accounts of this transaction are kept separate. The work of sending grass to Ajmere was in progress, the quantity was not entered on the books during the year, hence it is not shown in the Annual Returns. But it may be mentioned that about 8,000 maunds of grass had been sent to Ajmere, and a considerable quantity was ready for despatch at the Dosa and Mandawar Railway Stations.

The grass was pressed by Government Officers, who used both the Screw Press and Lever Hay Press. The latter was more useful, as the bundles contained about two maunds of grass each, and the pressing was neat and tidy, while by the screw press the quantity pressed was hardly one maund, twenty seers. The labour for bundling was about one anna a bundle, besides the cost of rope which was nearly three pies per bundle.

Each sort of press required three or four men to work. On the Rajputana-Malwa Railway some 105 maunds of grass could be carried in an open truck and about 60 maunds in a wagon.”

The total revenue appears to have been Rs. 29,388, and the expenditure Rs. 17,103 leaving a surplus of over Rs. 12,000. Both Colonel Jacob and Captain Tate speak in commendatory terms of the work done by the Superintendent of Forests, Bhai Sadhu Singh, and of the tact and energy he displayed.

Effect of the time of felling on the production and development of Coppice-shoots.

M. Bartet, Inspecteur Adjoint, in charge of experimental work in the forests at Nancy has published an interesting pamphlet “ On the influence of the period of felling on the production and development of coppice-shoots.” The experiments were very careful—quite like German work—and they are explained with that beautiful lucidity that only the French language can give. With the system, too, for which the French nation have such a “ penchant,” M. Bartet begins by citing the old rule guiding fellings for coppice in France, which has apparently been established without sufficient enquiry. This runs as follows :—

“ The coppice-shoots at first take a great part of their nourishment from the old root, and it is during the period of repose that the roots contain the greatest amount of alimentary reserve. On more we retard the birth of the shoots and the greater will be the number of the stumps that do not produce shoots till the second year.

' the other hand, if the felling is made before or during the
' winter, the cold may cause separation of the bark from the wood,
' a thing very prejudicial to the formation of shoots. The end of
' the winter, that is, in March, would therefore appear to be the
' best moment at which to exploit for coppice : the shoots are
' then well nourished and vigorous. Such is not the case with
' shoots produced after fellings made during the period of growth.
' Without considering the fact that this gives the shoots less time
' to grow, it frequently happens that the young shoots, still tender
' and poorly lignified, cannot stand the early autumn frosts.
' (Lorentz et Parade)."

The results of the experiments made during three years in the Forêt de Haye by M. Bartet do not bear out this rule altogether, although the actually best moment at which to fell does not differ very much from that at present adopted.

The oak, hornbeam and beech were experimented with on four areas cleared in the forest and divided up into 6 or 7 sections each of 9 ares extent (.2223 acre), each area being thus 1.3 or 1.56 acres as the case might be. The soil and position were such that M. Bartet is careful to explain that these experiments cannot be taken to have much more than a local value. The fellings were made in each month from March to September, a section in each area being dealt with in each month.

Part II is headed "Resultats constatés" and is divided up into:—

1. Date of appearance of the shoots.
2. Aptitude of the stumps to produce shoots.
3. Number of the shoots.
4. Nature of the shoots.
5. Height of the shoots.

and Part IV, gives the "Résumé and practical conclusions" which we will translate *in extenso*.

"These experiments were carried out on a very superficial soil and in an extreme climate, that is, under quite special conditions. Very probably, different results would be arrived at if the three species, oak, hornbeam and beech, were studied under conditions of a deep and damp soil and a climate gentler than that of Lorraine. Until more extended experiments have been made, we must not generalise from the conclusion here arrived at and they must in fact be limited to analogous situations. With this reservation we will now give the principal deductions to be drawn from what has been written above:—

1. "The coppice shoots appear at dates naturally very variable according to the period of the felling. Thus, when the felling is made in the middle of March or April, nearly all the stumps of oak and hornbeam which produce shoots at all will do so before the end of the year. On the other hand, if the felling is put off till the end of August it will be only in the following spring that the shoots of these two species will appear. The more we put off the date of the felling, starting from May, the

"The stumps of beech, whose shoots come chiefly from adventive* buds are slower in shooting than those of the two other species; and thus by exploiting the beech in the middle of August the stumps will be rendered incapable of producing shoots before the following spring.

2. "The period of felling appears to have but little effect on the proportion of stumps that remain completely inert and without shoots. However, we may suppose a felling in the middle of August to give, from this point of view, the least unfavourable results for the three species studied.

3. "The stumps rendered sterile by the death of all their shoots attain their maximum proportions with exploitations from May to July for the hornbeam and the oak.

4. "Everything considered, it is the hornbeam which is the least often sterile. The oak, in this connection, stands between the other two species.

5. "For the hornbeam, the number of stumps considered as really fertile differs very much, with the period of felling. For the oak there is only one time which seems completely unfavourable:—the middle of August. Finally, for the beech, it is the felling in May and June which seems the most advantageous from this point of view.

6. "The period of felling does not exercise a marked influence on the average number of the shoots per fertile stump with the oak and hornbeam. With the beech, on the contrary, the difference is very marked: it is the felling in June which is by far the most favourable for the production of shoots, while the forest shoots appear after fellings made in August and in March."

"The stumps of the beech, moreover, produce much fewer shoots than those of the oak and the hornbeam, generally nearly a half less."

"For the oak, the period of felling is also without effect on the nature of the shoots, these, except in rare cases, being always preventive shoots. On the contrary, for the hornbeam and beech but particularly for the latter, felling while in leaf augments the average number of adventive shoots per fertile stump and increases the proportion of stumps which bear only this kind of shoot.

"Adventive shoots are at their maximum number on stumps of hornbeam when the felling takes place in July, and on those of the beech when it occurs in June."

"Generally, stumps of beech produce a few more adventive than preventive shoots, while on those of hornbeam there are nearly eight times as many preventive as adventive shoots.

Adventive shoots come from buds produced by the cambium layer after the tree is felled and are generally placed on a "bourrelet" emerging between the bark and the wood at the level of the cut. Rarely also an adventive shoot will be produced from the cambium layer at a point where the bark has been rubbed off lower down. *Preventive* shoots come from normal buds on the parts of the stump above ground but which have remained latent.

8. "Considered at the close of the year following the felling, the height of the tallest shoots differs very much according to the period of the felling. For the three species in question the maximum in height corresponds to the felling in April and the minimum to that of the middle of August.

9. "If we take as a term of comparison the size of the shoots of two years produced by the felling in April, we may, without appreciable harm, wait to fell a coppice of oak till May, while to fell the hornbeam at this date would mean a loss of 20 per cent. For the oak the loss becomes marked if the felling is left till June.

10. "For the above two species, but particularly for the oak, fellings at the end of August and middle of September seem to give shoots much more vigorous and taller than in the case of individuals coming from a felling at the middle of August.

11. "The differences existing in the heights of the tallest shoots at the end of the second year, appear to increase in the third year, to the detriment of cuttings made during the season of leaf."

"Finally, if we bear in mind the divers aspects under which this question of coppice-shoots has been examined, we arrive at this double conclusion, viz, that

"For fellings in oak, hornbeam and beech coppice, the worst period is the middle of August.

"The best period is, on the contrary, the middle of April; but it is nearly equally good to fell in March and May in the case of the oak, and for the hornbeam March is nearly as good as April."

It will be noted that M. Bartet does not even consider the idea of coppicing in winter, and yet in N. India—where there is plenty of frost, that is generally the time adopted. I think I am right in saying that cutting flush in January, and February produces plenty of sal shoots. As also in early March (?) but I noted that this year in November the number of shoots from sal stumps (some inferior kinds seemed as prolific as usual) cut flush between the middle of March and the hot weather was almost *nil*: whether this was due to other causes or to the "epoque de l'abatage" I cannot say—and it may be that the late cutting, as in France, caused late shooting, but as I no longer hold that Division, I cannot speak to this and as a matter of fact one would think the heavy rainfall of the Kumaun Bhabar (where the forests were situated) would prevent this consideration (of late cutting) being of much consequence. If you coppice Shisham in March, there will be a thick mass of shoots 4 or 5 feet high in a month or two: root-suckers (*drageons*) appearing later, I think.

A. G. HOBART-HAMPDEN.

We have received, through the kindness of correspondents, two Reviews of this interesting work. As they differ in several respects from each other we purpose to print both, the other will consequently appear in our issue for October.

HON. ED.

Indian Meteorology

We have received Part 1 of Vol. V of those most valuable 'Meteorological Memoirs' whose publication is so creditable to the Indian Government and helps to place India in the foremost rank of countries which take an enlightened interest in science. This Part commences a most important review by Mr. H F. Blanford, F. R. S., the late Meteorological Reporter, who is evidently now devoting the well earned leisure of his retirement to the work, in which he proposes to discuss for each of twenty-five stations of importance throughout India, the diurnal variation of atmospheric conditions. The following is Mr. Blanford's preface to the work. The part now received discusses Sibsagar and Goalpara and the information it gives regarding these two stations, deserves to be consulted by Forest Officers in the Assam Province and especially by those who are employed in preparing Working Plans.

"In the year 1873, hourly observations of the barometer, thermometer, &c., in four days in each month were commenced at a few selected stations in Bengal and Assam with a view to ascertaining the normal diurnal variations of the temperature, pressure and other chief meteorological elements; partly as auxiliary to the regular daily observations and to furnish corrections for reducing the latter to true mean values, but chiefly as a contribution to physical meteorology, and to ascertain what differences might characterise the normal diurnal march of the atmospheric changes in different parts of the country. On the establishment of a Meteorological Department under the Government of India in 1875, steps were taken to extend this system to other parts of the empire, and eventually it was brought into operation at twenty-six stations, not including Calcutta, Bombay and Madras, at which such observations had already been recorded for many years, or which were provided with instruments for autographic registration.

At most stations in Bengal, Assam and the North-Western Provinces, the observations were continued until 1885; one only *viz.*, Goalpara, having ceased to furnish them in 1881, when the observatory was removed to Dhubri. Those of the Central Provinces, the Bombay Presidency, and Burma were discontinued in 1887 and 1888, and those of Southern India in 1889. At one station (Leh) they are still in progress.

We now possess hourly observations of temperature, pressure, humidity, cloud proportion, &c., recorded on the 7th, 14th, 21st and 28th days of each month for at least 10 years at sixteen observatories, and at a few for longer periods; at two for 9 years; and at two for between 8 and 9. At four stations in Bombay they have been recorded on three days in each month for 10 years, and at one station the series is not yet complete.

' Some small portions of these have already been published. The Allahabad observations of all elements for four years were discussed by Mr. Hill in a memoir published in the first volume of this serial in 1881; and the barometric series of Hazaribagh, for three years, and those of Goalpara, Patna and Leh for five, six and three years, respectively, were reduced and published in 1878 and 1881 in the same volume. These discussions must now be regarded as preliminary only; but they may be usefully compared with the results of the much longer series for the same stations that will be given in the present memoir.

' Each diurnal series of readings consists of 25 observations of the barometer, thermometer, hygrometer, wind direction, cloud proportion and rainfall, beginning and ending with midnight. Thus, the first and last readings of each series can be reduced to the same value, any difference being equally distributed through the 24 hours. The solar thermometer, a non-registering black bulb *in vacuo*, was observed only while the sun was above the horizon, and the ground radiation thermometer between sunset and sunrise. The wind vane was observed hourly, the anemometer hourly or only at intervals of three or four hours. All these will be discussed in the present memoir as far as examination of the registers shows that the data are trustworthy. In a climate in which the diurnal march of the several meteorological elements is so regular and strongly marked as in India, even from 30 to 50 series of horary observations for each month suffice to give a near approximation to the diurnal variations of temperature, pressure and humidity, and at least to indicate some of the characteristic features of the more variable elements, wind direction, cloud proportion and rainfall.

' The observations are made at the specified hours of mean local time, and except when otherwise mentioned, the reductions are all made to the same time standard.

' I propose to discuss the results of each station separately commencing with Sibsagar in Upper Assam; thence passing westward to Bengal, the Gangetic Plain, Central India, the Punjab and Sind, all lying without the tropics; and shall conclude with those of the Peninsular and Tropical Provinces, *viz.*, Bombay, the Central Provinces and Madras, and Burma in the Eastern Peninsula. The results of the whole will be compared and summed up in the final portion of the Memoir."

We may give as examples of the results the following mean annual temperature for the 24 hours at the two stations.

These shew that at both places 6 a. m. is the coldest, and 3 p. m. the hottest, time of the day. We should have liked to give also the pressure and humidity variation did space admit, but for all these our readers should consult the publication itself and especially the beautiful diagrams shewing the results by curves, the best of methods for giving clearly and easily the results of careful statistical observations.

	Midnight.	1 a. m.	2 "	3 "	4 "	5 "	6 "	7 "	8 "	9 "	10 "	11 "
Sibsagar ..	68.9	63.3	67.7	67.1	66.6	66.1	66.0	67.0	68.7	71.1	73.4	75.4
Goalpara ..	71.7	71.0	70.2	69.5	68.9	68.5	68.1	68.8	70.6	72.9	75.2	77.6

	Midday.	1 "	2 "	3 "	4 "	5 "	6 "	7 "	8 "	9 "	10 "	11 "
Sibsagar ..	77.3	78.8	79.8	80.3	79.7	78.2	76.0	74.1	72.7	71.6	70.6	69.7
Goalpara ..	79.3	80.4	80.8	80.8	80.3	78.9	77.3	76.0	75.1	74.3	73.4	72.6

Vegetable Cultivation in India.

We have received from the author a copy of a modest little handbook on the Vegetable Garden* by Mr. Gollan who is well qualified for such a work by his long and successful experience at Saharanpur. We can say for ourselves that we have already found the book very useful. It explains, for the North of India, the seasons when seeds should be sown and vegetables planted and it gives it all in a simple way which is a relief after the rather longwinded recommendations of some other books we have met with. And it explains some of the points not usually known, for instance that if you want to get good broad beans you must pinch the tops of the plants after they have flowered or the pods will not set. We have long been aware of this ourselves, but it did not occur to us that the complaints of our friends that they were not successful with beans were due to their possible neglect of this precaution. So too, how often we hear some people say that they cannot grow parsnips while others succeed admirably. Till we read Mr. Gollan's book we were unaware of the reason. He says:—

"The seed of the parsnip only retains its vitality for a limited period of time and seldom germinates in this country

*The Indian Vegetable Garden by W. Gollan, Superintendent, Government Botanical Gardens, Saharanpur. Indian Press, Allahabad, Rs. 1-8.

' unless it belongs to the crop harvested in Europe in August-September and sown in this country in October-November of the same year. Vegetable seeds which arrive in this country any time before the end of September and even for six weeks later, mostly belong to the crop harvested in Europe late in the summer or autumn of the previous year and although fresh from a seedsman's point of view, they are necessarily a year old when they reach his hands. In order to be sure of securing a crop of parsnips, special arrangements must be made to have the seed sent to this country immediately after it is harvested."

We think that some of the rarely cultivated vegetables like Aniseed, Caraway, Borage, etc, might have been omitted with advantage and some information given about fruit. We have ourselves looked in vain for information how best to grow strawberries.

At the end is a short chapter on flowering plants which we wish were more developed. These are minor failings and we can fully recommend this cheap little work to North Indian Forest Officers who are fond of gardening and are in want of a handy little manual to help them.

V.—SHIKAR.

Camp incidents in North India.

We were not aware, my wife and I, when we ordered our camp to move to the old fort amongst the bel trees, that we were marching to a lunatic asylum: we knew, of course, that there were no human lunatics about, because we were more than 100 miles from the station, and besides the casual cultivator and the wandering jungle tribes, there was no humanity within immediate hail. But we were, I regret, innocent of the fact that we had selected a camp amongst a community of intellectually deficient animals. We soon found it out however. It began with the calling of spotted deer at our door and of course we went out to see what was the matter, and equally, of course, we found the herd, and got our shot. But we returned without the stag, he left no blood trail and after a futile search we gave it up; next morning, however, we found his remains lying close to the road, and saw that a family of leopards had been feasting during the night. We speedily prepared a "machau" in case they should return in the evening, but they did not wait for darkness and when at 4 o'clock I strolled down to the "machan" they had already nearly finished the stag. I decided, however, to sit up

for an hour on the chance of more audacity, and was rewarded by getting a shot—and missing! Though it was nearly dark when I returned to camp, a sporting clerk of my retinue took my place in the “machan” and before 20 minutes had elapsed, the report of a gun followed by much talking was heard, and we learnt that the leopard had come back to the kill, had been mortally wounded, but had made off. Early next morning, we accordingly went out on the elephant to bring in the skin, but though we found blood plentifully at first, it soon ceased and tracking was impossible on the bare hard soil. Whilst engaged in the pursuit, however, a fine male leopard suddenly sprang from the grass on to a fallen tree not thirty yards off and calmly surveyed the scene; he was speedily felled by an express bullet.

I will pass over our meetings with tiger, sambhar and spotted deer during our morning rides; these creatures, although not avoiding us, showed no signs of dangerous insanity; but it was different with a mighty blue bull who took the road and declined to make room for our ponies. We called to our assistance a watcher armed with an enormous “lattie” but the bull merely shook his head when threatened and remained. Ultimately I had to ride back for a rifle and slay the “Nilgai” who in spite of mental aberration was in very good condition. We now began to feel somewhat shy at going about unarmed, but the inconvenience of carrying a rifle on horseback was too serious to overcome, and in consequence we were stopped next morning by a leopard who was only with difficulty persuaded to stand to one side whilst our ponies passed. In the afternoon this brute attacked some cattle on the road, and in the evening we went on a pad elephant to look for him. Hunting about in the forest for more than an hour, no trace could be discovered and we ultimately emerged on to the road to take the homeward way. There in the open lay our friend enjoying the cool of the evening and within 5 minutes he was a dead leopard. How we sighted his mate and lost her in the grass and duskiness of nightfall is of no importance in this narrative. Our time was now up in this sporting locality and we were obliged to leave the animals in possession of their asylum; we had made a good mixed bag which would have been doubled had we known the country well, if we had ridden armed, or if we had been aided by a decent “Shikari.” The man we had with us was worse than useless, he could neither shoot himself nor was he even the cause of shooting in others, and had it not been for the boldness of the animals, which gave us the “jumps” when unarmed and filled us with joy when carrying the trusty rifle, there would have been little worthy of note during our stay in these forests. As it was, we shall always remember with satisfaction our visit to a spot where the inhabitants feared not the gun nor regarded man.

VI.—EXTRACTS NOTES AND QUERIES.

Dew, and its action on Plants.

It is generally believed that dew exercises a great beneficial and refreshing influence on plants, and this supposition has provided poets with many beautiful comparisons. When a scientist however, declares that it is not a fact that dew is so important a means, and that its beneficial effects have been greatly overrated, it may be safely presumed that the scientist has good grounds for his assertion.

The reasons given by Professor G. Wollny of Munich, for combating the generally received opinion upon the formation and value of dew, are, as might be expected, weighty, and are based upon the researches of several years. These researches prove that dew is not, as is generally supposed, formed by condensation taking place in the atmosphere immediately over the plant, and according to which theory the dew falls on the plants; but that the dew-drops are caused principally by the moisture arising from the earth—a theory first proposed by Gersten in 1833.

It will be seen that the co-working of the earth-moisture is necessary for the formation of dew, and it will be easily understood that this has a great effect upon the question as to the value of dew as a refresher of plants.

That the generally-accepted theory of the formation of dew is incorrect, is proved conclusively by Wollny, who states that in the field where he made observations the dew was sometimes much heavier in one place than in another; and that while the difference could not be accounted for by the supposition that there was so much difference in the moisture of the atmosphere immediately over the places in question, the difference of moisture in different parts of the field accounted easily for heavy or light deposition of dew. Wollny's researches prove conclusively that quantity of dew deposited depends upon the moisture of the earth.

A certain amount of moisture is attracted by the roots, and sent up into that part of the plant which is out of the soil. The quantity of moisture thus abstracted by the plant depends not only upon the moisture of the soil at that particular spot but also on the temperature. The higher the earth-temperature the greater is the amount of moisture abstracted by the plant.

In winter, when the temperature of the ground is so reduced, the plants can extract little or no moisture, but at the same time they continue to give out from their upper portions to the air. It is because of this that they often die; not because they are frozen, but because they are parched to death. In summer nights, however, the earth cools very slowly, and loses very little of its heat, and, from this reason, the plants abstract a great quantity of moisture; so much, in fact, that the water sometimes oozes from the leaves; or, in case the surface of the leaves is suddenly cooled, is condensed, and given off in drops.

Wollny concludes, therefore, that the presence of dew on plants is owing to the action of the moisture drawn up by means of the roots into the upper part of the plants, combined with the action of the moisture rising directly from the earth itself.

It may be remarked here that the leaves of certain plants are so formed as to permit secretion and accumulation in case the evaporation is weaker than the power of suction, or rather when more moisture is absorbed from the earth than is given off into the air. When a hot day is followed by a cold night, the edges of the leaves of (such, for instance, as the *Alchemilla vulgaris*) are found covered by big drops, which cannot be considered as dewdrops, whichever theory of dew formation be accepted. The great use of dew as a means of supplying plants with moisture is, therefore, as shown by Wollny, an error, for the plants can only be adequately refreshed by earth moisture absorbed by the roots.

Dew was said to refresh the thirsty plant. The plant thirsts if it does not receive a sufficient amount of moisture from the ground to supply that which is abstracted from them by the atmosphere. In times of drought, when the earth is more or less parched, and moisture is of the greatest necessity for plant life, there is no dew; besides which the amount of moisture which a plant can absorb by means of its leaves (save only in exceptional cases) is very trifling.

If the leaves and buds, which during the heat of the day are parched, regain their freshness during the night, it is not owing to the refreshing influences of dew, but simply because the air having ceased to extract so much moisture from the plant, and the suction from the earth always continuing, a fresh supply of moisture has been laid up. The dew is only of use in providing the leaves of plants, as it were, with a covering which is some defence against the continual suction of the atmosphere; but even this is not necessary, for the parched parts of the plant can become fresh without a dewy covering. After all, concludes Wollny, there is no doubt that the value of the work of dew has greatly over-estimated, and has not been in accordance with facts.—(*J. Matthewman, Worsbro' Dale, Barnsley, in the Gardener's Chronicle.*)

Forest destruction and Russian Famine.

At first sight there would not seem to be much connection between these two subjects; however, we extract and lay before our readers the following letter from the "Spectator" which we think will interest our readers.

SIR,—You ask in the *Spectator* of June 11th, referring to the official opinion in Germany that the famine in Russia has not been due to an accidental drought but is the outcome of a steady decay of agricultural prosperity: "What change is it that they think has occurred in the rural districts of Russia?"

The following paragraph, taken from a much-read German Agricultural Gazette, may interest you, since it mentions the cause to which this decay is attributed:—

"The wanton despoiling of Russian forests during these last thirty years has led to such widespread devastation in the woodlands, that industrial Western Europe in at present richer in woods than Central Russia. The havoc wrought in the forests has had the result that the abundance of water in rivers and inland lakes has decreased; that immense masses of quicksand have been formed, which encroach steadily upon the cultivated land that the Russian territory is becoming desiccated and nature impoverished; that the temperature in summer has increased by three degrees, and decreased in winter to the same amount. Professor Bogdanow, who has diligently studied these subjects for years, predicts, upon the above grounds, that the metamorphosis of the 'black earth' into a desert will be accomplished within the next century, unless this destruction of woods be proceeded against with ruthless energy."

—I am, Sir, &c.,

A GERMAN READER OF THE "SPECTATOR."

Seeds of the Sugar Maple.

A correspondent wishes to try the cultivation of the Sugar Maple (*Acer saccharinum*) of North America in the N.-W. Himalaya, can any of our subscribers tell him where he can procure seed; the name of some American or Canadian seed firm would probably be enough.

Match Manufacture in India.

We have had an opportunity of examining the woods which the Indian Match Factory, Limited, intend employing for their match-boxes and match-sticks, and, as far as we can judge, they seem admirably adapted for the purposes. That which it is proposed to use for the boxes is distinctly superior to the woods generally employed for the same purpose elsewhere. It is tough, close-grained, and extremely flexible, and—though this is of no importance in connexion with match-boxes—it possesses a silky-texture and a grain which, when polished, would probably be pleasing to the eye. The wood for the match-sticks, while quite strong enough for the purpose, ignites somewhat more freely and burns more steadily than that of ordinary English or Swedish matches. Both woods are, we understand, obtainable in the Sunderbuns in abundance. Under these circumstances, we see no reason why the company, which, in addition to cheap wood, will have the further advantage of cheap labour, should not make a very handsome profit, and distance all competitors. A large portion of the shares, we hear, have already been taken up, and the necessary machinery has been ordered.—*Indian Agriculturist*.

The largest Band-saw Machine ever made.

Messrs Ransome of Chelsea, the well-known makers of wood-working machines, have just constructed the largest band-saw machine which has ever been made. The saw itself is an endless ribbon fifty-four feet in length, and eight inches wide, which travels at the rate of seven thousand feet per second over wheels or pulleys, which are no less than eight feet in diameter. The entire height of the machine is twenty feet, and it weighs as many tons. The saw has been made for a company in New Zealand, where the timber—mainly blue-gum trees—grows to an enormous size, and can only be dealt with by exceptional appliances.—*Chambers Journal*.

State forestry in America.

A Bill has been passed by the Legislature of New York to establish a great forest reserve or State Park among the famous Adirondack Mountains. In signing the Bill, the Governor says:—"Out of 3,700,000 acres of land comprised in this region, the State now owns about 900,000 acres, half of which is situated, in detached pieces, around the border of the wilderness. The intention of the Act is to enable the State to sell as much of this outside holding as may seem wise, and to buy in place of the lands thus sold more desirable timber lands near the great streams which have their source in the Adirondacks, so that the end sought to be attained by the establishment of an Adirondack park may be more certainly accomplished. The advantage of this legislation is twofold. In the first place, it is estimated that the State will be able to increase the acreage which it holds; secondly, the carrying out of the project contained in the Bill will consolidate the State's holdings and enable the State to pursue some rational and practical system of forestry, which is virtually impossible now. The scheme proposed by the Bill carries no appropriation with it, but all revenues from the sale of the so-called 'outside' lands will be devoted to the purchase of new lands better adapted for the purposes of a forest preserve. I have cheerfully approved the measure, for I believe thoroughly in the wisdom and actual necessity of preserving this great timbered wilderness for the protection of the headwaters of our streams, the commerce of the State, and for the benefit to agricultural interests which it yields in its important influence upon our rainfall."—*Times.*

White Wax in China.

The native candles of the north are made of sheep's tallow, but those of the Central Provinces are partly manufactured from bean oil, which is able to be utilised for this purpose by the addition of white insect wax in the proportion of about one-eighth. Where bean oil cannot easily be procured, the seeds of *Stillingia sebifera* are employed. This tree grows most extensively in the south. A picul of its seeds yields twenty or thirty catties of tallow, and when this has been pressed out, subsequent grinding and steaming result in the production of an oil called *ch'ing yu* out of the albumen. Insect made white wax is added in the proportion of three catties to a hundred catties of the tallow. It is the wax which gives it sufficient consistency to remain thoroughly congealed in ordinary temperatures. From Hankow in 1889-

about 120,000 piculs of the tallow of the tallow tree were exported, and of the quantity nearly half found its way to Shanghai in the same year. An enormous quantity of candles are made in Shanghai and its vicinity, and the pressing out of bean oil for the manufacture employs a large number of water buffaloes. The old industry is that which has for many ages made use of the tallow tree product. The new has grown out of the Newchwang trade, which supplies Shanghai with beans. The vast industry, which is an essential to the use of the vegetable tallow began, we are told, about six centuries ago. Till recently we knew generally that wax is made at Luchou Fu, in Anhui, at Kiahing in Chêkiang, at Hinghua Fu in Fukien, as well as in Hunan, in Kweichou, in Yunnan and Szechuan. But the processes were never fully described, and there was a need for fuller information. That want has been recently supplied by the inquiries of Mr Alexander Hosie of the British Consular service in Szechuan. The tree on which the insects produce the wax is an inhabitant of a different part of the country from that which produces the insects. Chinese ingenuity brings the insects from their birthplace to their new home many miles away and sets them to the work of wax-making. It is this curious history which Mr. Hosie has been the first thoroughly to investigate.

The white wax insect was frequently referred to in old works on China. One object of Mr. Hosie's recent journey to the Chienchang valley near Mount Omi was to procure from the tree on which the insect lives specimens of the foliage and flowers, for Sir Joseph Hooker. These he procured and specimens of the living tree with the incrustated white wax on it, as well as samples of the latter as it appeared in commerce and of the Chinese candles, made from it. The said valley is 5,000 feet above the level of the sea, and is the great breeding ground of the insect. The tree is an evergreen with the leaves springing in pairs from the branches, very thick, dark green, glossy, ovate and pointed. In May and June it bears clusters of white flowers, succeeded by fruit of a dark purple colour. The Kew authorities now say it is the *Ligustrum lucidum*, or large-leaved privet. In March Mr. Hosie saw on the tree certain brown penshaped excrescences attached to the bark of the boughs and twigs. Opening some larger ones they presented either a whitey brown pulpy mass, or a crowd of minute insects looking like flour. Their movements were just perceptible to the naked eye. From two to three months later they become brown creatures with six legs and a pair of antennæ. These are the white wax insect or *Coccus pela*. There is a beetle which lives on the *Boccus*. It is a species of *Brachytarsus*. It is found in many of the excrescences above mentioned and burrows in the inner lining of the scale, which seems to be its food. When a scale is plucked from the tree, *Cocci* escape by the hole which is made. It is in the town of Kiating that

insect white wax is produced. This city is 200 miles to the north-east of the Chienchang valley. The scales are gathered in the valley and made up into paper packets of about sixteen ounces each. Sixty of such packets make a load, and they are conveyed by porters from the valley to Kiating in the night time. If carried by day the insects would develop and escape from the scales. As it is, an ounce is lost in transit. A pound of scales in good years is sold for half a crown. In bad years it is worth twice this amount. In favourable years a pound of scales produces four or five pounds of wax. In the plain round Kiating very many plots of ground are seen edged with stumps from three or four to twelve feet high, with numerous sprouts growing from their gnarled heads, as on pollard willows in our own country. The tree is probably *Fraxinus chinensis*, a kind of ash. The leaves spring in pairs from the branches and are light green, ovate, pointed, serrate and deciduous. On the arrival of the scales in May they are made up in small packets of from twenty to thirty scales, which are enclosed in a leaf of the wood oil tree. Rice straw is used to suspend the packet under the branches of the ash or wax tree. Rough holes are drilled in the leaf with a blunt needle, so that the insects may find their way to the branches through the openings. The insects creep rapidly up to the leaves where they nestle for thirteen days. They then descend to the branches and twigs and take up a position on them. The females then begin to develop scales on which to deposit their eggs, and the males to excrete the substance known as white wax. It first appears as an undercoating on the side of the boughs and twigs, looking like snow. It spreads gradually till in three months it is a quarter of an inch thick. In a hundred days the deposit is complete and the branches are lopped off. The wax is removed chiefly by hand and is placed in an iron pot of boiling water. The wax on rising to the surface is skimmed off, and deposited in a round mould. This is the white wax of commerce. It is used to coat the exterior of animal and vegetable tallow caudles and to give greater consistency to the tallow. It is also used to size paper and cotton goods, to impart a gloss to silk and as a furniture polish. From Hankow each year at present about 15,000 piculs of white insect wax are exported in a year, and the main portion of it finds its way to that port from Szechuan. Chinkiang absorbs 1,000 piculs, and Shanghai 14,000 piculs. At Shanghai one-half is for home use and the other half to distribute again to other ports. Tientsin requires 1,000 piculs, and Canton and Swatow a thousand piculs each. Thus it appears that while Szechuan is not the only producing centre of insect white wax it produces enough to furnish the most distant cities with the means to make a sufficient number of candles to maintain the temple worship as well as to enable the people everywhere to equip their lanterns for walking in the evening, and aid in night illumination generally—*N. C. Herald*.—(*Indian Agriculturist*, June 11th, 1891.)

VII.—TIMBER AND PRODUCE TRADE.

Churchill and Sim's Circular

August 5th, 1892.

EAST INDIA TEAK.—The market remains lifeless, the consumption continuing to fall away, though the great reduction in the quantities arriving maintains quotations fully at the level reached in June. For planks and for any special lengths or sizes of Timber for which demand arises, prices can be at once advanced. The deliveries for July amount to only 756 loads, comparing with 918 loads and 1,732 loads in July, 1891 and 1890 respectively, making the totals for the seven months 6,421 loads this year, as against 8,973 loads in 1891, and 9,085 loads in 1890.

Price Current.

Teak	per load	£9 10.	to	£15.
Cedar, Malabar,	per sup. ft.	3d.	to	3½d.
Satinwood	per ton	£6.	to	£10.
Rosewood	"	£7.	to	£11.
Ebony	"	£7.	to	£10.

VOL. XVIII]

[No. 10.

THE
INDIAN FORESTER ;
A MONTHLY MAGAZINE
OF
FORESTRY,
AGRICULTURE, SHIKAR & TRAVEL.

EDITED BY

J. S. GAMBLE, M.A., F. L. S.,

CONSERVATOR OF FORESTS, AND DIRECTOR OF THE
FOREST SCHOOL, DEHRA DUN.

OCTOBER, 1892.

MUSSOORIE :

PRINTED BY THE MAFASILITE PRINTING WORKS
COMPANY, " LIMITED."

1892.

Contents.

No. 10—OCTOBER, 1892.

	Page.
I.—ORIGINAL ARTICLES AND TRANSLATIONS.—	
<i>Forest Administration in the Central Provinces, by 'Tuscan.'</i>	373
<i>Durability of Railway Sleepers, by A. S.</i>	379
<i>Forest and Revenue Officers</i>	379
<i>On Pruning—translation from the 'Revue des Eaux et Forêts, by A. F. G.</i>	383
II.—CORRESPONDENCE.—	
<i>Teak in Travancore, letter from "A. F. B."</i>	385
<i>Improvement in the Indian Raspberry by cultivation, letter from W. Gollan</i>	386
<i>Note on the reproduction of Shisham, from 'T'</i>	387
<i>Fires caused by bamboo friction, from S. E.-W.</i>	388
III.—OFFICIAL PAPERS AND INTELLIGENCE.	
<i>Good conduct badges</i>	389
<i>Budget Estimates of the Forest Department for 1892-93.</i>	390
IV.—REVIEWS.	
<i>The influence exercised by the season of felling on the production and development of coppice shoots, (Second Review of recent work by E. Bartet)</i>	391
<i>Annual progress Report of State Forest Administration in New South Wales for 1890.</i>	395
<i>Peach culture in Simla District</i>	401
V.—SHIKAR.—	
<i>Hollow-fronted Bullets and large game, by 'O. C.'</i>	402
VI.—EXTRACTS, NOTES AND QUERIES.—	
<i>The Coopers Hill Prize day</i>	404
<i>A serious grievance</i>	405
<i>Wattle bark for tanning</i>	405
<i>A Tea-Estate pest in the Dún</i>	406
<i>A corner in "Nuns."</i>	407
<i>State Forestry in America</i>	407
<i>The Brandis Prize</i>	408
VII.—TIMBER AND PRODUCE TRADE.—	
<i>Churchill and Sim's Circular, September 5th, 1892.</i>	408
<i>Market rates for Products</i>	409
VIII.—EXTRACTS FROM OFFICIAL GAZETTES.—	

SUPPLEMENT.

Appendix series of the Indian Forester.
"Ltc."

THE
INDIAN FORESTER.

ERRATA.

JULY No. 1892.

- Page 258, line 19, *for* 'except to proven' *read* 'except to approved'
Page 262, last line but three, *for* 'advertising it' *read* 'advertising ordinary trade turpentine'
Do. ,, last line but one, *for* 'new' *read* 'now.'

AUGUST No.

- Page 298, line 25, *for* 'Hotgat' *read* 'Hatgat'
" " 33, *for* 'Atlur' *read* 'Attor'
" " 35, *for* 'India' *read* 'Nidta'
" " 40, *for* 'Kirajpet' *read* 'Virajpet'
Page 302 " 24, *before* 'in appearance'
add " Now we come to the Naudi, and though there seems to be an undefined idea that"
line 28, *for* 'Mattis' *read* 'Naudis'
Page 323, line 19, *for* HERZEGOVIAN' *read* 'HERZEGOVINA'
" 327, last line but one, *for* 'radish' *read* 'reddish'
last line *for* 'Sissue' *read* 'Sissu,' and before it *insert* 'or.'

lined by the name of the Circle, being situated either in the North or in the South.

Turning to the Annual Report for 1890-91 we find that the Northern Circle is in possession of 10,100 square miles of

Contents.

No. 10—OCTOBER, 1892.

Page.

I.—ORIGINAL ARTICLES AND TRANSLATIONS.—

<i>Forest Administration in the Central Provinces,</i> <i>by 'Tuscan.'</i>	373
<i>Durability of Railway Sleepers, by A. S.</i>	379
<i>Forest and Revenue Officers</i>	379
<i>On Pruning—translation from the 'Revue des</i> <i>Eaux et Forêts, by A. F. G.</i>	383

II.—CORRESPONDENCE.—

Market rates for Products 409

VIII.—EXTRACTS FROM OFFICIAL GAZETTES.—

SUPPLEMENT.

Appendix series of the Indian Forester.
"Lac."

THE
INDIAN FORESTER.

Vol. XVIII.] October, 1892. [No 10.

Forest Administration in the Central Provinces.

The future administration of the Government Forests of the Central Provinces has had and continues to demand the greatest consideration of the Local Government. There are sure signs that the very necessary task which has been imposed upon the authorities will soon be brought to a completion, and some result will be arrived at ; but how far this is likely to be consistent with the maintenance and welfare of the forests and their improvement in firm forest principles is a matter of the greatest doubt and appears to be causing a certain degree of trepidation among Central Provinces Foresters. The present moment would, on these very grounds, appear a timely one to discuss the present administration and management of the Government Forests ; and to make a few remarks with reference to the lines along which impending legislation is likely to follow, as far as can be judged by the official writings, in the form of suggestions, which have from time to time appeared.

I. The present forest administration.

The Central Provinces, for purposes of forest management, are divided into two Circles, or Conservator's charges. Both the Northern and the Southern Circles—for such are their names—are divided into eight Forest Divisions each of which is in charge of a (so-called) Divisional Forest Officer. These divisions, with only one real exception, in which case the forests of two districts form part of one forest division, correspond as nearly as possible with the Civil Districts into seventeen of which the Province is divided ; and their geographical position in the Province is defined by the name of the Circle, being situated either in the North or in the South.

Turning to the Annual Report for 1890-91 we find that the Northern Circle is in possession of 10,100 square miles of

Government Forests, compared with 9,972 square miles in the Southern Circle : so that if merely an average be taken it will be seen that each division of the Northern Circle occupies an average area of 1,262 square miles, compared with 1,246 square miles for each division of the Southern Circle. And, though these numbers are in themselves enormous it should here be noted that particular divisions are in possession of far larger tracts than appears from the average. Among these, the Chanda Forest Division alone may be mentioned, the forests of which, scattered throughout the district, occupy a total area of 3,463 square miles. This question of the enormous area which falls to the charge of one executive officer need not be entered into here.

The Government Forests which form part of a division, may be divided into two classes, and for this purpose two classifications suggest themselves. The one we will call the "official" classification; the other the "working" classification—each of which it will now be necessary to consider. The following is the classification of the Reserved Forests adopted by the Local Government, which we have termed the "Official" classification:—

- A. Class Forests. Reserves under strict conservancy or to which it has been decided to extend strict conservancy as soon as possible. ... 9,093 Sq. Miles.
- B. Class. Other Reserves, classed as:—
 - B. (1) Areas selected from time to time as available for the introduction or extension of cultivation ... 484 Sq. Miles.
 - B. (2) Other areas ... 10,164 "

It is not necessary here to enter into the question of "unclassed State Forests and Waste Lands." The area of these is comparatively small, occupying some 393 square miles: and "steps will probably be taken before long to have the 'greater portion of it declared to be Reserved Forests.'"

As regards the above classification it may be said without any great fear of contradiction that it chiefly exists on paper—that it is chiefly an official classification. As a matter of fact both A. and B. Class Forests are merely one and the same. It is true that generally many of the A. Class Forests are in a somewhat better condition, and are, in a way, more strictly watched: whilst, on the other hand, the idea is more or less prevalent that the B. Class Forests are to be loosely governed. This however, is merely a matter which varies with districts; and, especially, as regards a *particular* A. Class Forest and a *particular* B. Class Forest. It is, however, correct to say that no real distinction does occur or need exist between the A. Class Forests and the B. Class Forests. Whatever difference, if any really occurs, will be made apparent in the classification, which we have termed the "Working" Classification, and which will now be explained.

It should be stated at once that this classification is not one that has been recognised as a classification. It is, however, here introduced as an easy way of describing the actual working of the forests: and as one which actually exists in practice. It is as follows:—

		Square Miles.
Open Forests = 18,029
Closed Forests = 2,044
	Total	... = 20,073

I. The Open Forests are Reserves, whether of A. or B. Class, which are open to the extraction of forest produce by any purchaser of forest licenses.

II. The Closed Forests are those which are closed to the extraction of forest produce. In this class, as a general rule, merely A. Class forests are included, but B. Class forests also do, as a matter of fact, occur.

Take the Closed Forests. It should first be noted that sub-classes might be made in which areas though *closed*, are opened to the extraction of one particular kind of produce: or in which certain workings, principally with teak as the subject, are at intervals carried out. For the purpose of this description, the above classification is sufficient and sufficiently correct. Neither is it necessary to say anything here with reference to certain areas which are closed to "grazing," for these belong to Class I or Closed Forests.

To dispose of the Closed Forests, for the present, it need only be said that their appellation describes their working. It must not be imagined that over-worked, or exhausted forests are—save as a rule, placed in this class: on the contrary, it is the best forests, teak-bearing tracts; in a word those which were, or promised to become, well stocked areas have been placed in this class. In a few of the more advanced districts, a certain amount of revenue is realized from these closed areas by the sale of teak trees; in others the areas are totally closed; whilst again in others a small revenue is sometimes made by selling gnarled, hollow, and crooked teak trees. The above operations, whatever be their nature, with but two exceptions, are invariably designated as "improvement fellings." This fact is only referred to as giving in itself a reliable idea as to their working: and to the manner in which the closure is applied.

In defining Class I. termed Open Forests, it has been said that these are the Reserves, whether A. or B. which are open to the extraction of forest produce to all or any purchasers of forest licenses. This leads one to consider roughly the manner in which these forests are worked: or,—as this expression leaves the erroneous impression that something is actually done, we should

say—the manner in which the revenue is realized, for in reality nothing more than this is implied.

For this purpose so-called License Vendors are scattered about a district and are obliged to sell forest licenses, (*viz.*, vernacular forms after the fashion of Form No. 13, Indian Forest Code; on which the necessary entries are made, forest stamps to the value of the produce described are affixed by the License Vendor, himself) for any of the Open Forests to any purchaser for any quantity of produce, or any kind of produce that the purchaser is ready to pay for in cash—with certain exceptions. These exceptions which only slightly modify the general rule, are best described by saying that in most districts the various species of forest trees are divided into a certain number of classes varying from 2 to 6, to a few of which certain restrictions are made. These classes vary considerably in most districts: but the following may be taken as a good sample of the more complete lists:—

Class I.—*Tectona grandis*; *Shorea robusta*; *Pterocarpus Marsupium*; *Dalbergia latifolia*; *Hardwickia binata*; *Terminalia Arjuna*; *Bassia latifolia*; *Mangifera indica*; *Melia indica*; *Terminalia Chebula*.

Here follow various classes according to the rates at which licenses for that particular species of that class are sold. *Class Z.* *Sterculia urens*; *Cochlospermum Gossypium*; *Dalbergia paniculata*; *Bombax Malabaricum*, *Garuga, pinnata*; *Boswellia thurifera*, *Butea frondosa*; *Odina Wodier*; *Erythrina indica*; *Kydia calycina*. As a rule, trees of *Class I* cannot be cut without the special sanction of the Conservators.

Class I to *Class Z.* are merely formed with a view of grouping together species for which the rates are the same. There is no restriction to the sale of forest licenses for these species.

In many districts the species of *class Z.*, when green, are actually permitted to be cut as firewood. Other restrictions are, also, sometimes made, especially with reference to the circumstances of trade: but how far these restrictions are, for any practical purposes, adhered to, must be left to be conjectured.

It is enough to lay stress upon the fact that any purchaser once in possession of a license has the run of a whole forest for the purpose of satisfying his desires, within the limits of the extent to which he has paid for them as defined by the license he holds. This, in fact, and in practice, constitutes the so-called working of the open forests. That the system is as pernicious as it is unscientific need not be entered into here. It is enough to say that the fact is thoroughly recognised by all Foresters and as a Conservator has already described it: "No forests into which a purchaser can go armed with an axe and a license to fell trees and bamboos at his will can ever be said to be properly worked by us. The license system, however carefully worked out

‘in detail, is vicious in principle.’ Before concluding these remarks on the present administration of the Government Forests of the Central Provinces, it may be well to add that it would appear after a careful inquiry into the matter, that up to the present no “Forest” Department—taking the strict and literal meaning of the word—exists in these Provinces. The forests are merely looked upon as a means of collecting revenue from the people; and, bearing this in mind, the Department cannot be strictly termed anything far beyond a “Forest Revenue Collecting Department,” the word forest being merely a qualificative adjective, qualifying the part it plays in the Revenue Collecting system of these Provinces. It will not be denied here that serious protest may be received from one or another Divisional Officer to the effect that in such and such a district, for example, plans have been prepared for a forest covering an area of over two square miles, so that annual cuttings in alternate lines 3 feet broad may be carried out or, in the same manner, stress may be laid on other equally amateur performances. We have no desire to detract from these jewels in the ocean. But the fact remains that no Working Plans exist in these Provinces, and what is worse, no Annual plan of operation has ever been drawn up with a view to working a certain forest for a series of consecutive years: such a plan forming in itself, as it were, a rough working plan. The fact is, the more the present forest administration of the Central Provinces *as a whole* is considered, the more one is compelled to arrive at the conclusion that the Central Provinces forest officer is, as regards his duties, nothing more than a tahsili peon. How far the officers are reduced to this condition by the administration will, we hope, be made fully apparent.

II. *Impending legislation.*

When the management of the Government Forests at the present moment is borne in mind; and the total want of science and of even the mere principles of forestry—a fact we have attempted to explain—is acknowledged, it may be thought that any change would have been hailed with pleasure by all true foresters in that it could only have afforded a means of betterment. How far these expectations have been dashed to the ground will be made apparent. It may be said at once that, as far as can be judged by the news already made public by the Local Government, the last stage threatens to be worse than the first. And to make this clear it is only necessary to roughly consider the proposals which have been made. It appears that in the summer of 1891, a forest conference was held at Pachmarhi and one of the decisions arrived at was that the present license system, which has been explained above, by which the purchaser has to obtain a separate license for every article of produce required by him at any one time, from the forest, caused unnecessary harassment to the agriculturists of these Provinces. And further that the rates

in force for articles required by Agriculturists for their own use were unnecessarily high. It has been found necessary, therefore to remedy these evils. The methods which threaten to be employed, however, cause much distress to all *forest* officers. It is suggested, in a word, to introduce "commutation." By this is meant that a man by paying a small fixed sum annually obtains a forest license which holds good for one year, and covers, during the whole of that period, the grazing of the cattle required for husbandry; and the taking, for his own use, of unlimited supplies of firewood, grass, leaves and fencing; and limited quantities of wood for agricultural implements. The possessor of such a license is naturally to be permitted to enter any of the open forests at his will and pleasure and to remove from any part of the same as much produce as he requires, according to his own estimate. This system is an old one in these Provinces and one which has been practically eradicated during the course of many years with the greatest difficulty. It is heartrending to think that this system is to be re-introduced, and all thoughts of any advance towards the introduction of principles of forestry to be abandoned, at least for the present. The writer is aware that certain restrictions to a general commutation are contemplated, chiefly in the direction of allowing these privileges only to certain classes: but this in no way alters the general principle of the case. Further, it will be acknowledged that, even allowing the above privileges, scientific, or at least *reasonable*, working of the forests, might be introduced *pari passu*. No such steps are, however, contemplated: and once the commutation system has been re-introduced and acknowledged as a system, the difficulties of afterwards introducing into them any attempts at scientific working will be insurmountable. The fact is, whatever may be said to the contrary, with the introduction of commutation, whole forests will be thrown open to be exploited at the will and pleasure of certain privileged classes throughout their whole length and breadth, irrespective of the area, the growing stock, or the annual increment.

It is not difficult to conceive that a rational system on forestry principles could be introduced by which (a) cheap wood for agricultural purposes; (b) cheap grazing; and (c) the welfare of the people, could be obtained. It would appear that if the Department is to justify its existence as a "*Forest Department*" and a technical department, its time has come. Once the objects to be attained have been clearly defined and laid down, the Department should be able to draw up plans on forest principles to attain these ends. Only one condition would appear necessary. The present net revenue collected by the C. P. forest department agency is about four lacs. This sum must not be insisted upon during the first few years of the introduction of forestry and a Forest Department.

TUSCAN.

Durability of Railway Sleepers.

In our August number last year we noticed the annual statement published by the Public Works Department shewing the renewals of wooden sleepers on State Railways; and we are now enabled to carry our review up to the end of 1890.

On the Ajmere-Khandwa Section of the Rajputana-Malwa Railway—there has been no change as regards Deodar sleepers; out of 2,054 laid down in 1876, 93·6 per cent. were still sound at the end of 14 years. Out of 689 teak sleepers, 67·5 per cent. were still sound, but creosoted pine had lost 4,158 out of 6,585, or over 63 per cent. within the same time.

On another section of the same line, however, deodar has not done so well, but the number laid—450—was almost too small to experiment with.

The figures given on pages 10 and 11 of this statement are somewhat misleading unless carefully looked into; the results on this railway are thus summed up:—Average age of sleepers removed;—deodar, 9 years; teak, 13 years; anjan, 12 years; creosoted pine, 8 years; and so on. This may be perfectly true, but it does not mean that teak lasts longer than deodar. The question is, after the lapse of a certain number of years, how many of the original sleepers laid down are still good? The answer is distinctly in favour of deodar.

We cannot quote any figures for another railway in a dry climate which seems to suit deodar—the North Western.—as this line is conspicuous by its absence from the present return. We see in a foot-note that the figures for this railway are under revision by the authorities and that the return for 1891 will give complete information.

The Eastern-Bengal railway shows the merits of Sal as a sleeper: on the main line, 1,973 Sal were laid down in 1877 and 63 per cent. were still in use as the end of 13 years. On the Rungpore branch of the same railway, 2,006 Sal sleepers were laid down in 1879, and 18 per cent. remained sound at the end of 1890. The conclusion, so far, is that no indigenous timber can compete with deodar.

Forest and Revenue Officers.

We have received three numbers of the '*Times of India*' in which are letters on this subject from 'Velleda' and in one a reply to him by 'C. S.' We are sorry we cannot sympathize with the style of 'Velleda's' writing: it seems to us more calculated to intensify than to reduce the departmental jealousy of which he talks so much; consequently, we do not reproduce his letters.

At the same time, it would certainly seem that Bombay Forest officers have considerable cause for complaint, especially if we are right in understanding it to be the case that the Collectors issue Forest orders independently to Mamlatdars without consulting their District Forest Officers. We believe that most competent persons who have studied the subject, have come to the conclusion that it is absolutely necessary for some connection to be established between the Revenue Department and the Forest Department; and that, consequently, almost everywhere, such a connection has been established. The way in which it is done differs in different Provinces and even in different Revenue Divisions and Districts. In the N.-W. P. and Oudh, all correspondence between the Conservator and Government on important subjects and especially those relating to land, has to be sent through the Commissioner; and (though to a great extent the Rule is not always fully observed in practice) the correspondence between Conservators and Divisional Officers upon certain scheduled subjects has to go through the Collector. In Lower Bengal and Assam, it is, we believe, much the same, and the procedure in the Central Provinces does not greatly differ. In the Punjab they go a step further and on most subjects we believe the Conservator has to address the Financial Commissioner, while the Divisional Forest Officers are District Forest Officers whose correspondence has to pass through the Deputy Commissioners of Districts. But all these are more or a less half measures and do not succeed in doing what their originator (we believe Sir D. Brandis) intended, and that is—enlist the sympathies of the Revenue authorities with the Forest work. When he drew up his proposals for the reorganization of the Madras Forest Department in 1882, Sir D. Brandis arranged that the Conservators should be under the Board of Revenue, at any rate until the selection and demarcation and settlement of the Reserved Forests was complete, and the good policy of this was clear enough. So, too, the Divisional Forest Officers were made Assistants to the Collectors of Districts and not merely so in a half-and-half sort of way, but fully, the Collector being the person responsible for the management of the forests under the recommendations made by the Conservator, and the District Forest Officer being his Assistant charged with the executive work. The District Forest Officer had his office in the District Cutchery; he issued his orders to subordinates on the one hand or wrote to the Conservator on the other, in the Collector's name; and he consequently, wherever he went, reflected some of the Collector's power and authority. But there the matter stopped: no interference was allowed to Sub-Divisional and Taluq Revenue officers, and if orders were issued to them, they were from the Collector's Forest Branch and signed (after drafts had been passed by the Collector) by the 'District Forest Officer for Collector.' We understand that latterly some modifications have been made in

this system, and if it is the case, we are sorry ; for we believe, from experience, that it is the best that can be desired, and as such we recommend it for use in Bombay, for no one of experience in India can suppose that a District Forest Officer can work well and enthusiastically if his Collector is allowed to issue Forest orders independently of him or that a Collector will take an interest in Forest work unless he is responsible for it. As we have ourselves had several year's experience of the Madras system, we can testify to its having, in our opinion, succeeded in doing what Sir D. Brandis wanted it to do. Of course, all Collectors are not alike, but we certainly found that most of those we had to deal with, under the pressure of Forest responsibility, developed a considerable interest in Forest work. Without their aid, the large areas of Reserved Forest now so carefully settled and demarcated, often in the middle of cultivated country, could never have been set aside as permanent forest estates ; nor could the management of the waste lands in general, and of the topes and scattered trees (which bring in a not inconsiderable revenue), and the protection of large areas from fire and from goat grazing, have been secured. The power of the Conservator was fully maintained, by giving him the full control of establishments and finance and by making it imperative on Collectors either to carry out his recommendations (usually made in consultation with them, however) or to give their reasons of objection and obtain a decision from the Board of Revenue. In the matter of *establishments*, we hear with regret that, as in other parts of India, matters have changed ; and in respect to *finance*, too, we understand that new orders have curtailed the Conservator's powers in this respect, the tendency in both cases being to make the Board the Head and the Conservator only an Inspecting officer. If we have been rightly informed, we can only say we think it a great mistake and that the sooner the authorities return to Sir D. Brandis' arrangements, the better. We do not want the Forest Department to degenerate into a mere subsidiary condition like the Salt Department or to see Forest officers employed in nothing but Police cases while their Forests are neglected and they themselves too discontented and sulky to do good work.

One paragraph in 'Velleda's' first letter has attracted our attention and that is one in which he advocates "the complete 'Imperialization of the forests.'" Surely 'Velleda' must know that such a thing is impossible and that were such an order issued, the very first day would almost bring his Divisional work to a dead lock. The Provincial Governments must have the control of the Executive and the Local Collector must be associated in the work. But that need not prevent, what we ourselves consider perfectly feasible and most advisable, and that is the establishment of an Imperial control in professional matters such as Settlements, Working Plans and Plans of Operations.

One of the matters which most urgently calls for reform in our Forest policy is that of making the Forest Settlement really legal and done in a similar legal manner and with the same formalities in all Provinces. What do we find, however? No less an authority than Mr. Baden-Powell who has been the acknowledged referee on all legal Forest questions for many years and who helped to pass the Indian Forest Act of 1878 and some of its successors, has recently told us in these pages that many of the so-called Settlements done in India are quite illegal; that the formalities prescribed by the Act have, in many Provinces, been totally disregarded; that rights have been constituted where there was absolutely no reason to load the State property with such serious burdens; and that, in short, the whole intention of the Act and its framers has been, purposely or not, evaded. We feel sure that in the North-West Provinces and probably also in the Punjab, most of the so-called Forest Settlement Work would not stand for a moment in a properly tried case before a High Court and we may doubt whether, in some other Provinces, it is much better, in spite of the oft-repeated warnings issued by the Government of India and the Inspector-General of Forests. In Bombay and Burma, we believe that the authorities have fully recognized the necessity of strict attention to procedure and strict accuracy in record and description, and we know that such is the case in Madras. It ought to have been the case everywhere.

Take again the case of Working Plans. How is it that many of our Working Plans are simple and easy and to the point and cannot but commend themselves to anybody, be he Forester or not, as valuable and important bases for forest management; but others have almost failed already, or if they have not failed, have had to be so modified in practice as to differ already considerably from their original form! Surely in this we want some further development, as it seems quite impossible that the Inspector-General, assisted only by a comparatively junior officer, who has a considerable amount of other work to attend to, should be able to cope with the important question.

Then, too, the systematizing of records, the collection of silvicultural information and the regulation of experimental works all require some further development at Imperial Head-quarters. In our opinion, an opinion which we have held for long, the professional side of the Department should be controlled by a Board, as it is in France and Germany, consisting of an Inspector-General and at least two Deputy Inspectors-General. One of these should have sole control of Settlement, and the other of Working Plans operations, while in other general matters and on the line of action to be taken in these, they should be deliberate as a Board. Then too, the Provincial work should be more systematic—the interference of Boards of Revenue and Financial Commissioners in all internal questions should be abolished; and the Conservator, if

there is only one, should hold to the Local Government the position that the Inspector-General holds to the Government of India. If there are more than one, they should form a Board of advisers under the local Revenue Secretary. Divisional officers should, whenever possible, be, as in Madras, Assistants to the Collectors; and in those places where this is not feasible as it possibly may not be in some localities, they should be under the Conservators, but obliged to consult the Collectors on every important question which concerns them in the least.

The Imperial consulting Board would travel all over India, not together, but to those places where the special subjects of each were most important: and their reports on professional subjects should be passed by the Government of India, and sent to Local Governments to be carried out; while those on other subjects should be submitted to the Local Governments for such action as they might think necessary, the understanding being that the recommendations should be carried out, unless sufficient reasons existed against them.

In the same way, the Conservators would control the local works in a lesser degree, reporting to their Governments, who would issue their orders to the Collectors concerned. Below the grade of Collector, no Revenue or other official should be allowed to interfere, but the District Forest Officer should, under the Collector's orders and supervision, carry out the Conservator's instructions and supervise the forests and their staff and finance.

On Pruning.

(From the *Révue des Eaux et Forêts*.)

As a first principle, trees do not require pruning, but if this principle is observed in our forests it is not so everywhere and there are localities where it is impossible to move about without seeing on all sides ugly wounds called pruning sections. These sections or cuts are extremely varied, either leaving a stump or close to the stem, the cut may have been made tangentially or having a plane section, with or without coal tar, but in all cases there is degradation of the subject from which large branches have been removed.

Leaving aside many curious facts regarding the natural shedding of branches by young trees, which have, as yet, been but imperfectly explained, we will confine ourselves in the present season, the one most favourable (March-April) for prunings which extend into the living tissues, to the best method of procedure in such cases.

First it may be desired simply to reduce the length of certain branches without removing them entirely. A friend of the writer had a walnut tree from which, becoming troublesome to a neighbour by an enormous development of low branches, he was obliged to *prune, cutting* two of these which were main branches; this occurred fifteen years ago. The walnut is known to be very susceptible to wounds of this nature and the owner was afraid of endangering the future of his tree, he restricted himself, therefore, to sawing off the two branches at something over three feet from the stem, almost directly under the extremity of the top branches. The section of each of the cut branches had a diameter of from $4\frac{1}{2}$ to $5\frac{1}{2}$ inches and the tree then lost something like one-sixth of its foliage. At this time, the walnut, which was a very vigorous tree of about 40 to 45 years old was adding 3 centimetres, or over an inch, a year to its girth. The owner, who measured the tree every year, was surprised to find that during each of the three years succeeding the pruning, the walnut only grew one centimetre in girth instead of three, then the tree recovered its former vigour and resumed the previous increase of three centimetres a year. The extremities of the stumps of the two amputated branches had covered themselves with numerous branchlets—which have continued to develop. The crisis lasted in this case for three years.

It may be required to cut off entirely branches which are already large from trees isolated or planted in lines, growing in a park, or garden, or in the neighbourhood of habitations, and even occasionally from trees growing in a forest. In such cases, to avoid damage to and decay of the tree, one may proceed as follows, imitating as far as possible the process of the natural shedding of branches under thick cover. Cut off half the branch and girdle it at the base. The reduction of the length of the branch by a half does not require any great care, as it is eventually to disappear entirely and the object of the girdling is as follows. Near to the trunk at the point where the swelling of the base of the branch ceases, a ring of bark at least four inches long is taken off. The removal of this ring prevents the further growth of the part so exposed and tends to provoke the immediate formation of a callus at the base of the branch. Time must then be allowed for the branch to disappear naturally; if it should regain its vigour or if bark should form again on the girdled portion, it will be easy to come back after three years and again reduce and girdle the branch. The cushion or collus formed at the base squeezes and encloses the barked wood in proportion as this wood becomes altered and prevents water entering into the trunk of the tree. Those natural prunings which leave the tree sound come about in this way.

If instead of restricting oneself to removing a ring of bark, the wood were to be lightly notched at the base of the girdled portion, the operation would be accelerated. The callus would

promptly cover the notched wood and after this had taken place one could finish the operation by removing the remainder of the branch. This method allows access to moisture into the tree and is the more dangerous as the notch is made deeper, the vigour of the subject less and the species more susceptible to injury.

For the Oak, at least, the principle to be applied and which has been set forth by M. Nanquette at the Forest School at Nancy for some time past, may be abbreviated thus.—Ne touchez pas à la reine.

(C. B. in the *Revue des Eaux et Forêts* for April 10th, 1892. Translated by A. F. G.)

II.—CORRESPONDENCE.

Teak in Travancore.

DEAR SIR,

In connection with Mr. Moss's interesting letter on the germination of teak in the May number of the Indian Forester, perhaps a few remarks may not be out of place.

I have often noticed the difference mentioned by Mr. Moss in the appearance and texture of the leaves of teak, but I have always been under the impression that this difference was entirely due to age. When teak is quite young, its leaves are scabrous, serrate, and obovate or even spathulate, and at this stage they often resemble the leaves of *Dillenia pentagyna*, but after 5 or 6 months the leaves become glabrous, of a darker colour, and ovate. The young shoots of old trees often have scabrous obovate leaves. I shall be glad to hear if Mr. Moss on further study of the subject still retains his opinion as to the existence of two varieties of teak.

As regards the germination of the seed of this tree doubtless vast quantities of fine seed are burnt every year by grass-fires, but in the moist and forcing climate of Travancore all our forests are full of young seedlings, and their vitality even after being burnt is astonishing. In a dry climate, the method suggested of sowing seed in contour lines and of digging up the soil under seeding trees should give very good results.

We have been doing some planting this year, and I find that April is too late for sowing seed in nurseries, that is to say April

sown seed will give plants fit to plant out only in August or September. If the climate is very wet and plants will strike at once, the seed should be sown in February, but I have been most successful with stumps and prefer them to anything. The best size is a little thicker than a lead pencil, and seed sown in January should give plants of this thickness.

The growth of teak compared with tea or coffee is perfectly marvellous. Within ten days of being put in, stumps throw out buds, and in a couple of months the shoots are from one to two feet high, whereas coffee takes two and tea six months to make any start.

In our forcing climate, teak rushes up to ten feet in the first year, which makes it liable to be blown over by the wind. The old system was to strip off all the leaves, which indeed made the trees less liable to be blown over then, but it retarded their growth for a time and the trees shoot up and become more top-heavy than ever the next year.

In such cases of rapid growth it would probably be better to cut the trees back or to plant closer. But we are giving up these low-lying forcing valleys for the open hill side.

Quilon.

T. F. B.

August, 19th 1892.

Improvement of the Indian Raspberry by cultivation.

SIR,

I enclose a cutting taken from the *Queenslander* giving an account of the successful introduction into Australia of the yellow bramble or raspberry (*Rubus flavus*) so common around Mussoorie. I think it a fruit that would improve under cultivation, and by drawing the attention of forest officers and others to it through the medium of the *Indian Forester* some may be induced to try experiments with it.

In a wild state, I have noticed that the fruit varies greatly in size and flavour. When commencing operations, I would therefore advise beginning from seed, collecting the latter from bushes which possess superior-sized well-flavoured fruit.

“ In the annual report of the Queensland Acclimatisation Society attention is directed to an Indian raspberry (*Rubus flavus*) which has been successfully introduced into different parts of the colony. The report states that the plant was first grown from seeds received from the Botanical Gardens,

‘ Saharanpore, India. Several plants of this raspberry were raised, and during the past year the specimen plant that was placed outside has fruited. The plant grows most luxuriantly, and fruits freely. The fruit are borne on the terminal shoots of the current year’s growth and form loose panicles, containing from six to eighteen separate fruits on each ; they are of a pale yellow colour when ripe, and possess the full raspberry flavour, with a delightful sub-acidity which renders them most palatable when eaten raw. A small quantity were made into jam, which turned out well as regards flavour, but the colour was not desirable ; this could, of course, be overcome by the addition of colouring matter. Several plants have been sent to various parts of the colony, and seem to thrive equally in inland, upland, and coast land localities. It is a plant of very robust growth, making shoots from 1 in. in diameter at the base, and from 8ft. to 12ft. long. It is most easily propagated from layers, and needs no particular treatment in cultivation. From its strong growing habit and the fact that it is armed with formidable spines, it is a most suitable plant for placing round the boundary fences of orchards to exclude marauders. In appearance the plant is rather ornamental. It is ever-green, with very pretty soft green foliage, the young shoots being clothed with a dense mass of beautiful dark-red downy-looking hairs. Experiments are being carried out with the plant as regards how it will bear pruning, the idea being to see whether it will increase or diminish its fruit-bearing qualities. If it will stand hard cutting, its value as a fence plant will be considerably increased. The society have a stock of plants ready for distribution, and recipients are admonished to give the plant a fair trial and report results.”

W. GOLLAN,
Supt. Govt. Bot. Gardens,
Saharanpur.

Note on the reproduction of Shisham.

Your correspondent C. F. E. in the August number refers to the reproduction of *Quercus Ilex* by means of the extraction of the old stumps. Does this extraction *really* encourage the growth of root-suckers, and if so why ? Some time ago I had occasion to deal with the reproduction of Shisham. Going on the well-known fact that it will not reproduce itself from seed under its own cover, and perhaps also, requires quite fresh river-born soil—I merely went in for clean coppicing. The result was extraordinary ; the stumps (some being very large) sent out perfect

bushes of coppice shoots which attained 4 or 5 feet in four months (owing to the hot weather) and were about 10 to 15 feet high at the same time in the following year, but *in addition* there were many root suckers scattered about between these coppice bushes. Whether or not smashing up the stumps would encourage these root suckers I do not know, nor even whether they continued to exist, but that the felling produced a crop of them was very clear.

T.

Fires Caused by Bamboo Friction.

In the article which appeared under the above heading in the August issue of the "Forester" it is stated that "We all know that forest villagers light their fires, etc: by rubbing two pieces of dry bamboo." Personally, I have never seen this done, have never met any one who has seen it done, and up to the present believed it to be an impossibility. That it is possible to produce fire by the friction of wood on wood, or of bamboo on bamboo, is well known, but the success of this process, depends in the production of very finely divided wood powder which owing to its extreme dryness and minute division ignites at a temperature which may be produced by friction of wood. The apparatus used to create fire by this elementary method consists of one piece of wood in which a cup-shaped hollow is cut, and of another, with a pointed end which is made to revolve like a drill in this hollow. Given absolute dryness of the material and skilful manipulation as regards speed and pressure, a fine wood powder is formed which ignites when the heat caused by friction is sufficient. The momentary incandescence thus produced must be promptly transferred to a more inflammable material such as tinder, from which a fire can ultimately be created. It appears to me to be almost impossible that such a combination of circumstances should naturally occur, which, in a high wind, would result in the creation of a momentary spark and in its transfer to suitably inflammable matter; and quite impossible that the fitful friction, the result of variable wind action on the exterior of two bamboo stems should cause these stems to spontaneously burst into flame. It would be most interesting if E. D. would send for some forest villagers and report to the "*Indian Forester*" the procedure followed in producing fire by rubbing pieces of bamboo together; he might then provide the villagers with pieces of dry bamboo *in the round* and record how long was taken to produce fire by friction in the most favorable circumstances; the

absence of wind, which removes the inflammable powder produced by friction, and regular non-intermittent friction of course giving the forest villager an advantage over nature. Such experiments would set at rest the vexed question of Friction Forest Fires.

S. E.-W.

We may mention that some years ago, in 1874, we think, we saw a Lepcha in the Darjeeling Hills obtain fire easily by rubbing briskly a pointed dry bamboo in a nick in another piece where some bamboo dust had been collected as tinder. Perhaps some of our readers can give other authentic instances. As for two bamboos rubbing against each other in the wind producing fire, we can only express our absolute disbelief in its possibility.

HON. ED.

III.—OFFICIAL PAPERS & INTELLIGENCE.

Good Conduct Badges.

The following Resolution of the Government of India may interest some of our readers.

“On consideration of the observations recorded by Local Governments and Administrations in reply to a Circular issued in July, the Governor-General in Council is pleased to decide that the bestowal on Forest Rangers of any such distinction as that proposed is unnecessary; and that as regards officials of lower rank, Local Governments and Administrations may adopt, if they so wish, a system of awarding “chevrons” for approved service and good conduct, the chevrons to be worn on the coat-sleeve up to a maximum of three per man.”

Budget Estimates of the Forest Department for 1892-93.

In our May No. we gave the figures for 1891-92 and those adopted by the Finance Minister for 1892-93. We now give the accepted detailed figures for the latter year.

PROVINCES.	1890-91.			1891-92.			BUDGET ESTIMATES, 1892-93.		
	ACTUALS.			REVISED ESTIMATES			FINALLY SANCTIONED BY GOVERNMENT OF INDIA		
	Receipts.	Charges.	Surplus.	Receipts.	Charges.	Surplus.	Receipts.	Charges.	Surplus.
	Rs.	Rs.	Rs.	Rs.	Rs.	Rs.	Rs.	Rs.	Rs.
" Imperial		84,050	—84,050		73,000	—73,000		91,000	—91,000
Bengal	7,27,390	4,18,330	3,14,060	8,15,000	4,20,000	3,95,000	8,32,000	4,81,000	3,51,000
North-Western Provinces and Oudh	16,37,880	9,05,940	7,31,940	17,33,000	10,34,000	6,99,000	17,20,000	10,20,000	6,73,000
Punjab	8,34,370	6,49,950	1,84,420	10,10,000	6,70,000	3,40,000	9,50,000	7,10,000	2,40,000
Central Provinces	12,13,460	7,33,620	4,79,840	13,36,000	7,81,000	5,55,000	12,75,000	9,36,000	3,39,000
Lower Burma	26,77,670	10,86,480	15,91,190	27,82,000	13,35,000	14,47,000	26,20,000	13,64,000	12,56,000
Upper Burma	16,44,800	8,01,460	13,42,840	13,00,000	4,00,000	9,00,000	20,50,000	4,90,000	16,60,000
Assam	3,26,790	2,73,490	53,300	3,29,000	2,72,000	57,000	3,48,000	3,26,000	22,000
Coorg	1,35,560	65,750	69,810	1,72,000	99,000	73,000	1,19,000	89,000	30,000
Ajmere	15,270	12,720	2,550	19,000	14,000	5,000	14,000	14,000	-
Baluchistan	15,720	24,470	—11,750	21,000	32,000	—11,000	35,000	50,000	—12,000
Imperial Forest School	1,180	35,190	—34,010	1,000	46,000	—45,000	1,000	48,000	—47,000
" " Survey	2,100	24,320	—22,220	-	23,000	—23,000	-	23,000	—23,000
Andamans	1,58,330	1,30,050	28,280	2,11,000	1,38,000	73,000	2,82,000	1,88,000	94,000
Madras	17,95,410	12,39,210	5,56,200	18,00,000	13,85,000	4,15,000	19,00,000	16,08,000	2,92,000
Bombay	82,88,220	18,56,730	14,31,490	34,44,000	20,74,000	13,70,000	35,17,000	22,89,000	12,78,000
Berar	4,87,110	1,68,920	3,18,190	5,05,000	2,04,000	3,01,000	5,03,000	2,40,000	2,63,000
TOTAL ..	1,49,60,760	80,08,680	69,52,080	1,54,78,000	90,00,000	64,78,000	1,61,69,000	99,44,000	62,35,000

IV.—REVIEWS.

The influence exercised by the season of felling on the production and development of coppice-shoots by
E. Bartet, Inspector of Forests, Nancy.

The above influence has always been recognised as important by authorities on forestry, without any definite proof being produced in support of their opinion. In this pamphlet, M. Bartet gives the results of certain practical researches, made in order to obtain the proof needed.

Four experimental areas were selected in a portion of the Forêt de Haye near Nancy, under coppice with standards. The coppice rotation was formerly 25 and latterly 35 years, so that the standards are respectively 60 and 85 years of age. These plots were on flat ground, numbers 2, 3 and 4 being contiguous, whilst number 1 was distant from them about half-a-mile. Each of these areas was sub-divided into several small plots, No. 1 into seven and the others into six each, their average extent being two acres.

The investigation was limited to the commonest species viz: Oak (*Q. sessiliflora* and *pedunculata*) hornbeam and beech, and to a certain number of stems only. These stems were selected as follows:—

1. In each plot and for each species two standards 85 years of age (*anciens*), two standards 60 years of age (*modernes*), four isolated poles and four coppice clumps 35 years of age.

2. In the same experimental areas, clumps were selected, for the most part possessing the same number of stems.

3. Finally, the standards were chosen, as far as possible, of the same size and vigour for each category.

Owing, however, to the scarcity of hornbeam and to the irregular distribution of beech, these rules had to be disregarded in many instances. Each clump, whatever its number of stems, was taken as an unit and given a single number. The stems selected were felled in the middle of March for the plots numbered I, in the middle of April for those numbered II and so on to the single plot No. VII which was felled in the middle of September. Experimental area No. 1 was felled in 1883, No. 2 in 1886, No. 3 in 1887 and No. 4 in 1888. The coppicing was done most carefully, the stems being cut close to the ground and well protected from all damage.

The three chief points observed were—

- (1). Date of appearance of the new shoots,
- (2). Facility with which the stools produced shoots.
- (3). Number, nature and height of the new shoots.

(1). *Date of appearance of the new shoots.*

All the shoots on a stool do not appear at the same time but a certain interval elapses between the appearance of the first and the last, and these dates depend, not only on the date of felling, but also on the constitution of each individual clump. The following are the results obtained for each species :—

(a).—OAK.

Plots Nos. I and II., coppiced from the middle of March to the middle of April.

First shoots appeared towards end of May. Three-fourths of the stumps produced shoots before the middle of June, and almost all before the end of August.

Plot No. III, coppiced in the middle of May.

First shoots did not appear before the beginning of June, and at the middle of this month only about one-half the stumps shewed signs of activity. 11 per cent., mostly from the old standards, laid dormant until the following spring.

Plot No. IV, coppiced in the middle of June.

Shoots began to appear early in July, and most of the stumps became active before the middle of August, 11 per cent. lying dormant until the following spring.

Plot No. V, coppiced in the middle of July.

70 per cent of the stumps produced shoots before 15th of August, and over 80 per cent. by the end of the first year. On the other hand, 18 per cent, remained dormant until the spring.

Plot No. VI, of experimental areas Nos. 2, 3, and 4, coppiced in the middle of August.

About half the stools became active the same year, some in August, more in September. But even on those stools which became active before winter, the majority of shoots were produced in the following spring.

Plot No. VI, of experimental area No. 1, felled at the end of August.

Out of 10 stools, one only produced shoots before winter, eight became active in the spring following, the tenth not until the second spring.

Plot No. VII, coppiced in the middle of September.

No shoots appeared before winter, the stools not sprouting until the following spring, chiefly in May and June.

It seems therefore that the end of August is the date beyond which shoots of oak will not be produced until the succeeding year.

(b).—HORNBEAM.

Hornbeam, when coppiced, acts in a slightly different manner from oak. In the first place, in the case of stools coppiced from the middle of June to the middle of August, a larger number remain dormant until the spring. In the second place, the period during which new shoots are produced from the same stool is longer than in the case of oak; so that, when the coppicing has been done in March, April and May, not only are new shoots emitted up to the middle of August as in the oak, but right on to the close of the season of vegetation. These differences are due to the hornbeam producing fairly numerous adventitious shoots which naturally take some time to form, and in consequence, appear about two months later than the others.

(c).—BEECH.

The action of beech resembles that of hornbeam, but differs in the important point of producing more adventitious shoots, many stools producing these alone. It follows that beech stools become active later than those of hornbeam. Nevertheless, if the coppice is made before the 15th of June, the greater part of the shoots will be produced before winter. If coppiced in July, only half the stools will become fertile before winter. If in the middle of August, no adventitious shoots will be produced until the spring.

2.—*Facility with which the stools produce shoots.*

The stools observed behaved in three different ways.

1. Some never produced any shoots.
2. Others became accidentally sterile.
3. From others, shoots appeared and established themselves.

1. Tables are given shewing the percentage of stools remaining unproductive, arranged according to the months of coppicing; but, owing to the too small number of stems operated on, not many useful deductions can be drawn. Suffice it to say that the percentage of the inert stools, irrespective of the felling season, was found to be :—

Oak	12
Hornbeam	5
Beech	19

2. It was found that 11 per cent. of the oaks coppiced in the autumn, lost their shoots by early frosts, whereas the beech suffered more in the spring from the effects of drought; but here again the percentages are not trustworthy, for the cause mentioned above.

3. Oak and hornbeam were found capable of producing shoots up to 60 or even 85 years of age.

3.—Number, nature, and height of the shoots.

Owing to the limited number of standards felled, accurate conclusions can only be drawn from the coppice clumps cut. The oak practically produces proventitious shoots only, for out of 4,132 shoots, four alone were adventitious ones. The beech and hornbeam, on the contrary, produce a large number of adventitious ones, the beech about an equal number of each kind, while the adventitious shoots of the hornbeam are only about 12 per cent. of the total number.

The following conclusions have been arrived at from the observations made:—

(1.) By felling the hornbeam in full leaf, the proportion of stools bearing only adventitious shoots is largely increased.

(2.) By felling beech in full leaf, the number of adventitious shoots is trebled, and the number of fertile stools doubled.

(3.) The largest number of adventitious shoots is obtained by felling the beech in June and the hornbeam in July.

(4.) The average height of the shoots is much greater when coppicing takes place in the spring than in the autumn, the young shoots in the latter case suffering from frosts, and the stools not being then so rich in alimentary material. For example, at the end of the second year, the shoots of those oaks coppiced in April, averaged three feet in height, whereas those coppiced in the August before were nearly half a foot shorter.

The pamphlet is admirable as shewing how such observations should be conducted, and the minuteness and care necessary to obtain any trustworthy data on such subjects. Considering, however, the great trouble that has been taken, it is much to be regretted that many of the deductions, and a great number of the tables should be practically valueless, because observations were made and measurements taken on a very insufficient number of stems. It seems to be the common fate of so many experiments to be conducted on too small a scale.

If any similar experiments were made in India, they would have to be modified to suit the country.

The time of felling is here often limited by climatic conditions; on the higher slopes of the Himalaya, no work can be done during the winter season when the forest is blocked with snow; along the foot of these hills again the rainy season puts a stop to labour; and in the greater part of our Indian jungles the working season lies between October and June.*

Practically, however, there is the important consideration that if the produce coppiced be saleable, it is imperative to dispose of the whole of it during the working season and before the

**Note.*—In our experience, work goes on all the year round, in one way or another, almost everywhere; though in some places in the North-West it is slack in the rainy season, especially where there is no planting to be done.

rains. This requires us to coppice in January or February at the latest.

Again, some species lose their leaves during the hot weather, and some during the cold season, so that the most suitable time for coppicing might not be the same for both categories. The effect of drought on the young coppice shoots during the hot season requires to be studied, as well as (in Northern India) the effect of frosts in January and February. Theoretically, the best time for coppicing would probably be after the time of frost and so late that shoots would not be produced until the rains set in; so that both the effects of frost and drought are minimised, as well as the danger from fire.

Unfortunately, in India, the ages of the trees are seldom known. It would be best, therefore, to test the coppicing power of selected species of certain girth instead of age classes.

We trust that these few remarks will induce Forest Officers to make investigations into the growth of coppices under their charge, and to publish the results of their research in the pages of this journal.

Annual Progress Report of State Forest Administration in New South Wales for 1890.

Mr. J. Ednie-Brown was appointed Director General of Forests in New South Wales on the 1st July 1890, and his first annual report is dated 1st September 1891. It contains, including Appendices, 63 pages of closely printed foolscap, and is divided into 21 sections. The first six pages constitute an essay on the State conservation of forests, and on the effect of forests on rainfall, climate, &c., and are by way of a general introduction. Then we have recommendations for the re-organisation of the Department, the staff proposed, and the powers of the Director General, one of the proposals being that he shall appoint all the officers of the Department! It is proposed that the Colony should be subdivided into three or more districts, over which Conservators of Forests should be appointed; under them come Foresters, Forest Guards, Nurserymen, and labourers. There is also to be a consulting botanist; and to take the place of a Conservator, Forester or Forest Guard, proceeding on leave, there is to be a relieving officer. The proposal of Mr. Brown is that a permanent post on the Staff be created for this purpose, *viz.* to take the place of any one, no matter apparently of what grade, proceeding on leave. This is a contrivance that may be necessary, but officiating appointments are evidently unknown in N.S. W.

Certain proposed new regulations are then treated of which we need not discuss, and this is succeeded by a section on a proposed School of Forestry, Museum, and (of course) Arboretum. It is suggested that this School could train Foresters for the sister colonies as well: and the subjects to be taught are as follows:—

“The inside instruction would consist of matters in connection with the following subjects:—

- ‘1. Arithmetic.
- ‘2. Geometry.
- ‘3. Mensuration, surveying, and planning.
- ‘4. Forest mathematics and the measurement of trees and
‘timber.
- ‘5. Erection of buildings.
- ‘6. Water conservation by dams, wells, tanks, etc.
- ‘7. Forest botany.
- ‘8. Physiology of tree vegetation.
- ‘9. Forest chemistry.
- ‘10. Formation and nature of earth and soils.
- ‘11. Forest conservation.
- ‘12. Forest laws.
- ‘13. Forest administration.
- ‘14. Correspondence and general routine of office work.

‘The outside or purely practical work, would consist of the following:—

- ‘1. The selection of the tree seeds.
- ‘2. Their treatment before sowing.
- ‘3. How to sow them.
- ‘4. When to sow them.
- ‘5. Treatment of the young plants.
 - ‘a. Deciduous.
 - ‘b. Evergreen.
 - ‘c. Indigenous.
 - ‘d. Exotic.
 - ‘e. Hardy.
 - ‘f. Tender.

‘The formation of an Arboretum, and in connection with this, special attention would be paid to—

- ‘a. Soil suitable to each species.
- ‘b. Situation and aspect suitable for each kind of
‘tree.
- ‘c. Treatment as regards thinning and pruning.
- ‘d. The general management of plantations with
‘various stages of their growth.

‘The felling of trees and the various methods in connection with this operation.

- ‘6. The measurement of standing and felled timber in the
‘rough.

'7. The measurement of timber by cube, superficial, and 'lineal processes.

'8. The economy and utilisation of the timber.

'9. Practical surveying.

'10. Drawing.

'11. Ploughing.

'12. Hole sinking.

'13. Fencing.

'Practical planting of plants raised under the following systems :—

'a. Open root.

'b. In bamboo tubes.

'c. In pots.

'The formation of plantations by the system of sowing the 'seeds in the sites which the trees are intended to permanently 'occupy.

'a. By broadcast sowing.

'b. In drills.

'The sawing of timber for various purposes, with a view to its 'proper utilisation ; the most economic methods for the transport of 'timber to the saw-mill and to market ; the proper manner by 'which to protect plantations by brakes from their possible 'destruction by fire."

The above list is worthy of attentive study. As far as we can see, there is nothing about Sylviculture : not one single word about the natural regeneration of forests by self sown seeds, and yet this is a subject worthy of *some* study ! The teaching staff is to consist of the Director General himself who would take up six subjects ; a Principal whose duties would consist in teaching mathematics, surveying, chemistry, &c. ; a professor of general sciences— whatever that may mean— ; and a practical expert on all outside work. The course of instruction is to last one year only. What leisure the Director General is to find for travelling about and inspecting the various forests is not stated, but possibly this is not one of his duties. One of the features of the school is that the students are to do five hours out-door work every day for 200 days in the year and are to receive 6d. an hour for such work, and thus, to a certain extent, to pay their way. We suppose this work would be done in the Arboretum.

Since the Forest Conservancy Branch was instituted in 1877, the total revenue has been £179,000 while the expenditure amounted to £184,900, shewing a deficit of nearly £5,900 ; the greater portion of this deficit was incurred during 1890, the excess of expenditure over revenue up to the end of 1889, having only been £540.

It appears that grazing dues are not credited to the Forest Department and if they were, there would be a handsome surplus, and Mr. Brown is of opinion that were these lands set apart for forest purposes, permanently made over to the Department and

managed by it in its own way, a much larger revenue would be the result.

The total estimated area under Mr. Brown's jurisdiction amounts to 5,459,937 acres, or about 8,531 square miles; the localities are given, number of reserves (total 945) in each locality, and the name of the Forest Ranger in charge. Some of the reserves are small, *i.e.*, under 1,000 acres. No mention is made as to how these reserves are demarcated.

In succeeding sections are noticed the work done by the consulting botanist who has begun to get the museum and herbarium into order; donations of seeds, &c., during the year; the importance of State nurseries, a list of the 712,000 available plants in the Gosford nursery; the science of wattle cultivation, and an account of the cedar forests (*Cedrela australis*) from which we extract the following:—

‘The wood is easily worked, comparatively light in texture, fairly durable, and is largely used in the construction of furniture, general house decorations, and other purposes where the lightness, beauty of grain and capability of taking a fine polish are necessary.

‘The tree attains a height sometimes of over 180 feet, and from 4 to 10 feet in diameter. As a rule it is deciduous, umbrageous when allowed sufficient room to expand its branches, and is generally handsome in appearance. Its congener, the *Cedrela Toona*, indigenous to India, is also well known in the timber market as a wood of great commercial value, which is used for similar purposes as those referred to.

‘Owing to its very great value, the indigenous forests of *Cedrela australis* have been largely worked upon, and owing entirely to inadequate regulations and supervision by the State, they have been, to a very large extent, ruthlessly destroyed; and although not beyond the means of renovation both by natural regeneration and planting, it will be a matter of very careful and special application for a considerable number of years before their previous original excellence can be attained.

‘In consequence of the very lax regulations and of the value of the timber and the general demand by the trade, large quantities of this timber were at times felled by the so-called and well known “cedar getters” in almost inaccessible situations, with the view at some future time of being able either by floating it down creeks and rivers when floods occurred, or by opening up the country by settlement, through the construction of roads, to reach a market.

‘In many cases, and unfortunately they are very many, the necessary means in the way indicated towards the transport of the logs did not occur; or, at least, were delayed so long that the timber thus cut became thoroughly water-logged and otherwise decayed so as to become to a very great extent worthless and hence unmarketable.

' In this way it is not too much to say that millions of superficial feet of this, the most valuable of all our indigenous timbers, have been wantonly wasted, and consequently tens of thousands of pounds not only in royalty, but in value of actual produce have been lost to the country."

Proposals with regard to forming plantations of Red Cedar and to tending and renovating the indigenous forests follow:

Natural regeneration, we are glad to see, is not altogether lost sight of, as the following extracts show:

" Where natural regeneration of this kind takes place, the re-foresting of a tree by this means is of great importance, and should be carefully attended to, and encouraged in every possible manner. On such of the reserves, therefore, where this has taken place, it is the object of the Department to give this natural regeneration special attention and assistance, as it is a well known fact that when trees grow up in this manner they have a better chance of giving satisfactory results in regard to growth and quality of timber than those trees reared by artificial means. It is consequently proposed that, as regards these trees, their care and proper supervision will have the special attention of the Department. In order to protect such portions of these reserves as are not already naturally protected by the density of the scrub against the inroads of stock, it will be advisable to thoroughly fence them.

' Should the system be carried out upon an extensive scale, this matter of fencing will, no doubt, entail considerable expenditure, but the results will eventually amply justify the cost.

' In dealing with such tracts of country, it is proposed for a few years to go carefully over the ground and clear away all underbrush which may be interfering with the proper health of the young cedar plants; to thin out these, where they are found growing too thickly together; and, in some instances, to ring-bark such of the worthless trees of other kinds as may be found overshadowing, and thus retarding the growth and proper development of the young cedar; which it is desired should be assisted to come on as the permanent and most important crop. Of course, it will be found in work of this kind that the cedars have come up in a very intermittent and irregular manner, hence many spots in the forests highly suitable for the production of the species will be unoccupied by them. It will therefore be a matter of detail for the foreman in charge of the work to have the thinnings referred to, transplanted out into such vacant places, as the work progresses, and these sites treated in a similar manner as regards undergrowth and useless trees, as these left standing.

' In this way it will only be a matter of time and application to regenerate these forests of cedar in a more systematic and regular manner, than they were originally.

' Whilst looking to the natural reproduction of the tree, to which reference has just been made, for its out put of cedar

‘timber, it will be necessary, I think, to supplement this by the formation of regularly formed plantations, and with this object in view the Department has, as a preliminary step, already raised over 100,000 red cedar plants at the Gosford State Nursery.’

The suggestions given in the above paragraphs are most valuable, and we trust that this matter will not be forgotten in the teaching at the proposed Forest School.

An interesting account of the red-gum forests of the Murray river is given in Section XII, and it is stated that their natural regeneration is a simple matter, and that thinnings have already been commenced in the young crop, and a million strong young trees set free.

Section XVI is devoted to “Timbers suitable for engraving purposes” and the following remarks shew that Mr. Brown is sanguine as to the ultimate success of these timbers:—

‘There is abundance of timber in the forests of New South Wales suitable for engraving purposes, indeed it is now growing to waste everywhere, but it is difficult of access and will require a lot of careful handling and preparation before it is likely to supplant the finer qualities of imported wood-engraving timber from Turkey, Persia, and India, which have been growing scarcer and more expensive in the open markets of Europe during the last few years.

‘A great market might be established in Europe for Australian timbers suitable for engraving purposes, now that the old sources are being exhausted, if someone would only take the trouble to select the most suitable timbers for the purpose and mature them. The result would undoubtedly be a national benefit.

‘Some experiments have been made in this direction during the last few years, but they have been intermittent and inconclusive, and it yet remains to be shown that our timbers may be profitably utilised on a large and comprehensive scale for this particular purpose. Morally, there is very little doubt about the matter; practically, very much still remains to be done.

‘A large proportion of timbers of the Clarence, Tweed, and Richmond Rivers districts are equal in quality to those of the forests of Turkey and Persia, and even of India; but they require careful scientific treatment before being taken into the markets for comparison and competition, and this consideration has been notably absent in the past. Experience has shown that while the timbers possess all the necessary good qualities, we lack the training and experience which is necessary to mature and treat them as they do in the old world. With a little care, however, it would be possible to place at least a dozen of our timbers on the European market as suitable for the best description of wood engravers’ work, with an almost certain assurance that they would favourably compare with the best Turkish boxwood.’

A list of timbers already tested follows.

Lastly we may notice the bringing out of an Illustrated work upon the Forest Flora of the Colony, the first number of which is expected to be ready in June 1892; and the introduction of exotic timber trees, such as walnut, oak, pine, fir, &c., to supplement the indigenous timbers, which, though very durable are in many cases too heavy for certain constructive purposes. The wisdom of this step can only be proved by experiment; the questions are, can these trees be grown successfully on a large scale in the Colony? If so, will their timbers retain the same qualities which they possessed in their natural home, and will they be able to compete with indigenous timbers in every respect?

We should like to see among other things in the next Annual Report, a map shewing the localities of the reserves, with some detailed account of the working of any one of them, say the Moira State Forest in Cadell county; less about plantations, nurseries, and exotic trees and more about the status of the reserves; what is meant by Class A, Class B, and Class C; what rights has the State over them; and to what extent can outsiders step in? Meanwhile, we have to thank Mr. Brown for a very interesting report on a subject that is little known.

A. S.

Peach culture in Simla District.

We have received from Mr. W. Coldstream, C. S., Superintendent of Hill States, Simla Tract No. 8 on the advantages of cultivating peaches. Considering that three persons if not four were associated in its production, we are somewhat disappointed by this meagre pamphlet of six pages, even though we see that it is printed and published for the edification of Local Zemindars. After describing the advantages of having trees planted round houses, the conclusion is arrived at that the *peach* is the best tree to plant as "it grows rapidly—comes to maturity—or fruit bearing—in three or four years—is most easily cultivated 'from the seed and is usually very prolific.'" We are then told that "in very rich soil trees six years old have yielded one thousand peaches each in a single crop," and here at the outset we find ourselves obliged to protest. Any one who has ever tried it, even on poor soil, knows that one can get lots of peaches, but that to get good peaches, not the rubbishy bitter little hard green peaches of the villages, you must obtain the best kinds, must cut off about three quarters of the fruit when set, must prune carefully and manure heavily and these are just what the villagers will not do. No doubt, on the outskirts of hill villages, manure of a sort!—is plentiful, only too plentiful, but who ever heard of a native fruit grower cutting off any of the

young fruit to improve the rest, any more than he heard of a native gardener who would of his own accord gather his peas before they were as hard as bullets, or his turnips until they were more fit to give rope-fibre than food.

No doubt, peaches, if only some attempt is made to get good ones, are good things to grow, and even when hard and bitter they make good stew; but there are other fruits as good, such as apricots, Bokhara plums and above all, apples. It seems to us that there is no want of fruit trees generally in the North-West Hills but that what is wanted is improved cultivation and consequent improved quality. Hints on these important matters are unfortunately absent from Mr. Parsons' 'directions for sowing and rearing' which we need hardly reproduce, as they contain nothing but what any Forest officer must have known long ago.

We take the greatest interest in the work with which officers like Sir Edward Buck and Mr. Coldstream have identified themselves, but we hope that in future Tracts of the kind, Mr. Coldstream will impress upon his Ranas and Zemindars the advantages of improvement in quality as much as those of increased number of trees.

V-SHIKAR.

Hollow-fronted Bullets and Large Game.

SIR,

Many of your readers will have seen in recent issues of the *Field* a somewhat animated discussion on the effect on large game of Express Rifles used with hollow fronted bullets. The question has remained practically undecided owing perhaps to the limited number of Sportsmen in England who are interested in the matter; but it is of sufficient importance to invite discussion in the *Forester* especially to men like myself who are more or less addicted to solitary rambles through the forests, for when several sportsmen band together to bag dangerous game, it is immaterial what weapons they use. In the days of my youth I possessed what was called a D. B. .577 Express Rifle which fired a short hollow-fronted bullet with a charge of 4 to 4½ drams of powder. This weapon I found most deadly when used against the larger forest animals such as sambhar and tiger; the penetration was good, the bone-smashing qualities excellent, and in one happy summer, I killed with it five tigers in six days, each with a single shot. The reason for this success

is not far to seek. I used bullets of soft lead which travelled with a low velocity owing to the small powder charge and as they were not reduced to powder on impact, the penetration was good. After a time, however, finding that the high trajectory of the bullet was not conducive to fine shooting, I replaced my .577 rifle by a .500 Express by Henry, which fired a charge of 5 drams behind a hollow-fronted hardened bullet, and my troubles began at once. I found I had gained enormously in accuracy but had lost equally in penetration! The smaller deer and antelope were indeed quite helpless when struck with this bullet, and even the larger deer and tigers had a bad time when they presented a broadside shot and were wounded between the ribs. But given an "end on" shot, or in the case where a mass of muscle was struck, as in the shoulder of a large tiger, no premanent injury was inflicted, and though the animal might be thrown off its balance, it generally arose in an extremely unaimable temper and made things lively for what seemed ages! The extreme haudiness and accuracy of this Express rifle counterbalanced in some degree the want of penetration, a drawback which was naturally not discovered for some time, as those animals which were only superficially wounded, were not brought to bag, and in consequence the effect of the bullet could not be determined. I shot with it with varying fortunes for some years; at times killing tigers with one bullet when hit in the soft, at others producing no effect, until I would no longer conceal from myself its palpable inferiority when attacking dangerous game single handed. In four weeks I lost as many tigers which were struck on the shoulder; on more than one occasion I found myself in extremely awkward positions, owing to the fact that tigers supposed to be dead were in reality extremely lively and angry; and finally, I had the opportunity of examining the course of a bullet fired at 20 feet distance which had struck a large tiger in the shoulder and had been reduced to powder without penetrating any vital part or even at the time seriously affecting the mobility of the heart. The result of this dissection was the registration of a vow that never again would I with a similar weapon attack dangerous game unless circumstances gave me a decided advantage in every way! The cause of this dangerous want of penetration was of course referable to a high velocity which broke up the hardened and brittle bullet on impact; and it may be asked why not use soft lead solid bullets in the rifle? The answer to this question is that by doing so the accuracy of the rifle was fatally impaired. In a delicate piece of mechanism like a first class rifle, accuracy is dependent on much more trifling details than the alteration of the weight of a bullet, and such a rifle, regulated to a nicety as to weight and length of projectile and powder charge, would turn out a most unreliable weapon if fired under other conditions than those attending its regulation. The result of the experience above set forth leads

me to the conclusion that hollow-fronted bullets confer no advantage by their use and that they are altogether a mistake. The rifle in which I would place confidence is one in which the weight of the powder charge is not less than one third of the weight of the bullet. The rifle should be regulated to fire a solid soft lead bullet which would give great penetration with a certain amount of expansion of the projectile; if no such expansion is required, the addition of a very small percentage of tin would result in even more penetration; whilst if less penetration and the complete breaking up of the bullet is desired, this can be obtained by increasing the hardness and therefore brittleness of the bullet, the consequent reduction in weight of the projectile increasing at the same time its initial velocity. The hardening of the bullet would of course result in reducing the weight but to so small an extent, that accuracy may be maintained by a minute reduction in the powder charge, which I have found an impossibility when a heavier bullet than that to which the rifle has been regulated is used. Would other sportsmen record their opinion and experience on these points in the *Forester*? We want not a record of the marvels which have been effected by hollow-fronted bullets travelling at high velocity, but rather details of cases in which the Express rifle used with such bullets has proved an unreliable weapon with which to face dangerous game.

O. C.

VI—EXTRACTS, NOTES AND QUERIES

The Coopers Hill Prize-day.

We extract from the *Pioneer* the following reference to Forestry by the late Secretary of State for India, Lord Cross. It is not of much importance! "No one who has looked into the matter can fail to regret that the establishment of a school of forestry in England should have been entirely neglected for so long. France and Germany have in this matter been far in advance of us, but now that we have got a considerable part of Windsor Forest in our own hands, I hope we shall be able to show the Office of Works that there are other people besides themselves who can manage trees, and that they may have something to learn from us."

The prize distribution took place on July 27th with the usual crowd of ex-Indian notabilities and the usual optimist speeches. We notice that none of the speakers mentioned the 1s. 2½d. rupee.

An examination of the Prize List shows that the following.

Forest Officers were winners.

Surveying—whole College	...	H. G. Billson, 2nd year.
Physics do.	...	Do.
Forest Management	...	C. O. Hanson, 2nd year.
Geology—whole College	...	B. O. Coventry, 1st year.
Chemical Laboratory do.	...	Do.
Botany	...	Do.
Sylviculture	...	Do.

There may be others, but we have no list of their names. The success of Messrs. Billson and Coventry is most creditable to them.

A serious Grievance.

We have received from a Junior Forest Officer in the Madras Presidency, a copy of a memorial which he has lately addressed to the Secretary of State. Our correspondent was one of the last batch that came out before the new Prospectus under which the Coopers Hill study time was raised to 3 years, and the pay of an officer on first joining was raised from Rs. 250 to Rs. 350. He now finds himself still in the 3rd grade of Assistants on Rs. 250 while men who have a year's less service are in the 2nd grade on Rs. 350. We drew special attention to the possibility of this grievance at page 124 of our March number, and we trust that the authorities will take the matter up and see justice done. We are of opinion that from the date of appointment of the first Rs. 350 man, all the then Rs. 250 men should have been promoted. How wide the grievance is we cannot tell in the long-continued absence of our old friend the green Departmental List whose re-appearance we trust will not be long delayed; but it clearly exists in Madras and possibly elsewhere.

Wattle Bark for Tanning.

The *Révue Agricole* of the Mauritius for April 1892, contains an interesting paper on the tanning industry of the colony of Victoria. Two species of *Acacia*, known as the "black wattle" (*A. decurrens*, Willd.) and the "golden wattle" (*A. pyrenantha*, Benth.) are the principal trees which yield tan; they are quick growers, and are easily cultivated. The "black wattle" especially, being very hardy, is useful as a nurse and for re-stocking barren places; it can be sown broadcast or in lines, and prefers sandy soils. At the age of five to seven years, it commences to yield tan of excellent quality. It is calculated that 100 acres of wattle plantation will give, in a period of eight

years, a net income, after deducting all expenses, of £2,637, or £3-5s per acre per annum. This may not seem much, but it must be remembered that this revenue is obtained from land where nothing else will grow. In the paper, it is strongly recommended for Algeria, and we see no reason why it should not be tried on a fairly large scale in India, certainly on the Nilgiris. The bark of these wattles contains from 40 to 45 per cent. of tannin.

A Tea-Estate pest in the Dun.

During the last two months the Dún has been visited by many insect pests. The most dangerous of these was the caterpillar of a moth which began by attacking the "Tallow tree" (*Sapium sebiferum*) and the Sissoo, so much planted on tea estates; and when it had cleared the leaves off these the caterpillars descended to the tea bushes and set to work on them also. Specimens of the caterpillar and moth were sent to the Indian Museum by the Director of the Forest School and the following is his reply on the subject.

"Your specimens belong to the group Noctues (Owlet moths), family Ophiuidæ. They are identical with moths in the Museum determined as *Achæa melicerte*, Drury, (of which there are several specimens in our collections). My identification of your specimens with the latter is, of course, subject to confirmation by Mr. Cotes on his return, but in my mind there is no doubt about the matter.

'I gather from Mr. Cotes's recent notes on the subject that *Achæa melicerte* is common in various parts of India, and it will take kindly to a variety of widely differing food-plants. For instance, it is reported as defoliating Castor-Oil (*Ricinus communis*) plants in Bengal, Assam, Madras, and Ceylon, attacking dhal (*Cajanus indicus*) plants in Dehra Dún; and Sugarcane (*Saccharum officinarum*), paddy (*Oryza sativa*) and brinjal (*Solanum Melongena*) plants in Ganjam.

'The caterpillar, which is sooty black with bright red, yellow and brown markings, must be a conspicuous object on the tea bushes, and could, I should say, be removed by hand-picking; possibly, however, the cost would be prohibitive. It has been suggested that by planting a few Castor-Oil plants (the favorite food plant of this moth) at intervals around the garden, the moth would be induced to lay her eggs on these instead of on the crop. In its crude form, I certainly cannot recommend a plan which would lessen the difficulties of existence, and as a natural consequence, increase the reproduction of the pest. But it is possible (and I think probable) that the pest would be concentrated on the Castor-Oil plants, where it would be more easily destroyed than if it were scattered over the

' garden ; and with this object I think a few Castor-Oil plants might be planted experimentally. It is recorded that in Madras the native "smoke" the Castor-Oil plants for this pest but the mode of procedure is not given. Mr. Cotes recommends spraying the plants by a force pump with a solution of "London purple." This is also in the case of its attack on Castor-Oil. I do not think London purple (which is an arsenical compound) could be safely used on tea bushes ; but, no doubt, on his return from leave, Mr. Cotes will be able to inform you on this and other points."

A Corner in "Nuns."

The devastation wrought among the trees in the Black Forest by the plague of insects known as "nuns" has caused considerable trouble and anxiety to the Woods and Forests department of the administration. The habits of the animal have for some years past been studied by naturalists with a view of devising some method for their extirpation ; but, until quite recently, every means adopted to this end failed of effect. Finally, an ingenious plan was hit upon whereby these pests were "swarmed" by the attraction of the electric light, and gathered in their millions in immense exhausting receivers, after which those which were thus caught were incontinently destroyed. It now, however, appears that Nature has herself come, in some mysterious way, to the aid of the authorities. A plague has broken out among the "nuns" themselves, of which they are found dying all over the forest. What may be the particular character of the disease which is destroying the destroyer is not known. The "nuns," however, collect in the hollows of the trees in great round heaps to die like brothers in affliction, and from this circumstance the local entomologists have given to the disease a name the nearest English translation of which is a "corner."—*Timber Trades Journal*.

State Forestry in America.

A Bill has been passed by the Legislature of New York to establish a great forest reserve or State park among the famous Adirondack Mountains. In signing the Bill, the Governor says :— " Out of 3,700,000 acres of land comprised in this region, the State now owns about 900,000 acres, half of which is situated in detached pieces, around the border of the wilderness. The intention of the Act is to enable the State to sell as much of this outside holding as may seem wise, and to buy in place of the lands thus sold more desirable timber lands near the heart of the forest and nearer the head waters of the great streams which

have their source in the Adirondacks, so that the end sought to be attained by the establishment of an Adirondack park may be more certainly accomplished. The advantage of this legislation is two-fold. In the first place, it is estimated that the State will be able to increase the acreage which it holds; secondly, the carrying out of the project contained in the Bill will consolidate the State's holdings and enable the State to pursue some rational and practical system of forestry, which is virtually impossible now. The scheme proposed by the Bill carries no appropriation with it, but all revenues from the sale of the so-called 'outside' lands will be devoted to the purchase of new lands better adapted for the purposes of a forest preserve. I have cheerfully approved the measure, for I believe thoroughly in the wisdom and actual necessity of preserving this great timbered wilderness for the protection of the headwaters of our streams, the commerce of the State, and for the benefit to agricultural interests which it yields in its important influence upon our rainfall."—*Weekly Times*.

The Brandis Prize.

In accordance with the conditions set forth in the notice on this subject in our Vol. XVI page 258 the following awards have been made.

1891.—Pandit Keshavanand for his 'Note on the germination of the Kharshu Oak'	Rs.	
	...	40
Babu Upendranath Kanjilal for his paper on the 'Bhalkua' bans'	...	30
1892.—T. C. Moss, for his paper on the 'Tinnevelly Forest'	...	50

VII.—TIMBER AND PRODUCTS TRADE.

Churchill and Sim's Circular,

September 5th, 1892.

EAST INDIA TEAK.—No improvement can be reported in the rate of consumption, which reflects with unpleasant fidelity the stagnation in the shipbuilding trade. The deliveries from the Docks have been 6,995 loads for the first eight months of this year against 9,841 loads and 10,836 loads for the same periods of 1891 and 1890 respectively. For August, the figures are 574 loads this year, 863 loads in 1891, and 1,801 loads

in 1890. Fortunately, there is no pressure of arrivals, and the stock being very moderate, quotations are well maintained for the small quantities passing into use.

ROSEWOOD.—EAST INDIA.—The demand remains very quiet and sales slow, the tendency of prices being rather easier.

SATINWOOD.—EAST INDIA—*Logs* unless large and *figury* are difficult to sell, but the stock is small: *planks* and *boards* are not wanted.

EBONY.—INDIA—The demand remains dull and stocks are heavy.

WALNUT.—MALABAR.—One log sold (we wish some of our readers would tell us what this wood is !)

MAHOGANY.—MALABAR.—Has sold rather more freely but prices remain low, specially when sales are forced. (What can this wood be ?)

Price Current.

Indian Teak	per load	£9 10s	to	£15
Cedar, Malabar,	per sup. ft.	3d	to	3½d
Satinwood	per ton	£6	to	£10
Rosewood	per ton	£7	to	£10
Ebony	per ton	£6	to	£9

MARKET RATES FOR PRODUCTS.

(*Tropical Agriculturist, September, 1892.*)

Cutch	per cwt.	24s.	to	34s.
Croton seeds	"	15s.	to	20s.
Gum Arabic, Madras	"	40s.	to	80s.
Gum Kino	"	75s.	to	80s.
India Rubber, Assam	per lb.	1s. 6d.	to	2s. 2d.
" Rangoon	"	1s. 7d.	to	1s. 10d.
Myrabolams, Bombay	per cwt.	9s.	to	10s. 6d.
" Jubbulpore	"	8s. 3d.	to	9s. 6d.
" Godavari	"	8s. 3d.	to	9s. 6d.
Nux Vomica, good	"	8s.	to	9s. 6d.
Orchella, Ceylon	"	20s.	to	25s.
Redwood, fair and fine bold,	per ton	£3.	to	£3-10s.
Sandal wood, logs	"	£35	to	£60
" chips	"	£9	to	£30
Sapanwood	"	£4	to	£7
Tamarinds	per cwt	8s.	to	10s.

THE
INDIAN FORESTER ;
A MONTHLY MAGAZINE
OF
FORESTRY,
AGRICULTURE, SHIKAR & TRAVEL.

EDITED BY

J. S. GAMBLE, M.A., F. L. S.,

CONSERVATOR OF FORESTS, AND DIRECTOR OF THE
FOREST SCHOOL, DEHRA DUN.

NOVEMBER, 1892.

MUSSOORIE :

PRINTED BY THE MAFASILITE PRINTING WORKS
COMPANY, " LIMITED."

1892.

Contents.

No. 11—NOVEMBER, 1892.

	Page.
I.—ORIGINAL ARTICLES AND TRANSLATIONS.—	
<i>The Andamans</i> by E. M. B.	411
<i>The condition of Forestry in New Zealand</i>	416
<i>Tour of the Coopers Hill students in France</i> (Translation)	417
<i>A great day at the Forest School at Nancy</i>	417
<i>Grazing and commutation in the Central Pro-</i> <i>vinces</i>	418
II.—CORRESPONDENCE.—	
<i>Forest and other Civil Officers in Bombay, by</i> <i>“Professional Operator”</i>	419
<i>The Bombay Administrative Rules</i>	423
III.—OFFICIAL PAPERS AND INTELLIGENCE.	
<i>Forest Fellows of Coopers Hill</i>	424
<i>Joining arrangements for Forest Officers on first</i> <i>arrival</i>	424
<i>The re-organization of the Provincial and sub-</i> <i>ordinate services</i>	425
IV.—REVIEWS.	
<i>Report on the operations of the Department of</i> <i>Land Records and Agriculture, Madras, for</i> <i>1890-91.</i>	434
<i>Administration Report of the Railways in India</i> <i>for 1891-92.</i>	435
<i>Forestry in South Australia</i>	436
V.—SHIKAR.—	
<i>A trip to Bara Bangahal</i> by F. O. L. No. 2	437
<i>Forest School Sports, Dehra Dún</i>	441
VI.—EXTRACTS, NOTES AND QUERIES.—	
<i>On Judicious Pruning</i>	443
<i>The history of a Railway Sleeper</i>	446
VII.—TIMBER AND PRODUCE SALES.—	
<i>Churchill and Sin's Circular, September 5th, 1892.</i>	449
<i>Market rates for Products</i>	450
VIII.—EXTRACTS FROM OFFICIAL GAZETTES.	

SUPPLEMENT.

APPENDIX SERIES OF THE INDIAN FORESTER.

Indian Woods for Tea Boxes.

(To be substituted for ERRATA slip of October Number.)

ERRATA,

JULY, 1892.

- Page 258, line 19, for 'except to proven' read 'except to approved'
Page 262, last line but three, for 'advertising it' read 'advertising ordinary trade turpentine'
Do. ,, last line but one, for 'new' read 'now.'

AUGUST, 1892.

- Page 285, line 2, for 'W. Buurman, Forester,' read 'W. Buurman, Inspector-General of Forests in Netherlands India.'
,, 298, ,, 25, for 'Hotgat' read 'Hatgat'
,, ,, 33, for 'Atlur' read 'Attur'
,, ,, 35, for 'India' read 'Nidta'
,, ,, 40, for 'Kirajpet' read 'Virajpet'
Page 302 ,, 24, before 'in appearance'
add ,, 'Now we come to the Nandi, and though there seems to be an undefined idea that'
line 28, for 'Mattis' read 'Nandis'
Page 323, line 19, for HERZEGOVIAN' read 'HERZEGOVINA'
,, 327, last line, but one, for 'radish' read 'reddish'
last line for 'Sissue' read 'Sissu,' and before it insert 'or.'

We regret that we should have made the mistake as to the rank of Herr Buurman. In the original Dutch the word was 'Houtvester' which really corresponds to 'Conservator of Forests.' It was translated 'Forester' and as in some of our colonies 'Forester' and similar terms are often used, we believe, for officers of some rank, we did not notice the mistake. Herr Buurman is now Inspector General of Forests in Java and Madura.

OCTOBER, 1892.

- Page 376, line 25, for ',Garuga, pinnata' read 'Garuga pinnata'
,, 381, ,, 21, for 'contral' read 'control'
,, 408, ,, 26, for 'T. C. Moss' read 'S. C. Moss.'

HON. ED.

1871

THE
INDIAN FORESTER.

Vol. XVIII.]

November, 1892.

[No 11.

The Andamans.

A few years ago the Andamans were spoken of vaguely as a group of small islands somewhere in the Bay of Bengal, on one of which there was a penal Settlement called Port Blair, to which the Indian Government found it convenient to transport its least promising subjects. Of late years, however, the Settlement has become better known. The Asiatic Steam Navigation Company have made their "round" run between Calcutta, Port Blair, Rangoon and Madras, a popular one, with numbers of people who like a breath of sea air, or who need it. So that Port Blair has begun to have plenty of visitors, who make the usual inspection of the Settlement, interview the curious little Andamanese, and then go away to tell their friends in India 'ALL' about the Andamans. But one of the chief causes of the growing importance of the Andamans they seldom discovered. This is the establishment of a flourishing trade in Padauk Timber (*Pterocarpus indicus*) by the Forest Department. The rapidly increasing export of timber (now including other species besides Padauk) from these islands, must give them a high place amongst timber-producing countries in the near future; so foresters in India and Burma may like to have a sketch of the forests, and of the Settlement generally.

Although, hitherto, the Andamans have been, as a Forest Division, administered by the Government of India, for the sake of convenience, they naturally belong to Burma. Geologists say that the Aracan Yoma (N. B. "Yoma" is the Burmese for spine, and when applied to natural features of the earth's surface means a hill range, the spurs being considered as ribs) once ran as far as south latitude $10^{\circ}30'$ ——, but in company with the continent which is supposed to have subsided here long ago, a great part of the Yoma went under the sea, leaving only a few of the highest peaks above water in the form of islands. The position of the Andamans, and the fact of the soil formation being absolutely the same as that of the Aracan hills, seems to prove this theory

completely. The islands so left, form one of the prettiest groups in the Indian Ocean. To climb a hill and gaze on the confusion of forest clad spurs dipping into the blue sea, fills one with a sense of mingled wonder and pleasure. Looking closer, the scenery affords some variety in the winding inlets of the sea which lead to the mouths of tidal creeks, flowing through dense forests of mangrove, from the valleys farther inland.

THE FORESTS.

The Mangrove swamps are like such swamps elsewhere, except that the trees seem to be of better growth, and the presence of palms (*Calamus*, *Wallichia*, *Areca*, &c.), Screw Pines (*Pandanus*) and occasionally *Mimusops littoralis*, on the inner fringes of the Mangrove, causes in part the tendency to sameness in the scenery. The rising ground from the edge of the swamps up to the highest ridges, is covered densely with high forest. Gurjan (*Dipterocarpus tuberculatus*) and *D. alatus*) Burmese "Kanyiu" are the best represented species of tree. The immense white stems of these trees tower over the rest of the forest, often reaching the height of 150 feet or more. A step lower than the tops of the Gurjan giants, but still quite a hundred feet from the ground, is the general canopy, formed by the crowns of such species as Padauk, pyinma (*Lagerstroemia hypoleuca*), *Artocarpus Lakoocha*, *Croton argyratus*, *Amoora*, *Baccaurea sapida* (Burmese Kanaso'), *Myristica Irya*, *Hopea odorata*, *Mesua ferrea*, *Albizia Lebbek*, *Murraya exotica*, and *Podocarpus bracteata*, the four last being found more inland. *Casuarinas* grow in fringes on the sandy parts of the coast. Bamboos are not common. There are only two kinds, one being a relation of the Burmese 'Wathabwot' a straggling climber slightly ornamental but of no use. The other is probably *Bambusa schizostachyoides*. The culms are straight and spineless, but small and very hollow. The clumps are graceful; and when planted along the sides of roads this bamboo makes very pretty avenues.

The character of the forest seems to have originally been the same as that of some of the commoner types of forest in Burma (particularly those on the lower hills of Tenasserim). But changes have taken place since the isolation of the Andamans and in spite of the large number of trees like Padauk, pyinma, gurjan, gangaw (*mesna ferrea*) and others which are common to both Burma and the Andamans, the absence of some Burmese species and the presence of others which have not their equivalent in Burma, give rise to much doubt concerning the relations originally existing between the forests of the islands and those of the main land

A marked feature of the forests of the Andamans is the compactness of the canopy everywhere. Only the most shade-enduring species are able to reproduce themselves. Padauk (the

principal timber tree) and other light loving species are fast dying out, as the seedlings invariably succumb after struggling for a year or two in the gloom. Only very old trees of Padauk are to be found, excepting a few young trees which have lately grown up on the sides of road or other artificial clearings. Whether Padauk originally grew all over the islands or not, it is now confined to certain soils, and within certain limits which are probably determined by elevation and aspect, but this is not certain. The Dipterocarpeæ and many others of the characteristic species grow everywhere, whatever the soil or aspect may be.

Forest glades do not exist, and this is one explanation of the fact that there are no wild animals in the islands, excepting pigs, and a species of wild cat (*Paradoxurus Andamanicus*.) This is a case in the struggle for existence, where vegetable has gained the mastery over animal life. Iguanas, lizards and snakes are common. Forest birds, especially parrots and kingfishers, abound. Game birds are rare and belong to migratory kinds such as teal and snipe. The Andamanese, who have survived with the cats and pigs, have made no more impression on the forests than the latter, as they appear to have never had any idea of cultivating the soil, and so have never made any clearings. They are an interesting people, notwithstanding their primitiveness, and if their story is likely to please, it can easily be told some other time.

Such a green country, situated in the middle of the sea, must necessarily have a moist climate. Old residents say that the rainy season in the Andamans lasts from May to December. This proves to be the case, only the chances are that the season, from accidental atmospheric changes, sets in a month early and lingers on for a month longer than it is expected to.

Under these conditions, it is useless to try and distinguish between the wet and dry seasons with respect to choosing a suitable time for outdoor work. Felling and extracting of timber, loading of ships, and general inspection is equally agreeable at all times of the year, so work is carried on continuously. Over six hundred convicts and 24 elephants are engaged in the forests to bring timber to the forest depôts, from which the timber is exported, to some extent by cart, but mostly by a very successful tramway, to the various sale depôts on the water. Most of the woods named above are taken up largely for local works by the Settlement Officers, excepting Padauk which is used sparingly in the Settlement and is reserved for export to India, to Burma, and chiefly to London. Of late years, nearly 200 tons of Padauk timber have been disposed of annually in London with considerable profit. The demand is growing, as the timber is finding American buyers, and might be developed indefinitely if the resources of the Andamans permitted a larger export, but it is not certain yet whether the forests can safely be made to yield more than 2,000 tons a year besides the 400 or

500 tons that go to India and Burma. Dark-colored wood is always sent to London as it is used for cabinet work ; the light-colored Padauk is disposed of in India, where color is no object, but the aim of the purchaser is to get strong solid timber for making gun carriages, or railway cars. Besides coloured Padauk, the Andamans forests produce other good fancy woods, the best known of which are marble wood (*Diospyros Kurzii*), and Satin-wood (*Murraya exotica*.)

The following table will give an idea of the revenue made by the Department. Besides this, and a small profit made by the sale of tea from the local tea plantations, the Local Government gets no appreciable revenue.

	Receipts.	Expendi- ture.	Net.	
1889-90	162,195	94,975	67,220	
1890-91	158,325	130,052	28,273	
1891-92	272,338	179,908	92,430	
1892-93	303,000	209,000	94,000	Estimate.
			70,481	Average.

The peculiarity (noted above) of the Padauk not being able to hold its own against more shade-enduring species, makes it imperative to help the former by the usual artificial means. So the Forest Department does its best by clearing around seed bearers, in the forest to be worked over, and by planting largely over areas that have been exploited, to ensure the reproduction of Padauk ; while similar measures are to be adopted, when practicable, for other valuable species which need protection from their neighbours.

A plantation of Padauk was started in 1883 and new plantations or extensions have been made regularly ever since then except in 1888. The system at first was to make large clearings and plant these up with Padauk, or with Padauk and teak in alternate lines. But a better method was soon adopted for Padauk, that is, planting in lines 20 feet wide cleared through the forest. This method is to be followed in future in planting teak also, or any other species.

The Padauk plantations have always been successful. A few words about teak, which has been planted for the sake of experiment, will be interesting. Mr. Ferrars started planting teak in 1883, and his experiments were continued by Mr. Carter. Planting over areas clean felled, and also in lines through the

forest was tried with more or less success. The plantations in the clearings are the best at the present time, but this is most likely due to the saplings in the lines having been crowded by weeds and so kept back. In future, it is intended to plant teak in alternate lines with Padauk, through the forest. The lines are to be 5 or 20 feet wide, and 100 feet apart, and the area to be planted over to be as nearly as possible half a square mile.

The teak in the oldest plantations, which are situated in an open valley (Gopalakabang) about 6 miles from the sea, is as well grown as that in most plantations in Burma. Trees ten years old are beginning to pass out of the small pole stage already. They are straight and of good girth. The only noticeable feature in their growth is a tendency for the bark to get dry and hard in the hot weather and so to retard expansion. But this will probably not occur when planting is done in the forest and some shelter secured from the sun by the presence of evergreen trees between the lines.

The late cyclone thinned the older parts of the Gopalakabang plantations severely. The injured boles are being coppiced with very good results however. In the younger parts of the plantation the saplings escaped injury. There are several irregular plantations of teak in the station more or less full of well grown young trees, and there is a broken line of teak on one side of the harbour which is within reach of the spray of the sea in rough weather. The progress of the latter will be very interesting to note. Before concluding the remarks on plantations it may be noted that the Dhani palm (*Nipa fruticans*) has been successfully introduced into some of the tidal creeks by the Department affording a great deal of the thatch used for roofing temporary buildings.

As a residence, Port Blair is considered, at least by those who are obliged to stay here, as a very pleasant little place. Visitors pretend to find some drawbacks to life in the Settlement, but then they have not had time to form a correct opinion on the subject.

There is not hot weather, as it is understood in India. But there is no cold weather. The climate is lukewarm, and though healthy it is very enervating. People get on from day to day in a sleepy way which is very pleasant after the restless turmoil of busier places. But they wake up occasionally when the mail Steamer comes in, or when a man-of-war or a general inspecting officer visits the Settlement; and then for a few days, a surprising amount of business, as well as gaiety, is got through. In addition to the usual amusements, those who are inclined that way might try their skill at the slightly risky, but very enjoyable pastime of sailing.

Port Blair has no fruits, no pretty meadow flowers, or vegetables to induce people to garden; and so, unfortunately, there are none of those pretty cool retreats which are such a

pleasant feature in most Indian stations, but there are instead open grassy downs diversified by hedges of *Vitex* and *Agave*, *Croton* and *Hibiscus*, and groves of lofty *Casuarinas*. The rich and varied profusion of the *Crotons* and *Shoe flowers* gives exceedingly lively, but pretty, coloring to the scenery, and a ride across country affords at least as much pleasure as a drive through almost any garden in India. There are two favourite holiday resorts close to the station,—*Corbyn's Cave* on the east coast, and *Mount Harriet* a hill just over a thousand feet high on which the Government has very considerably built and furnished a *Rest House* for the benefit of over-worked officers and invalids.

E. M. B.

The condition of Forestry in New Zealand.

The following extract from the letter of a correspondent of the *Pioneer* will be interesting to our readers as shewing the present state of things in New Zealand in respect to Forest Conservancy. We suppose that as soon as all the natural forests have been destroyed, the next turn of the wheel will once more bring Forestry to the front with extensive planting works and heavy expenditure to retrieve what ought never to have been lost. It will be a thousand pities if every remnant of the magnificent *Kauri Forests* is swept away in the anxiety for new sheep lands.

“ There was a lovely view of the hills through which the beautiful *Manawatee Gorge* winds, the entrance to which was just in front of us. These hills are covered with dense bush, which has been selected as a forest reserve by Government but —alas!—since then I hear it has been unable to resist the pressure brought to bear on it by a people hungry for land, and this belt of forest which in a few years, when the settler has stripped all the country round of timber, and burnt it to lay down the land in grass, would have been of great value, is deemed to axe and fire. Several men whose views should carry weight, have told me that, in their opinion, good bush land, fairly situated as regards communications, would, if retained as forest for the sake of the timber, give a better return by the end of 20 years than if it had been grassed and fed with sheep or cattle. At present timber is looked on in the light of a noxious product of the soil, to be destroyed as rapidly and effectually as possible, but the time must come when it will have a considerable commercial value. Sometime back, Government had men as ministers far seeing enough to recognise this, and forest reserves were created, to save a certain amount of timber, but the working-man, who cannot see beyond the length of his nose, is now Lord Paramount of New Zealand, and he cares for nothing beyond the immediate present.”

Tour of the Coopers Hill Students in France.

Last year the students of the English Forest School under the able direction of Dr. Schlich and Mr. Fisher, one of our first foreign comrades at the "Ecole" at Nancy, came to visit the splendid high forests of the Forêt de Lyons. Encouraged by his first visit, Mr. Fisher wished this year not only to show his students the dense crops which make the forest of Lyons an unrivalled beech forest, but also to study in detail the organization of the Working Circle and the application of the Working Plan during the last few years. A thorough and careful teaching had well prepared these young men for appreciating the treatment as well as the beauty of the crop they inspected during the course of the week they spent there.

The forest officers of Lyons have been pleased to serve as guides to such intelligent students and they were proud to find again in them French forest traditions become international. They are confident that this visit will leave with their guests the pleasant remembrances that they themselves have kept of it, and will help to draw closer those bonds of brotherhood formed now long ago under the influence of the hospitality of Nancy.

The English School went on afterwards to see the forests of the Perche which had also been visited in the previous year. From the 21st to the 25th of July, twelve of the senior of the students under the guidance of the amiable Professor of sylviculture, Mr. Fisher, studied the magnificent high forests of oak of Bellême, Perche-la-Trappe and Réno-Valdien, the local forest officers rendering them ready and willing assistance.

The forest of Bellême is the classical land of the oak as the forest of Lyons is that of the beech.—(*Révue des Eaux et Forêts Translation*).

A great day at the Forest School at Nancy.

On the 6th of June last, the Forest School at Nancy was visited by the President of the French Republic who had gone to Nancy for the fêtes of the 18th Congress of the Gymnastic Societies. The visit to the School did not form part of the original programme and it was only within a day or two of his arrival that M. Puton, the Director, was made aware of the intention of the President to spend a short time at the School, this change in his plans having been brought about by the intervention of the deputies and senators of the Department. Professors and students at once set to work to prepare for his reception, and though the time at their disposal was short, the result appears to have been very satisfactory.

An enormous arch of triumph was constructed under the direction of Messrs. Thiéry and Petitcollot, out of two large Silver Fir trunks, broken across the middle, covered with mosses, flags and inscriptions, decorated with the heads of wild animals, &c. and erected in the Rue de la Constitution. The Rue Girardet was also decorated for the occasion.

Messrs. Puton, Lamblé, and Boppe, received the President and suite at the outer gate of the School: and, after the usual presentations, the President was conducted to the great courtyard where M. Puton delivered a short address expressing his satisfaction at the mark of attention thus shown to the Forest Department and referring to various points in which the Republic had shown itself more favourable than any other form of Government, to forest interests. After Mr. Carnot's reply to this address, the students marched past under the command of Lt.-Colonel Montignault. Then other parts of the School, the museum &c. were visited, and the President was finally escorted to his carriage, the students being drawn up in two files to salute him on his departure. It is not often that the Forest School has the honor of receiving the Chief of the State. Let us hope that the ceremony will add to the already great prestige of the Department so ably managed by our French comrades of the Nancy Institution.

Grazing and Commutation in the C. P.

The supplement to the C. P. Gazette of the 6th of August last, contains a Resolution by the Chief Commissioner on certain questions which were laid before the Forest Committee, which sat in Pachmarhi in April, 1891. In this Resolution, the Chief Commissioner orders the tentative adoption of commutation as applied to the pasturing of cattle in lieu of the old system under which we believe that each individual took out a license for the number of cattle he wished to pasture. In future, the Mukaddam of the village will submit a statement of the grazing requirements of the village and a consolidated license will be issued for that village, the Mukaddam collecting the necessary fees. Provisionally, the commuted payment will be reduced 10% under the aggregate which the payments for the village would reach if each individual had to take out a license separately.

A further concession has also been made in favour of those owners of cattle wishing to graze in districts other than that in which they reside by authorizing the issue to such of a nomad license such as has hitherto, it appears, been reserved for Banjaras, Beparis and other similar nomadic owners of cattle, the rates for such licenses being a little in excess of the ordinary district rates.

It appears that the substitution of a system of annual commutation for other forest produce as well as grazing, instead of the present license system, was proposed, but the Chief Commissioner, we are glad to see, has rejected this proposal which would surely have been a step backwards instead of one of progress.

We are inclined to think that the remedy for, at any rate, some proportion of the difficulties in connection with Nistar, might be sought elsewhere than in the Government Forest Rates; The abuse of Malguzari Forest Lands is a matter which has however also received the attention of the Chief Commissioner, and should the Rules in respect of these be carefully carried out, they should in time, where such lands exist, help to alleviate some of the troubles complained of by the cultivators.

A currency of one week for all licenses for the extraction of forest produce has for the present been prescribed, which as the Subordinate Forest Staff is to be increased, may not lead to so much loss as it otherwise would in those cases where the removers of produce live near the Forests and the Forest Guard's beat is too large to allow of his checking all the produce removed; as it will be a great temptation to removers who have conveyed their produce from the forest without check to return again and again so long as they are provided with a pass that is still valid.

II.-CORRESPONDENCE.

Forest and other Civil Officers in Bombay and elsewhere.

SIR,

The article on Forest and Revenue Officers in the October number of the "Indian Forester" appeared opportunely with the reprint of Bombay G. O. No. 7107 dated 6th September, 1892, in that number; your readers have thus the opportunity of learning how matters are to be managed in the west of the peninsula, how they are managed in other parts of India and on what general basis the relations between Forest and Revenue Officers should, in your opinion, stand.

The principles adopted by other Governments than that of Bombay are briefly that the Chief District Officer is responsible

for the management of the forests in his district, the Divisional Forest officer being his Assistant in Executive matters; that the entire control of finance and establishment rests with the Conservator who further addresses all recommendations for the working of the forest, through the Revenue officers for an expression of opinion, direct to the Local Government; in short, that the District Forest officer should not be exposed to interference from the departments but "under the Collector's orders and supervision carry out the instructions of the Conservator."

The regulations issued on this subject by different Governments must of course vary in detail, but they agree in maintaining the authority of the Conservator, in permitting a proper amount of patronage, of making him the representative of Forest interests, and enabling him to present his opinion and advice on forest matters to the Local Government, whilst they lay the responsibility of the finance of the Circle entirely on the chief forest officer. These principles are sound and have stood the test of many years working, for by these means the interest of the District Officer in his forests is aroused, the position of the Divisional Officer is strengthened, and the Local Governments are in the best position for deciding any questions of administration when placed in possession of the views of the Forest and Revenue officers concerned.

Let us now consider the principles adopted and the regulations issued by the Government of Bombay in the above quoted Notification. These rules, 28 in number, profess to be for the purpose of prescribing and limiting the powers and duties of Forest Officers under Act VII of 1878, but would appear to an outsider designed rather to limit the powers of the Forest Officer and prescribe the duties of other Civil Officers. A careful search fails to show that the Forest Officer is empowered to do anything but carry out the orders of the Collector; whilst a Conservator may not refer to Government save in questions of finance and establishment or in the case where he disagrees with a Collector. The regulations may conveniently be divided under three heads: I, paras 1 to 16, treating of the duties and position of Forest Officers; II, paras 17 to 27, treating of the duties of other Civil Officers; and III, the final para, in which the duties and position of Commissioners of Civil Divisions are prescribed. Head I opens with the declaration that Forest Administration is a branch of Land Revenue Administration, and proceeds to place the management of the State Forest in the hands of the Collector, the Conservator only retaining the direction of "professional operations of technical forestry" and subject to the sanction of the Local Government, departmental finance and control of Forest Officers. Paras 6 and 7 place the entire control and patronage of the Subordinate Establishment in the hands of the Collector; 8 and 9 remove the question of local supply of produce and of rights and privileges not only from the

control but from the cognizance of the Forest Officer; 10 and 11 regulate correspondence between Conservators and Forest and District Officers and provide for the revision by the Collector of the Conservator's orders to his subordinates; whilst 11 to 16 empowers the Collector to deal with yearly plans of operations, but only obliges him to forward to the Conservator copies of such plans as may have met with his approval.

Under head II, paras 17 to 20 regulate the inspection of Range Offices by Revenue Officers and the procedure to be adopted in correspondence by Forest Officers; paras 21 to 22 detail the method to be adopted in exploiting compartments; and the following five rules prescribe the powers of Head Constables and other Civil Officers in the inspection of forests. Head III, the final para, gives unlimited power to Commissioners who may interpret Government Orders, settle all departmental differences of opinion, and refer to Government or decide as they think fit on reports on forest matters submitted to them.

The first thing that strikes the reader of these rules is that the Conservator, except in the direction of "professional operations of technical forestry" (one feels that that phrase cannot be too often repeated) or in questions of departmental finance has no voice whatever in the local management of his forests: he is indeed invested with the Departmental Control of Forest Officers, but as he can appoint or post no one, and can issue no orders without the approval of the Collector, this part of his duties would not interfere with his leisure; while, as to the working of the forests of his Circle, he can read the plans of operations approved of by the Collector and leave that official to carry them out. A further study of the rules inclines the reader to the opinion that not only is there no need for Conservators, but also that Divisional Forest Officers are not a necessity in the forests under the Government of Bombay. The Collector arranges all forest matters, sometimes with and sometimes without the knowledge of his district forest officers, who moreover may not correspond directly with their superior officer. The inspection of Range Offices is carried out by subordinate revenue officials, whilst Foresters and Forest Guards may be officially inspected by all and sundry, from a constable upwards. It appears almost superfluous to retain a special forest officer to add to the pile of information collected by subordinates of other departments who presumably forward their reports through their immediate superiors to the Collector.

It is presumable, from rules 9 and 21, that all the forests of the Bombay Presidency are not yet under the prescription of duly sanctioned Working Plans, so that a small number of forest officers have still some reason for existence under that Government. In any case, the provisions of rule 22 will no doubt act as a spur to Conservators in the matter of keeping their fellings up to date, for any delay in carrying out these

'professional operations of technical forestry' may be speedily avenged by converting them into amateur operations of self-interested destruction! It seems somewhat severe that *necessary* delay in felling operations should by any possibility result in the sudden withdrawal, at the expense of the forest, of scientific management!

It must, of course, always be, in the absence of local knowledge, difficult to criticise forest regulations, but the position of forest officers in Bombay would appear to be so very peculiar, and the work exacted and responsibility imposed under these new rules so very insignificant, that the following suggestions are made and may be taken for what they are worth.

- i.—That from the date of the issue of G. O. No. 71 all Bombay Forest Officers should be retired on full pension with the exception of a few officers specially selected to form a new Forest Department.
- ii.—That this new Forest Department shall consist of a chief forest officer with a suitable staff under his exclusive control whose duties would be confined to the compilation of Working Plans and to the direction of "professional operations of technical forestry."
- iii.—That the entire management of the State forests should be vested in all revenue and police officers of and above the rank of Head Constable under the immediate supervision of the Collector, who would be personally responsible that the terms of Working Plans were strictly carried out.
- iv.—That no Collector should be permitted to assume charge of a district until he had passed a searching examination into his knowledge of Forest Law, the utility of Forests and the Principles of silviculture. In this Examination the private opinions of the examinee should not be accepted if at variance with acknowledged authorities on the subject.

The above suggestions may appear to be dictated rather by humour than by common sense, but to this it may be replied that the existing regulations appear to be influenced by neither the one nor the other! At any rate, the proposals made would be acceptable to most Bombay forest officers, whilst the working would be followed with interest from happier Provinces by many a

"PROFESSIONAL OPERATOR."

The Bombay Administrative Rules.

SIR,

In the "Extracts from Official Gazettes," appended to your October issue, appears an order (No. 7,107 dated the 6th September 1892) of the Government of Bombay prescribing and limiting the powers and duties of Forest Officers in that Presidency under the Forest Act. The rules purport to have been issued under Section 75 (a) of Act VII of 1878; and breaches of the regulations are, it is inferred, punishable under Section 76, which allows of imprisonment for one month, or a fine not exceeding Rs. 500, or both. Accordingly, if, for example, the Collector does not from time to time inspect all the Range Offices of his District; or if Compartments of a Forest block are not felled in regular rotation; or if the Local Forest Officer does not inform the Collector of places where cuttings are to be made; or if a Police Officer does not, on examining a Forest Guard's diary, write the word "seen" with his initials after the last entry, or calls a guard off his beat; or if the Forest Officer fails to submit to his Collector between the 30th June and 15th July, the Plan of Operations, then shall the culpable parties be criminally prosecuted and punished. The Legislature, in its wisdom, has mercifully abstained from providing that in offences of this nature double penalties may be inflicted when the offence is committed at night or after preparation for resistance to authority; or even when a previous conviction for a like offence has been obtained. But the prospect is sufficiently serious as it is, and the only crumb of comfort for the apprehensive Collector or Forest Officer is that Commissioners themselves are liable to incarceration or fine or both, for breaches of Rule 28. The Bombay Government, true to its motto, has been the first to give effect to Section 75 in this manner, but it may be hoped that its example will not be rashly followed by other Administrations!

It will probably be found that the Rules have no legal sanction whatsoever. Except in the preamble (which itself curiously misrepresents the scope of the orders) no section of the Forest Act is mentioned. The Rules do not appear to be Rules under the Act at all, but Administrative Orders of the Local Government, and should have been issued merely as such. The blunder, if blunder it be, is probably unique in the annals of the Forest Administration in India.

PUNJABI.

68

III.—OFFICIAL PAPERS & INTELLIGENCE.

Forest Fellows of Coopers Hill.

In re-printing the following order of the Secretary of State regarding the admission of Forest Officers who pass out of Coopers Hill as to eligibility for the Fellowship, we wish to express the hope that the authorities will not merely put it in force for the future, but will also admit to the benefits of the new rule such of those who have already passed out as they consider would have earned the distinction, had the Rules been in force in their time.

"I am directed by the Secretary of State for India in Council to acknowledge the receipt of your letter, dated the 7th July, proposing that a small number of distinguished Forest students should be annually appointed "Fellows of Coopers Hill," in the same way as Engineer students are now appointed under orders passed by the Marquis of Salisbury in 1877.

2. In reply, I am to state that Viscount Cross sanctions your proposal, on the ground that the distinction of "Fellow" will be an additional incentive to diligence and proficiency on the part of the Forest students. The selection for Fellowships should be made by the President in consultation with the Principal Professor of Forestry, and not more than two students should be selected in any year.

3. A copy of your letter and of this reply will be forwarded to the Government of India, in order that the title of "Fellow of Coopers Hill" may be attached to the names of Forest Officers gaining the distinction in the official lists, as is already done in the case of Engineer Officers who have gained Fellowships.

Joining arrangements for Forest Officers on first arrival.

It has been brought to the notice of the Government of India that, in consequence of orders not awaiting them, on arrival from England, as to the stations to which they should proceed for duty, professionally-trained Forest Officers appointed by Her Majesty's Secretary of State occasionally get two periods of joining-time—i. e. from place of disembarkation to provincial headquarters and from headquarters to ultimate destination—before they actually enter upon their duties. To prevent, as far as

possible, the recurrence of this unnecessary waste of time, I am directed to say that in future, as soon as intimation is received by the Government of India from the India Office of the dates of departure from England (with names of vessels), and of the ports of landing in India, of the officers posted to the different provinces, the requisite particulars will be communicated, by telegram from this Department, to the Local Governments and Administrations concerned. The latter should thereupon arrange to let the officers expected know, immediately on arrival at the place of disembarkation, the stations to which they have individually been posted and to which they should proceed direct, together with such instructions or information as may be necessary in connection with the journey to such stations.

2. No officers will arrive in India from England this year for the Indian Forest Service, and the arrangements indicated in the foregoing paragraph will therefore, come into force next year.

The Reorganization of the Provincial and Subordinate Services.

Extracts from a Note by the Inspector General of Forests on the reorganization of the Provincial and Subordinate Forest Services, dated 3rd June 1892.

This note deals with the proposed reorganization of the Provincial and Subordinate Forest Services, in so far as this has not already been dealt with by the creation of appointments in the class of Extra-Assistant Conservators, which necessitated the Secretary of State's sanction.

My proposals regarding the reorganization of the Forest Department in India have to a certain extent been based on the present organization of the forest administration in the Prussian monarchy, which had been remodelled on the lines of the French administration, and in close connection with improved means of communication and postal and telegraphic progress.

Under these circumstances, I may perhaps be permitted to sketch briefly the present Prussian organization.

A.—Imperial Administration.—At the head of the forest administration stands the "Oberlandforstmeister." He is a Joint-Secretary to Government (Director of a ministerial branch), and is directly subordinate to the Minister for Agriculture, Settlements, State-domains and Forests in all technical questions and those relating to the forest staff. In questions affecting the agricultural population the cases may be referred to the Minister

by the Secretary in the Department of Revenue and Agriculture (if verbally, as a rule, in the presence of the "Oberlandforstmeister.")

The Director is assisted by a Board consisting of four ordinary members and two deputy-members.

The ordinary members are technically-trained forest officers, and are called, "Landforstmeister" or "Oberforstmeister," according to seniority; they are Under Secretaries in the ministry. The first deputy-member is in special charge of forest settlements and commutation of rights, on account of which latter, an annual minimum expenditure of 2,000,000 marks is provided in each year's budget. He must be either a lawyer by profession, or a forest officer who has passed the examination of an advocate in the Chief Court. The second deputy-member is in charge of working-plans, and must have passed a special examination in surveys and working-plans, in addition to the general examination in these subjects which is demanded from all officers in the superior service. He has got a separate office, the members of which are selected from among young working-plans officers and surveyors.

The deputy-members rank as "Oberforstmeister" and "Forstmeister," as the case may be. The Director deals direct with all general questions affecting the whole monarchy and with all personal questions, and has the direction of the Board.

The work of the ordinary members is arranged according to groups of provinces.

B.—Provincial Administration.—The officer in charge of the forest administration of a province or circle is called "Oberforstmeister," corresponding to our Conservators. The chief "Oberforstmeister" in a province is Deputy-Secretary to the Provincial Government. There are 29 such posts.

Subordinate to the "Oberforstmeister" are the "Forstmeister," more or less corresponding to our staff of Upper Control. Of these there are 92.

Under these serve the "Oberforsters," corresponding to our Rangers and Extra-Assistant Conservators. There are 679 "Oberforsters," who, in regard to all police administration, are subordinate to the "Landrath" (Collector), but in all technical business to the "Forstmeister." Their average charge is about 17 square miles.

The whole of the account work is done by 388 Accountants, who each deposit a security of £200, and are paid by a percentage subject to a minimum income. Since 1888-89 these officers are gradually being brought on fixed salaries.

The protective establishment consist of 5,208 Foresters and Guards. Permanent mates of working-gangs are sworn in as

special guards, but receive no extra pay on this account. In cases of special necessity, non-commissioned officers and soldiers are detailed for forest protection.

As regards emoluments—

The "Oberlandforstmeister" receives a salary (inclusive of house-rent) of 18,000 marks per annum. When travelling on duty he gets actual travelling expenses, *plus* a daily allowance of 24 marks.

The "Landforstmeisters" receive from 9,900 to 12,000 marks per annum.

The "Oberforstmeisters" draw a salary of 9,000 marks per annum, *plus* a direction allowance of 900 marks which is pensionable.

The "Forstmeisters" are on salaries ranging from 6,500 to 9,000 marks per annum. When moving on duty they receive a daily allowance of 18 marks, *plus* 0.13 of a mark per kilometer when travelling by rail or steamer, 0.60 of a mark per kilometer when travelling by road, and 3 marks on each occasion they enter on or leave either a steamer or the railway.

The "Oberforsters" are paid on an average 3,000 marks, per annum. This pay is pensionable. They also draw a personal allowance of 2,100 marks per annum which is not pensionable, and when travelling beyond the limits of their ranges they are allowed 12 marks a day, *plus* 0.13 of a mark for each kilometer travelled by rail or steamer, and 0.60 of a mark for each kilometer travelled by road, besides 3 marks for each occasion they enter on and leave a steamer or the railway.

The "Forsters" are on salaries ranging from 900 to 1,300 marks a year. Such of them as possess the title "Revier Forster" are granted, in addition, an allowance ranging from 150 to 450 marks per annum, free house, and free firewood averaging in value 297.6 marks per annum. The value of this last grant counts towards pension. When travelling on duty Forsters are entitled to a daily allowance of 3 marks if proceeding by rail or steamer, and of 6 marks if proceeding by road, besides 0.10 of a mark for each kilometer travelled by rail or steamer, and 0.40 of a mark for every kilometer travelled by road.

The "Waldwárter" (corresponding to our Forest Guards) get from 360 to 660 marks a year, and most of them are allowed firewood for whatever its exploitation costs.

All officers when transferred from one part of the country to another in the interest of the public service are granted compensation.

As regards pensions, the amount admissible is determined, by length of service. After a service of not less than ten years, a pension not exceeding 15/60ths of average salary is admissible.

After ten years' service, the rate of pension increases by 1-60th of average salary each year. The maximum pension admissible on this scale is 45-60ths of average salary.

In the case of classes divided into grades or having appointments on progressive pay, not more than the average pay of the appointment can be taken into account in reckoning for pension. As regards salaries above 12,000 marks per annum, only half the excess is pensionable.

Service begins at 21 years, and every year's war service counts double. All pensions due on account of accidents in connection with the service are fixed at 2-3rds of the salary, independent of the length of service.

In the case of an officer dying, his wife and children, or (with special sanction) other near relatives dependent on him, are entitled to a gratuity equivalent to the pay of the deceased for three months. In the case of an officer who dies with a claim to pension, his widow receives, in addition to the above, 1/3rd of the pension he was entitled to at the time of his death and each of his children 1/9th.

In addition, the State supervises and guarantees insurances managed free of profits.

The average gross income from State forest property in Prussia is about Rs. 6 per acre.

There are several points in our forest administration which I should like to see further assimilated to that of France and Germany, and it will be my constant aim to effect this in the course of time; but, as they are wide of my present purpose, I shall not further refer to them in this note.

The most carefully-trained and selected controlling staff is helpless in regard to an efficient management of the forests entrusted to it, if unassisted by an adequate staff of executive officers—adequate both in numbers and technical knowledge. This fact has been fully recognized by the Government of India; and if I, nevertheless, once more enlarge on the subject, I do so with reference to the too moderate demands for an increase in the executive (especially the Ranger staff,) which some of the Local Governments have submitted, and which will prove to be inadequate before many years have elapsed.

Most of our Indian forests have suffered for centuries from mismanagement, or, if not from direct mismanagement, from neglect. From time immemorial the produce required by the people or by the State had been extracted where most convenient, without regard to the future well-being of the forests. Growing poles were lopped for fodder or cut for other purposes at the height most convenient to the workmen; fires were never checked, and grazing was permitted on areas where natural reproduction took place. The results of all this were more or less ruined.

forests. Protective measures which have been gradually introduced during the last 30 years, have had the most beneficial results, both on the reproduction of our forests and the improvement of the growing-stock ; but we cannot by such means alone improve the forests to the degree which is desirable. This can only be done by the extraction of all trees damaged beyond recovery ; by the removal of inferior species and of old decaying standards which appropriate more space, light and food than they are worth, either as growing-stock or as parent trees. In fact, improvement fellings are required over a great majority of our Indian forests, and the sooner they are executed the better it will be. The officers of the Controlling Staff can, on an examination of each forest, lay down the principles on which such fellings should be conducted ; but their charges are much too vast to permit of their personally seeing their orders carried into effect, and it is a more difficult task in silviculture to supervise the correct use of the axe than is that of the spade or hoe in agriculture.

What is required, then, is a specially educated executive staff for silvicultural more than for any other purposes, though even the latter (such as timber-export, road-making, disposal of material, fire-protection, &c.,) cannot be carried into effect without a staff composed of men of sufficient intelligence and training. The centre of gravity of the most efficient forest organization must for ever lie in an adequate executive staff, sufficiently trained to carry into practical effect the provisions of working-plans, and to execute correctly the general orders or prescriptions issuing from Divisional Officers.

10. It is necessary to take next into consideration not merely the annual recruitment of the above proposed staff, but the initial recruitment. The rules in force prescribe that in future the staff can only be entered through one of the Indian Forest Schools ; and whatever may be the difficulties arising in consequence of the large demand for competent men, they must be met by efforts made at the centres of forest education, and only under the most exceptional circumstances should a relaxation of the rules for entry into the Upper Executive Staff be permitted.

Local Governments are empowered to give scholarships to approved candidates while pursuing their course of study at the Forest School, and, until the staff is fully formed, there should, I think, be no limitation as regards the number of such grants to be made by Local Government in the case of the Dehra and Poona Schools, so long as the aggregate amount sanctioned for ranger-ships is not exceeded. For some years to come this amount will not be absorbed, because it will take time to procure the number of efficiently trained Rangers required for the proposed expansion of the service.

I find greater difficulty in dealing with the staff of Foresters and Guards than I have had in formulating proposals as regards Rangers, probably because I have no personal faith in this part of the organization.

There is, in my opinion, no necessity for the strong connecting link, which we do not find in any other forest organization, between the executive and protective staff. It seems to me that, for years to come, the less important ranges must for economy's sake be placed in charge of Foresters in the upper grades, some of whom will, it is to be hoped, when a sufficient number of trained officers become available, be hereafter absorbed into the Rangers' class. I also think that there are some depôts and other special works which are of too great importance to be placed in charge of Guards; and finally it appears advisable to have some exceptional posts to which very deserving Guards might be promoted, obtaining a sort of honorary title with a little higher pay attached thereto. But I do not see the necessity for securing a steady flow of promotion from class to class because the classes are so entirely different as regards the education and attainments required from them. In the former Circular all Foresters were included in the protective staff; but this is a fallacy, as it is proposed to place a considerable number of them in charge of executive appointments.

In the circumstances above explained, I suggest that no distinction be made, in the designation of officers who enter the Ranger class under the same rules and restrictions, and I think that all such officers, on Rs. 50 to Rs. 150, should be designated as *Rangers*.

As regards untrained officers, or such as hold a Forest School certificate by the lower standard, who are placed in executive charges, I propose that they should be placed on grades of Rs. 40, 35 and 30, and be designated as *Deputy Rangers* forming the Lower Executive Staff. I would abolish the intermediate grade of Rs. 25, so as to destroy the connection between the executive and protective establishments, and suggest the formation of a class of *Foresters*, or members of an Upper Protective Staff, on Rs. 20, 18 16 and 14, below which would follow the last link of the chain—the *Guards*, or Lower Protective Staff—on such pay and of such grades as local circumstances may require.

It will be observed that I have adopted nearer intervals of pay in the lower classes. As regards Rangers, these intervals vary from Rs. 10 in the lower to Rs. 25 in the upper grades; for Deputy Rangers I have adopted Rs. 5, for Foresters Rs. 2 and for Guards I think the intervals ought to be fixed at Re. 1; but this, as I have already pointed out, must be dependent on local conditions.

Below is a *résumé* of my proposals for the re-organization of the lower executive and the protective staff in the provinces

under the Government of India. The proposals made by Local Governments and Administrations amounted to Rs. 56,692 per mens-m; my modification involves an aggregate cost of Rs. 56,477 :—

Résumé.

PROVINCE.	DEPUTY RANGERS.		FORESTERS.		GUARDS.	
	No.	Cost per mensem.	No.	Cost per mensem.	No.	Cost per mensem.
		Rs.		Rs.		Rs.
Bengal	60	2,100	60	1,020	413	3,716
North-West Provinces & Oudh	30	1,050	24	408	407	3,367
Punjab	24	840	64	1,088	*690	5,280
Central Provinces	60	2,100	180	2,060	1,675	12,562
Burma	60	2,100	132	2,376	452	5,720
Assam	24	840	18	302	300	2,462
Coorg	6	210	18	302	91	771
Ajmere	5	86	42	294
Andamans	5	170
Baluchistan	3	105	8	142	55	612
Berar	40	1,390	44	748	157	1,256
TOTAL INDIA ...	312	10,905	553	9,532	4,282	36,040

* and 105 Rákhas.

The total cost of the lower executive staff for India amounts, in accordance with my proposal, to Rs. 1,40,860 per annum; that of the protective establishment to Rs. 5,46,164.

For Madras I propose for the lower executive staff—

Deputy Rangers 60 costing Rs. 2,100 per month.
 Foresters 144 " " 2,448 " "

I propose also 1,004 *Guards* on an average pay of Rs. 8-8 (which, in my opinion, is sufficient), costing Rs 8,534 per mensem.

My re-cast of the proposals costs Rs. 13,082 per mensem.

I propose for the lower executive staff in Bombay.

Deputy Rangers 72 costing Rs. 2,520 per month.
 Foresters 272 " " 4,624 " "

I propose to absorb into this scale the 125 1st grade *Guards* on Rs. 15 each per mensem asked for by the Committee, which is reasonable in that both *Foresters* and *Guards* belong to the protective staff. The number of *Guards* thus proposed by me is 3,590, at a monthly cost of Rs. 29,680. The cost of these proposals is Rs. 36,824.

The following is an abstract of the proposed re-organization of the forest staff below the rank of Extra-Assistant Conservators :—

	EXECUTIVE STAFF.						PROTECTIVE STAFF.						Grand total of Cost.		Amount for which sanction is required.		
	UPPER EX-ROUTINE STAFF.		LOWER EX-ROUTINE STAFF.		TOTAL.		FORESTERS.		GUARDS.		TOTAL.		Rs.	Rs.			
	Rangers.		Deputy Rangers.		No.	Cost per annum.	No.	Cost per annum.	No.	Cost per annum.	No.	Cost per annum.	No.	Cost per annum.		Rs.	Rs.
	No.	Cost per annum.	No.	Cost per annum.													
India ...	291	2,69,220	312	1,30,860	603	4,00,080	553	1,14,384	4,282 & 105 Rakhas	4,32,480	4,940	5,46,864	4,940	5,46,864	9,46,944	2,88,716	
Madras ...	109	99,408	60	25,200	169	1,24,608	144	29,376	1,004	1,02,408	1,148	1,31,784	1,148	1,31,784	2,56,392	1,06,608	
Bombay ...	102	91,680	72	30,240	174	1,21,920	272	55,488	3,590	3,56,160	3,862	4,11,648	3,862	4,11,648	5,33,568	1,18,992	
Total of Empire ...	502	4,60,380	444	1,86,300	496	6,46,608	969	1,99,248	8,876	8,91,048	9,950	10,90,296	9,950	10,90,296	17,36,904	5,24,316	

Sufficient justification for all proposals is, I think, contained in the provincial applications for the necessary increases, which, in my opinion, are, in several instances, framed with too little regard to the future capabilities of the State forest.

It is impossible to promise an immediate expansion of the revenue as a result of the increased establishment, though I believe the gross revenue will still grow considerably; but I may safely say that without an adequate executive and protective establishment, it is impossible to maintain the present revenue and at the same time improve the status of the forests entrusted to Government.

It should be understood that while the present proposals generally provide, so far as the numerical strength of the establishment is concerned, for the normal increase during some years to come, consequent on the development of the forest management of such areas as are already controlled by the Forest Department, they can be regarded as tentative only in others; and in no case does the suggested scale provide for any considerable increase of establishment consequent on extension of the areas placed in charge of the Department.

Such extension is contemplated in Bengal, especially as regards the Chittagong tracts. It is likely to occur in Baluchistan by the assumption of the control of the Zhob Valley forests; and it may take place in the Central Circle of the North-Western Provinces by the absorption of the district forests, which are at present managed by the district officers with an entirely inadequate establishment. As regards Upper Burma, it is as yet quite impossible to form the scale of establishment which may be ultimately required, and it is necessary to be prepared for new demands being made as the result of the development of new resources.

It is a question for consideration whether the amount sanctioned for the subordinate staff should be granted to Local Governments in lump sums, or on account of the preconsidered scales exhibited in the foregoing pages. I am entirely in favour of the latter alternative, at least as regards the upper and lower executive staff; for, in order to secure good and efficient officers, it is necessary to hold out reasonable and sufficient prospects; and this can only be accomplished by a fixed scale of appointments, which should be made known as widely as possible, so that the public itself may judge of the prospects offered.

Though several Governments have submitted proposals for the reorganization of the clerical staff, I have intentionally abstained from taking up this question along with the reorganization of the subordinate forest staff.

IV.—REVIEWS.

Report on the operations of the Department of Land Records and Agriculture, Madras Presidency, for 1890-91.

We lately had occasion to remark, in reviewing a Bombay Agricultural Report, on the pity it was that the Report could not have been reviewed by a professional instead of by a series of amateurs, and a perusal of the Report now before us confirms our opinion. The author, presumably the Director of Agriculture, tells us, speaking of the Saidapet College and Farm, that, "The Director (of the College) is in the future to be 'consulted in all matters regarding the management of the 'Institution' and if we are thus to suppose that hitherto he has not been so consulted, we can only wonder that the College has done the good work it undoubtedly has.

The only part of the Report of interest to Forest Officers, is that on the question of pasturage and fodder. We see it stated that:—"The Government has now emphatically declared that the 'chief object of the Reserved Forests throughout the greater part 'of the country is the provision of pasture, small timber, fuel, and 'leaves for manure or litter, and that they are to be worked 'in order to meet the wants of the villagers in these respects 'and are not to be converted into close reserves for the growth 'of large timber." We can only hope that some Madras Forest Officer will explain to us exactly what this means. We can cordially agree in the advisability of working the forests in an agricultural country chiefly for the supply of local wants; but this seems to us a little too sweeping an order, for we know very well that the average condition of the Madras plains forests is such that without rest, not merely for a year or two, but for long, in order to recover some of the lost 'humus' and allow new seeds to germinate, new grass to grow, and old maltreated trees and bushes to recover, many of the Reserved Forests will not be of much value even for pasture, small timber, fuel and leaves.

In our opinion, the policy of the Government of India of dividing the Forest area into Timber Forests, Pasture Forests and Forests for the supply of local small wood and cut grass, and then working each class in an appropriate manner under a regular plan is more likely to give good results, and result in supplying the wants of the villagers at the same time as it ensures a gradual improvement of the capital stock.

Administration Report on the Railways in India for 1891-92.

In our June number we reviewed Part II of the Report for 1890-91. Part I of that for 1891-92 has now come to hand and so we have now a few additional remarks to make on points of interest to our subscribers. This also has an excellent map shewing all the Indian Railways and brought up to the date of March 31st 1892. It has also an interesting diagram, shewing, plotted as curves, the capital outlay, working expenses, gross earnings, net earnings and number of miles open of Indian Railways from their first commencement in 1853 to date.

On March 31st 1892, the length of Railway line in India was :—

		Miles.
Standard Gauge 10,104
Metre	..	7,172
Special Gauges	...	288
Total		.. 17,564

as well as about 38 miles of steam Tramways outside Municipal limits. There are also 1697 miles of sanctioned extensions to be constructed or under construction, the chief work of which is the Assam-Bengal Railway which is to reach the coast at Chittagong after a run of 742½ miles.

The chapter of most interest to us, as Foresters, is that on Fuel consumption, from which it would appear that 340,038 tons of wood were burnt in 1891 against 326,252 tons in 1890. For most of this the Madras, Southern Mahratta, and North-Western Railways are responsible, the amounts being :—

		tons.
Madras	Railway	... 82,776
Southern Mahratta	..	66,233
South Indian	..	6,577
Bengal and N.-Western	..	1,876
North-Western	..	47,186
Burma	..	2,642

The rates were various, from Rs. 7-8 per ton on the Mysore Section of the S. Mahratta, to Rs. 2-7-3 per ton on the Bengal and North-Western.

It seems to have been anticipated that the Tondu Reserved Forests of the Western Dooars of Jalpaiguri would supply the whole of the sleepers for the Bengal Dooars railway, but enquiries prove that only 18,000 will be so available, so the rest are being obtained from other Bengal Forest Divisions and from Burma. The only other mention of wooden sleepers is that one lakh of deodar and half a lakh of creosoted pine are being put down on the Bhávnagar-Gondal railway.

Forestry in South Australia.

The report of the administration of the State forests in South Australia for the year ending 30th June, 1891, shews a total area of 227,135 acres, or about 355 square miles, about the equivalent of a single forest division in India. Mr. Walter Gill, who writes the report, was appointed Conservator on the 24th July, 1890, so this is his first report, after one year's experience as to the working of the forests. Out of the total area of forests under his control, it seems that 10,000 acres are enclosed for planting and "encouraging the natural growth of trees in the 'indigenous forests.'"

Of the former, as in all Australian Reports, we hear a good deal; of the latter, very little. In the planting operations, 439,058 plants were put out, chiefly sugar and other gums, three European pines, poplar, willow and larch. But more than half died within the year, much of the damage being due to grasshoppers. The planting of the gums appears to be effected in bamboo tubes.

The natural reproduction is due to forest fires, which swept through the country for miles, resulting, however, in a crop of young seedlings under the parent trees, especially of various kinds of eucalyptus. Unfortunately as Mr. Gill points out, "the good 'thus effected in the first instance is too often subsequently nullified by a repetition of the fire when it is not required.'"

The timber operations embraced the delivery of 13,000 broad-gauge sleepers and 40,000 posts to the railway authorities, besides a lot of 10,000 smaller—metre gauge, apparently—supplied from various depôts. We would like to ask what security there is for keeping up the stock in the Wirrabara forest when so much timber is removed? We read that timber was carted from this forest thirty years ago, and has been obtained from there ever since, and "the wonder is, not that the available supply should at length have reached its limit, but that it should have lasted such a length of time." How has this timber been replaced? What is the condition of the young crop, or is there none?

Then again, what does the leasing of certain reserves imply? What rights does the lessee purchase; what conditions is he bound by? These and many other questions occur to us naturally, for without an explanation, the report is incomprehensible on these particular points. Attempts were made to plant out vine cuttings, olives and certain pines near a fresh-water lagoon in the Hundred of Ramsay, but a salt deposit, something like our friend the *Reh*, subsequently made its appearance, and the nursery had to be abandoned. There seems to be a large area of scrub land liable to this saline efflorescence; scores of farmers have taken up selections on these lands and have retired in disgust after a year's or two year's experience. All the best land is in private hands.

A large number of plants are distributed every year to applicants for putting out, with more or less success, the results on the whole not being satisfactory. However, more attention is being paid to this subject and we many hope for better reports in future. Arbor Day is a feature in the colony, "the children 'entering most zealously into the enjoyable outing;" we must trust that the 25,723 trees were properly planted on this occasion. Mr. Gill has nearly one million plants in his nurseries, so there is no fear of artificial reproduction not being kept up.

The total revenue of the South Australian Forests is £4,043 and the expenditure £8,017, nearly two thirds of the revenue comes from rents from lands leased and let (about which we should like to hear more) and half the expenditure is due to wages, nurserymen, foremen, laborers, &c. Besides the expenditure, as given above, however, there were special votes amounting to £2,375, chiefly incurred on planting.

An interesting feature in the report is the account of the cultivation of the date palm, the ultimate success of which appears to be probable. An endeavour is being made to obtain suckers from Karachi, through the agency of the Afghan colony at Hergott, the place where the cultivation of this palm is being tried. Mr. Gill, on comparing the conditions under which the palm is grown by the French in the Sahara, and those obtaining at Hergott, has every hope of success; of the importance of the experiment in a hot and arid country like South Australia, there can be no doubt.

A. S.

V-SHIKAR.

A trip to Bara Bangahal.

23rd May.—Left Yarra at dawn for Surai, the path lies along the face of very precipitous and dangerous ground and the journey is a decidedly sensational one. The famous "Kali-dhog," (Black-rock) is crossed soon after passing the liquor distillery below Yarra. Steps have been cut across an enormous black rock below which is a sheer drop of probably two or three hundred feet. The steps are slippery and nasty going. They are said to have been made at the request and expense of one of the Ranies of Nadaun (Kangra District) an inhabitant of these parts, some time prior to the Mutiny of 1857. Reached Surai about 1 o'clock p. m. just as a heavy shower came down. The scenery all round is very wild and grand. The Ravi runs in a deep and narrow valley below and is a roaring, foaming

torrent here. The forests of Blue Pine, Webbiana and Smithiana, are lovely, for they have never been subject to the ill usage suffered by forests situated within the reach of traders and villagers. The winter here is very severe and the inhabitants of this little village lock up their dwellings and clear out of the valley in October and November and do not return again till the end of May or June. Only two men had arrived in the village, and from these we tried to obtain grain for the coolies; after a bit of a search, a small quantity was produced. One of the houses had been broken into by bears and the huge grain basket turned over and the contents devoured.

24th May.—Queen's Birthday. God bless Her. Started early and saw marks of bears all along the path and in the "gotes." There is excellent bear shooting all round here, but I was anxious to get to Bara Bangahal, and could not stop to prospect. Path very bad going, over dangerous ground. At Oorna, saw a brown bear and cub but could not get near enough for a shot. After passing Oorna, the path lay along a nasty landslip, then down the face of a cliff, and finally the Ravi is crossed by a very rickety twig bridge. The enormous bare cliffs above the bridge are almost perpendicular, and are strikingly impressive. Got to Giraunda, a small village, very tired and fatigued, owing to the constant tension on one's nerves, for you cannot help realising what the result of a false step would be on such ground. There is splendid "Chôkôr" shooting all round the village.

25th May.—Halted at Giraunda, as the weather looked very threatening, and the villagers advised us strongly not to attempt the journey beyond, in wet weather, as there were many dangerous landslips to cross, and rocks were constantly rolling down from the cliffs above. There is very good bear ground all round here, if one only had the time to go round it.

26th May.—Started late, not feeling particularly well. This is certainly the most dangerous portion of the whole journey from Palampur to Bara Bangahal. The landslips to be crossed, with the constant falling of huge stones from the cliffs above—the bare rocks to be scaled down, with nothing but the cracks and crevices in them to hold on by and then the final climb up a sheer precipice, with positively no more than mere ledges as broad as the palms of one's hand to rest your feet on, makes this march a very trying and fatiguing one. It was here that Colonel Tanner of the Survey lost his fox terrier, which fell over a precipice. I had to get my dogs carried in blankets for no four footed animal could possibly climb up these cliffs. Passed the village of Khanâr about 1 o'clock; there was not a living soul in it, none of the villagers had returned since their exodus in October last. The empty houses were in possession of heaps of "Chôkôr" which were as tame as barndoor fowls. Reached the Khâla-pâni, gote about 4 or 5 p. m. and though it is a bad camping ground,

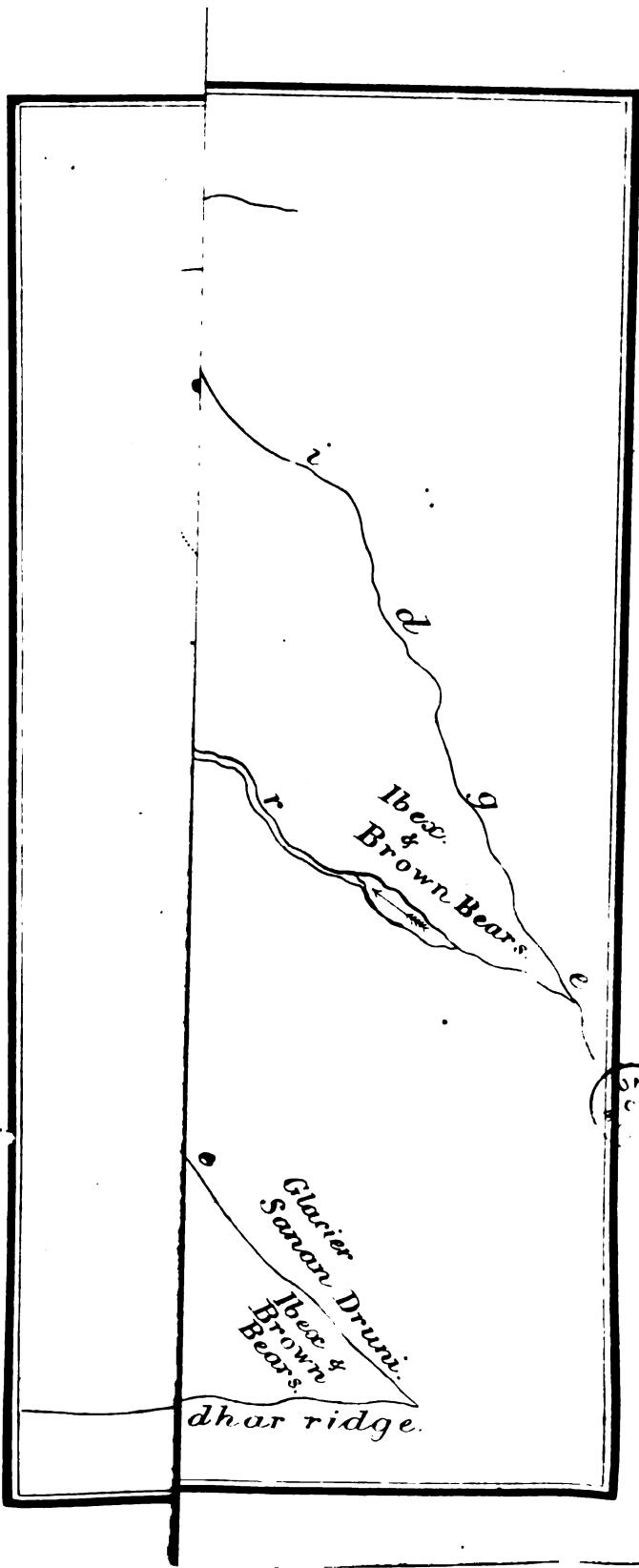

I was glad to finish the day's journey and turn into bed for I was dead beat. The wild rhubarb and onion grow profusely all round here and as I had had no vegetables for some days, I was glad to accept the Khansama's proposal to have some of the rhubarb cooked for dinner. The best way to cook it is as follows :—

Peel the flower stalk, boil it to a soft pulp, strain off the water carefully, then cook up the pulp with a little ghee and salt or butter if you have such a luxury in camp.

The young fronds of the large sized fern whilst they are in their curled up state, are not at all bad eating, cooked up like spinach. The wild onions are too strong.

27th May.—Up very early—feeling very fit—probably from the rhubarb eaten last night. Road still very bad; the dogs had to be carried in blankets. Reached the village of Bara Bangahal about 3 p. m. and was delighted to see broader valleys and easier hill-sides.—Here are situated the head waters of the Roir, a roaring and foaming torrent. Bara Bangahal has an area of about 290 square miles, but contains only one village, situated at the lowest point of the valley, some 8,500 feet above the sea. Some 12 or 13 years ago a number of the houses were swept away by an avalanche. On all sides, the mountains slope steeply up from the river, and rise into peaks of from 17,000 to 20,000 feet in height. Deodar and Blue Pine are in compact patches in the lower ravines; above these are long bare slopes of splendid grazing lands, to which the flocks of sheep and goats from Mundi, Palampur and lower Bangahal resort during the three summer months. Above the grazing grounds come glaciers, bare rock and cliffs, and fields of perpetual snow. The rough sketch appended shows the position of the valleys, streams and forest lands and the places where the brown bear and ibex may be found. It is a very wild and dangerous country to travel over, but the climate is glorious and the feeling that you are in a thoroughly wild and uninhabited region is very exciting and pleasant. Mine is an article on "Shikar" and so, I will not here describe the forests.

28th May.—Up early and visited the Deodar Forest opposite my camp. After breakfast moved camp to a very jolly flat up the Kali Hein Nala. Most lovely looking bear ground; for miles nothing but beautiful grassy hill sides and "gotes" the favorite feeding grounds of brown bears. High up the ridge above us, I spotted a splendid large brown bear but he was on the move making for the Roygar nala valley; directly after, I saw another a long way off in the deep snow, but as the rain came down in torrents, had the tents pitched and turned in.

29th May.—Left the Challa-gote very early and reached the Kumbhêd gotte about 2 o'clock; the path runs along lovely grassy hill sides, which unfortunately swarm with ticks. These little pests drive one nearly mad, for their bite is very venomous, and

stings like a hot coal on the skin. The people say that in some places where they swarm, sheep are occasionally killed from the bites of the numbers that attack them. Got an attack of fever and ague and had to turn in.

30th May.—Started early up the valley to look for Ibex. Ground awfully bad. Just as I was sitting down to tackle my breakfast, I spotted three Ibex; left the breakfast and cooly behind a rock and stalked the fine looking beasts on the cliffs above us, got within 120 yards of the largest head in the herd and knocked him over, but before we could get up, he had picked himself together and cleared off over some very dangerous ground where we could not follow: however the shikary said he knew a way of getting round the obstacle and off we started again; we had not gone very far, when the shikary spotted a young male standing sentry on the top of a high rock, he was certainly not worth shooting but as the shikary begged hard that I should try and bag him to supply the camp with meat, I got an easy shot at him and bowled him over. With our load we started down the hill to camp, as I was only too willing of an excuse to get in and have a cup of tea and something to eat, for I had lost the breakfast cooly. Received a post in the evening and remained in camp to answer it.

31st May.—Started after breakfast with Barêrū Shikary to hunt up the wounded Ibex. He had climbed up into very dangerous ground, where I felt I could not follow, so gave the rifle to the shikary to finish him off. After a bit of searching, he spotted the wounded beast lying in a deep ravine, where he could not be got at and so drove him out with stones. He came down towards where I was standing and gave me an easy shot which finished him off. How on earth he had ever got over such ground after the wound he had had the day before, was a wonder to me, for he had a huge hole high up in his hind quarters into which I could put my hand. I was very glad of my trophy, though it is by no means a fine head. Got back early to camp, and prepared to move lower down the valley again. The Shikary and I started ahead of the camp to look for bears. Soon we spotted a she bear and two cubs low down in the nala. I bagged the she bear with the first shot, and then watched the extraordinary behaviour of the two cubs, these jumped and danced on their hind legs round their dead mother, then not finding her rise, they smacked her over the head, bellowing all the while, and then finally bolted down the hill: they were too small to shoot, so I amused myself calling to them and more than once got them to come up within thirty yards of me while I lay hidden behind a dead tree. Got into camp late, very pleased with myself and every one else.

(To be continued.)

F. O. L.

Forest School Sports at Dehra.

The annual sports of the Imperial Forest School were held on the old parade-ground at Dehra on Saturday afternoon, October 22nd, under the supervision of Mr. Gamble, the Director of the Forest School; Mr. Smythies, the Deputy Director; and Messrs. Gradon and Gilbert Rogers, the instructors at the School. The students this year number 104, of whom 32 are Europeans, and 72 natives of India, a marked increase over the numbers last year, which were 26 and 50, respectively. A beautifully clear, cool autumn day brought the whole of Dehra to the parade-ground, to witness the various competitions, which were very well carried out, and keenly contested, the greatest interest being shown by the native assemblage—Gurkha, Sikh, Pathan, and Hillman alike. The best contested events were the 100 yards' hurdle race, and half mile, especially the last, which was run in excellent style, the winner having lots of go in him at the finish. The long jump would have been a certainty for F. J. Langhorne had he not each time overstepped the line. The various events and winners were as follows:—

1.—*Flat Race.* Distance 100 yards.

R. H. Cole	... 1
F. J. Langhorne	... 2

Time— $11\frac{3}{5}$ secs. A very close race. Only 6 inches between first and second.

2.—*Long Jump.* One prize, open to whole School, and one prize for native students.

W. J. Lane-Ryan	... 1
Ethirajulu Naidu	... 2

The winner jumped 16 feet 2 inches; the second 15 feet 8 inches.

3.—*Hurdle Race.* Distance 120 yards, over 10 flights of hurdles.

F. J. Langhorne	... 1
J. F. Tweedie	... 2
W. J. Lane-Ryan	... 3

Won by a yard. Tweedie's jumping was much admired.

4.—*Throwing the Cricket Ball.*

W. J. Lane-Ryan	... 1
J. H. Firth	... 2

The winner's throw was 96 yards 8 inches.

5.—*Flat Race.* For native students only. Distance 220 yards.

Ethirajulu Naidu	...	1
Ratan Chand	...	2

Won by a yard, after a very good race. The winner a splendid specimen of a Peninsular race.

6.—*Putting the Shot.* 16lb.

W. J. Lane-Ryan	...	1
R. G. Hannah	...	2

The winner putted 34 feet 1½ inches.

7.—*High Jump.* One prize open to whole School, and one prize for native students.

W. J. Lane-Ryan	...	1
Ethirajulu Naidu	...	2

The height jumped was 5 feet 1½ inches; the second 4 feet 10 inches.

8.—*Half-mile Race.* Open to whole School.

T. C. Legge	...	1
S. A. Wood	...	2

Won by 3 yards; a splendid race; won easily. Time 2 mins, 24 secs.

9.—*Flat Race.* For School servants. Distance 100 yards.

Krishna	...	1
Sati Din	...	2
Fateh Singh	...	3

10.—*Flat Race.* For men of the 2nd P. W. O. Gurkhas. Distance 100 yards.

Tikram Kunwar	...	1
Nathu Damar	...	2

The invincible champion of the 2nd Gurkhas easily secured another victory. Time—11½ secs.

11.—*Tug-of-War.* Seniors vs. Juniors, 12 on each side; 3 tries.

The juniors won the first try, but exhausted themselves, and lost the second and third tries amidst great excitement.

At the conclusion of the races the prizes were presented to the winners by Mrs. Smythies, for whom three hearty cheers were given, followed by cheers for Mr. Gamble, and the School staff.
—*Pioneer.*

VI.—EXTRACTS, NOTES AND QUERIES.

On Judicious Pruning.

BY WILLIAM M'CORQUODALE, FORESTER AND WOOD SURVEYOR,
SCONE, PERTH.

IT is to be regretted that there are so many conflicting opinions on this subject. Some authors strongly advocate the advantages of skilful pruning, while others positively deny that any advantage accrues from even the most judicious pruning.

In the English Crown Forests, pruning was abandoned some thirty years ago. Following that example, the same course has been adopted on many private properties in both England and Scotland.

Some theorists declare that there is such a connection subsisting between the roots and branches that when a live branch is removed all the corresponding roots supporting that branch immediately cease to perform their functions and die.

I well remember, nearly forty years ago, having an interesting conversation with an able arboriculturist on the subject of pruning, when he substantially denied that the art of pruning in any shape or form would do good. He maintained that when a live branch was taken off a tree, the roots in the ground supporting that branch would die. After a considerable amount of discussion, I asked him to answer one question in support of his theory, and I would be satisfied. That question was—"Why is it that, when a healthy oak tree is cut down, the roots do not die; but, on the contrary, continue in vigorous action, and the stool immediately produces a healthy crop of shoot?" To this question he gave no reply.

Soon after this, I resolved to try experiments to enlighten myself on this subject by sowing a few seeds of *Abies Douglasii* in a convenient corner in my garden, to see if I could make any satisfactory discovery relative to the subject of our discussion. From these seeds I reared one plant for four years till it was about 3 feet in height. During that period I never allowed even a bud to form on the stem of this plant. So as soon one appeared, it was at once rubbed off. The plant, notwithstanding, grew with a beautiful clean, straight stem; but unfortunately, in the fourth year of its growth, in autumn, when the hedger was engaged cutting the garden hedge, he accidentally broke it over near the surface of the ground. However, it had answered my purpose very well. I grubbed up the root carefully at once for inspection, and, to my agreeable surprise, found it unusually large for a plant of its size, seeing that it was never permitted to produce the semblance of a branch. The root was divided into three large

forks, and these were matted with healthy fibrous rootlets at their extremities. From my friend's point of view, I expected that this plant, which was reared branchless, would have no other root but the tap-root; but I found no difference in the ramification of its roots from that of young plants of the same age having the whole of their natural branches.

I shall add another illustration as to the connection subsisting between the roots, branches, and stools of trees, which, together with the foregoing remarks, will, I trust, go far in confuting the opinion entertained by certain theorists that the removal of a live branch will prove fatal to the corresponding roots supporting it.

I have repeatedly fallen in with pine-root stools which continued their vitality for many years after the tree was cut down, with the face of the stool healing over from the outside as regularly round the whole stool and in the same way as a wound on the trunk of a tree after a branch has been pruned off. In all such cases it was found that the stools had—prior to the trees being cut down—roots united with, or naturally engrafted into, roots of an adjoining tree of the same kind, which roots continued to draw sufficient nourishment from the standing tree for the support of the stool for years after their own tree was cut away.

About ten years ago I found a larch stool in Scone Wood about ninety years of age, the stem of which had been cut off some ten years previously. This stool was a solitary one, too far apart from any larch or other fir tree to nourish it. Yet this stool was in life; growing and healing all round. I got men with tools and laid its roots bare. They were all far gone with decay, save one, which was quite fresh. I traced it to its nurse, and found it to be lying across, deeply embedded, and strongly engrafted into, a healthy root of an adjoining ash tree. How is it that this engrafted root, without the aid of a green leaf, nourished the whole stool, giving circulation to the sap all round, and producing sap-wood and bark? This is a question for botanists and theorists to solve.

Judicious pruning is a very important branch of forestry. I do not hold that even judicious pruning will, as a whole, augment the bulk of timber in a tree; but, from my experience of fifty years, watching the beneficial result of its effect upon trees under my management, I certainly hold that early periodical pruning, when skilfully pursued, will have the effect of producing ultimately a much larger yield of clean, straight, valuable timber per acre than would have been the case had the trees remained in a natural condition. No doubt there are individual trees that on certain soils grow naturally tall and straight in the bole, and therefore require but slight artificial training; but, generally speaking, with few exceptions all oak trees require skilful training, and when trees are properly treated in this manner a larger number can be reared per acre, and are not so likely to be blown over by high gales, or to have their limbs torn off.

I should fancy that the opponents of pruning never themselves had the advantage of seeing the beneficial results of systematic pruning. The benefit accruing from such training is not be obtained in a few years. An arboriculturist treating a young plantation in this way, and following up its training, may be forty or fifty years before seeing the actual result of his operations. Of oaks that were pruned at Scone under my direction forty-five years ago, hundreds are at present being cut up at the saw-mill for the building of railway waggons, and to me it is most satisfactory to find the timber so sound, free from blemishes, and beautiful.

I have seen pruning so barbarously performed and the trees mutilated in such a manner that it must have proved disastrous in the highest degree, ruining the constitution of the trees, retarding their growth, and ultimately yielding faulty timber. Such pruning should not upon any account be tolerated; and when the timber comes into the hands of tradesmen it is no wonder that pruning is condemned. But the effects of judicious pruning are of an opposite character.

Young oak trees from the nursery to be planted in the forest should receive no further pruning than the shortening of contending shoots or strong side branches. When they arrive at six or seven feet in height they should receive a regular course of training by pruning, which can be performed almost wholly by the use of the pruning knife. The operator should always begin at the top of the tree, shortening shoots which rival the leader more than half their length. Strong rambling side branches should also be shortened fully one-half; and when a tree is overcrowded with branches low down, some of these ought to be thinned out and pruned close to the stem. Young trees at this stage of growth should be so well balanced and shaped that little or no pruning will be required for several years after.

In the next course of pruning, the operator ought to be provided with ladder, pruning-saw, pruning-knife, and shears on long handles. Before ascending the tree, he should examine it minutely, and see what will be required to balance and shape the tree properly. After ascending, he should begin at the top, shortening the rival leader, if there be one; but as there is often a difficulty in reaching a rival top, the pruning-shears are brought into requisition to shorten it.

The operator, in descending the tree, should shorten extra strong branches at least half-way in. These would always be cut at a lateral small branch, or twig, of an upright growth. Strong branches growing pretty low on the bole should be shortened well in near the bole, in order to throw vigour up the stem of the tree. At this course of pruning, a few branches ought to be pruned away at the bottom, close to the stem. Other successive courses of pruning should be conducted on the same system, with this addition, that more branches will be required to be pruned close to the bole.

The point to be studied for the safe guidance of the operator is—what is the largest size of a branch that can be pruned from the bole without leaving any blemish in the timber? The health and vigour of the tree is the safest guide for this. I have seen the boles of trees thirty-five to forty years of age after being pruned healing at the rate of half-an-inch a year from each side of the wound, whereas trees in a less vigorous condition did not heal over one-fourth of an inch in a year. Therefore the health and vigour of the tree should be the guide, so as not to prune a branch from the bole of a tree if the timber at the wound will in any way deteriorate before it heals over. Rotten branches on the boles of trees should be pruned off before they are affected with rot at the base, in order that the wounds shall heal before decay takes place.

Great care should always be taken against over-pruning, as thereby trees are retarded in their development, and rendered very unsightly. Trees at the final course of pruning ought to be left with their heads varying from one-half to one third of the tree. Oak coppice has become so worthless that pruning it need not be discussed.

The History of a Railway Sleeper.

Travellers on the North-Western Railway during the past year must have noticed with surprise the vast number of sleepers collected at Delhi and Umballa for the Delhi-Kalka Railway, and have wondered from whence such quantities of light coloured timber have come. Sleepers, as is generally known, are laid cross-wise on the ballast of the railway line, and on them the rails are fastened; they are placed approximately three feet apart, so about 1,760 sleepers are required each running mile of line. The white wood of which sleepers are composed is not found in the plains, but comes from the hills many hundred miles away. In the vast forests of Garhwal, Sirmoor, and Jaunsar, the hill sides are thickly clad with deodar (*Cedrus deodara*) and chir (*Pinus longifolia*) from which sleepers are chiefly made; these regions are a country in which there is not 100 yards of level ground; where in places, thousands of young trees can be seen coming up as thick as corn in a field; and supply most of the timber used on railways, in roofs, doors, &c. Felling the trees, and sawing the logs, is done by professional sawyers during the dry season of the year from October to June; during the rains the forests are nearly impenetrable and little work is done. After being sawn, the sleepers are sent down the hill sides, which are cleared to allow of their easy descent! or down shoots specially prepared for the purpose; or down timber runs, which are planted slopes on which the sleepers slide, each succeeding one pushing that in front till it reaches the river side, at the bottom. These hill sides are of wonderful beauty

and wildness, but from their inaccessibility they are seldom visited except by the forest officers in whose charge they are. After reaching the river sides, chiefly those of the Jumna, the Tonse, and the Giri, they are thrown into the water and are carried on till they reach the valley of the Dun where the rivers debouch from the hills ; at Dhakpathar they are stopped by a boom placed across the river, and collected by their various owners. Before the sleepers are thrown into the rivers they are marked on the broad side close to the ends. Each owner has his mark registered in the Forest Office on payment of a fee, so on reaching Dhakpathar the sleepers are all claimed ; sleepers that have no mark become the property of Government, but broad arrows are used to mark those cut in Government forests ; three arrows denoting first class timber, two arrows and one denoting inferior qualities.

The boom is placed diagonally across the Jumna where the bed is rocky and deep on the western Sirmoor bank, and shallow on the eastern or Dun bank : it consist of two beams of deodar, 15 inches deep, 6 feet apart, in lengths of 10 feet, held together by sleepers placed crosswise and dove-tailed into the top, the whole being kept together by wire rope passing through rings fastened on the top and round the beams at the joints ; the wire ropes are strongly attached to the rock on the west side, while to keep the boom in position, wire rope guys are fastened from the east side. Below the boom are timber logs, also kept in position by wire ropes, the object of the logs being to allow the passage of rafts over them. The sleepers coming down the main stream on the western side are diverted on to the eastern side by the boom collected by the owners in the shallow waters on the east, and stacked on the river side.

The boom is put up annually about the 15th November, and taken to pieces about the 15th June when the Jumna floods begin. It has only been in existence about 5 years ; previous to which, sleepers were collected by the Maharajah of Sirmoor, and by a contractor who made a large fortune in a few years. As portions of the rivers Tonse and Jumna pass on one side through Sirmoor territory, a fair proportion of the dues collected by the Forest Department is paid to the Maharaja. The Forest Agency look after the sleepers for 10 miles above Dhakpathar, returning to the water any that get stranded on the river sides : they put up and maintain the boom ; and rescue any sleepers that get past the boom owing to floods or accidents ; for doing this, carriage dues are charged on each sleeper for the river passage ; collecting dues for the boom ; and salvage dues for any sleepers rescued. The dues are very small, but, as the number of sleepers and karis sent down exceeds thirty lakhs annually, of which about three lakhs come from Government forests, the total of proceeds amounts to a very considerable sum. A good deal of difficulty is experienced in maintaining the boom ; small floods and freshets come down the river after each fall of rain ; and in

April, when the snows begin to melt, sleepers constantly get under the boom ; at night also in cold frosty weather it is hard to keep the establishment up to their work. It is greatly to the credit of the Department that only about 1,500 out of 30 lakhs of pieces get past the boom, a proportion of about 1 in 2000.

Some of the sleepers come from near the source of the Jumna, 110 miles above Kalsi, where it enters the Dun. The river flows over a succession of rapids, with a fall of about 20 feet per mile, through some of the most beautiful scenery in the world. The tall peak of Jumnotri, the source of the Jumna, can be clearly seen clad in everlasting snow, on a fine day, from the plains at Saharanpur ; Gangotri, the source of the Ganges, being also seen on the eastern side, some 60 miles away. At Kalsi, where the Saharanpur-Chakrata road is carried over the Jumna by a fine suspension bridge, on the right bank is to be seen the Chhatr-Sila, or canopy stone, a monolith which is inscribed with the edicts of Asoka ; it is supposed to be an ancient boundary mark between China and Hindustan. The stone is a quartz boulder, 10 feet long, and of the same height, inscribed with letters on two sides, and figures of elephants, &c., on the others. The name is probably due to its having been once covered with a canopy, as there are a number of squared stones close to the rock which probably formed the pillars.

A short distance above the junction with the Jumna, the Tonse has a beautiful spot known as " the dripping wells ; " clear limpid spring waters filter through the rocks and fall in showers on the river banks, the surface of the rocks being covered with enormous fronds of maiden hair, (*Adiantum capillus-veneris*, (Linn)), that most graceful of ferns.

When sufficient sleepers are collected at Dhakpathar a raft is made. About 120 broad-gauge, or 160 narrow-gauge sleepers are put into each raft, two layers of sleepers, laid flat and cross-wise, forming the main portion, others laid longitudinally keeping them together. They are all tied with coarse grass rope, and a few sleepers are placed on the top to form a sort of hurricane deck, on which the men stand. The rafts are about 50 feet long, and guided by two men with long sal barge poles, who keep them in mid-stream and shove them off the sides when going down rapids and round curves in the river. After being put together the number of sleepers in the raft is counted by the forester, and a pass is supplied on which the number is entered ; they are checked at various places till the raft passes into the western Jumna canal at Bogriwalla, or down the river below the canal head.

A voyage down the river on a raft is as interesting and exciting an event as one down a Canadian river in a bark canoe manned by *voyageurs* ; and calls to mind the ludicrous adventures of Mark Twain's " Tramp Abroad " on the German timber raft on the Rhine. In the river broads all is quiet and plain

sailing; but where there are rapids, and in the narrow artificial channels made in places where the river is almost impassable, the passage is adventurous, and all the skill of the raftsmen is required to prevent the raft being dashed against the sides and broken up; the numerous broken and stranded rafts testify to the fact that the passage is none of the easiest, and the greatest care is necessary. One particular spot, about three miles above Rampur Mandi is the Scylla and Charybdis of the raftsmen. The Jumna here passes through a gorge where the depth of water is great, and the sides are rocky; a black conglomerate rock can be seen jutting into the main stream of the river, with a strong whirlpool above it; many rafts go to pieces at this point and the sleepers are sucked under water; the men believe that they never appear again but they probably are carried down a passage in the rock under water, and come to the surface again lower down stream. There is no doubt that the passage at this point is dangerous, and the place a fearful one.

Good sport is to be had from a raft going down the river; duck and teal abound on the river bank; and, accustomed to the sight of the rafts constantly passing, allow them to approach very close before rising; a very fair bag can be made in this way. A spotted or hog deer can often be shot in the early morning when taking his morning drink before retiring for the day to the sal forests of the Siwaliks; while leopards, and occasionally tigers, are to be seen at the water's edge. If only one of the uninteresting looking sleepers on a railway could speak, what splendid accounts could it not give of lovely scenery and wild animals it had seen on its passage from the hills to the plains of India.—(*Z*, in the *Pioneer*).

VII—TIMBER AND PRODUCE TRADE.

Churchill and Sim's Circular.

October, 5th 1892.

EAST INDIA TEAK.—We have again to report a wretched delivery of 661 loads for the month, against 1,551 loads in September, 1891 and 2,040, loads in September, 1890, making only 7,656 loads for the nine months of this year, against 11,392 loads in 1891 and 12,926 loads in 1890. Some business is reported at fair rates in floating cargoes, a few being now due in Europe and some of them unsold. In the meantime the London Dock Stock is reduced to very moderate dimensions and prices here are stationary.

ROSEWOOD.—EAST INDIA.—There is no improvement in the demand, and therefore, although stocks are not heavy, they are sufficient.

SATINWOOD.—*Logs*, if plain or of small sizes, are neglected, but for large and figury logs fair prices are obtainable; *planks* and *boards* are not in demand.

EBONY.—There is no improvement in the demand and stocks remain heavy.

Price Current.

Indian Teak	per load	£9 10	to	£15
Cedar, Malabar,	per sup. ft.	3d	to	3½d
Satinwood	per ton	£6	to	£10
Rosewood	per ton	£7	to	£10
Ebony	per ton (nominal)	£6	to	£9

MARKET RATES FOR PRODUCTS.

(*Tropical Agriculturist, October, 1892.*)

Cutch	per cwt.	24s.	to	34s.
Croton seeds	"	15s.	to	20s.
Gum Arabic, Madras	"	40s.	to	80s.
Gum Kino	"	80s.	to	90s.
India Rubber, Assam	per lb.	1s. 6d.	to	2s. 1d.
" Rangoon	"	1s. 6d.	to	1s. 9d.
Myrabolams, Bombay	per cwt.	9s.	to	10s. 6d.
" Jubbulpore	"	8s. 3d.	to	9s. 6d.
" Godavary	"	8s.	to	9s.
Nux Vomica, good	"	8s.	to	9s. 6d.
Orchella, Ceylon	"	20s.	to	25s.
Redwood,	per ton	£3.	to	£3-10s.
Sandal wood, logs	"	£35	to	£60
" chips	"	£9	to	£30
Sapanwood	"	£4	to	£7
Tamarinds	per cwt	8s.	to	9s.

Some of our readers may be interested to learn in the Introduction to the Annual Accounts of the Seaborne trade and Navigation of Bengal, 1891-92, it is stated that the exports of Myrabolams to the United Kingdom in that year almost doubled and that the average price was higher, being Rs. 4-4 per cwt against Rs. 3-6 in the previous year. The improvement may be set down to the smaller importations of Valonia. We hear that the falling off is caused by an insect which has recently committed great havoc among Valonia acorns.

VOL. XVIII]

[No. 12.

THE
INDIAN FORESTER;
A MONTHLY MAGAZINE
OF
FORESTRY,
AGRICULTURE, SHIKAR & TRAVEL.

EDITED BY

J. S. GAMBLE, M.A., F. L. S.,

CONSERVATOR OF FORESTS, AND DIRECTOR OF THE
FOREST SCHOOL, DEHRA DUN.

DECEMBER, 1892.

MUSSOORIE :

PRINTED BY THE MAFASILITE PRINTING WORKS
COMPANY, "LIMITED."

1892.

Contents.

No. 12—DECEMBER, 1892.

	Page.
I.—ORIGINAL ARTICLES AND TRANSLATIONS.—	
<i>The date sugar industry of Bengal, by Upendra Nath Kanjilal</i>	451
<i>Comparison between the Floras of the Eastern and Western Peninsulas of India, by Sir. D. Brandis (translated by C. G. R.)</i> ...	457
<i>The Forest Service of Netherlands India</i> ...	460
<i>Visit of Spanish Foresters to the French Reboisement Works (from the Révue des Eaux et Forêts)</i>	460
II.—CORRESPONDENCE.—	
<i>Fires caused by bamboo friction, letter from 'J. S. B,' 'F. J. B,' and 'W. J. L.—R.'</i> ...	462
<i>A Forest Blazer, letter from 'Taw Kway,'</i> ...	464
III.—OFFICIAL PAPERS AND INTELLIGENCE.	
<i>Note on the Potato disease in the Poona District</i> ...	465
<i>Pass marks at the Forest School Entrance Examination</i>	469
<i>Travelling Allowance of Foresters</i>	469
IV.—REVIEWS.	
<i>Botanical and Afforestation Department of Hong-kong in 1892.</i>	470
<i>The Madras Forest Report of 1890-91.</i>	471
V.—SHIKAR.—	
<i>Extraordinary Capture of Wild Elephants, by H. B. Bryant</i>	472
<i>Dehra Dún Camp of Exercise</i>	473
VI.—EXTRACTS, NOTES AND QUERIES.—	
<i>A new method of preserving potatoes</i> ...	474
<i>Barré and the discovery of the Cocco-de-mer</i> ...	474
<i>Pruning in Parks and Gardens</i>	477
<i>New appointment of Col. Bailey, R. E.</i> ...	479
<i>Wood Concrete</i>	480
VII.—TIMBER AND PRODUCE TRADE.—	
<i>Selling rates of timber in the N.-W. Provinces on September 30th, 1892.</i>	481
<i>Churchill and Sim's Circular, November 5th, 1892.</i>	482
<i>Market rates for products</i>	482
VIII.—EXTRACTS FROM OFFICIAL GAZETTES.	

SUPPLEMENT.

APPENDIX SERIES OF THE INDIAN FORESTER.

Report on the Sea-borne Trade in the Timbers of Burmah.

THE
INDIAN FORESTER.

Vol. XVIII.] December, 1892. [No 12.

The Date Sugar Industry of Bengal.

Unlike most other palms, the date palm (*Phoenix sylvestris*) has a very wide distribution, being indigenous in many parts of India. It forms extensive forests in Rohilkhand, on the low ground along the Ramganga, on the Mysore plateau between Shimoga and Tumkur, in the forest lands of the Gwalior State, on the outskirts of villages in most parts of the Central Provinces, and is not uncommon along the outer Himalaya, extending westward up to Jammu, and attaining an altitude of 5,000 ft. in Kumaon. It also occurs plentifully, self sown and uncared for, along the Eastern Coast, where it is occasionally tapped by a certain class of people, chiefly for toddy. But it is in Central Bengal that is it most extensively cultivated, and its usefulness as a sugar-yielding tree fully utilized. It is with a hope of attracting to it, some of the attention which it so well deserves, that I write this article, giving as much of the details of the working as the limits of a paper in the *Indian Forester* will permit.

The manufacture of sugar from the sap of this palm is a highly lucrative industry in Central Bengal comprising the districts of Jessore, Khulna, Faridpur, Backerganj, with portions of Pabna, Nuddea, and the 24 Pargánas; and it is not wholly unknown in the districts of Hugli and Howrah, and also in Northern and Eastern Bengal. The total area under its cultivation may be estimated at 150 square miles, that in the Jessore District alone being about 30 square miles (Hunter's Imperial Gazetteer, Vol. VII. page 187.)

Cultivation.—Although of an eminently accommodating nature, the date palm affects humid alluvial soils, and a moist climate. It is extremely sensitive to shade, and avoids clay soils and water logging. It is cultivated in the following manner in Bengal.

The ripe seeds, collected in May, are sown in a nursery during the rains. The nursery is kept clear of grass and weeds and in the third rainy season the seedlings are transplanted 9' × 9' into

the garden which has been previously hoed up or ploughed. This gives about 200 trees per Bengal beegha, or 585 trees to the acre. When 5 years old, the green upper leaves are tied up like a bouquet, the lower yellow coloured ones being cut away with a sharp knife. At the seventh year, the woody stem appears about a foot and half above the ground, when the tree becomes fit to be tapped. But for the health and long life of the tree it is advisable to wait until the eighth or ninth year when the stem rises about 3 feet above ground, the cutting away of old leaves being meanwhile repeated every year, and the garden kept well ploughed throughout.

The ground need not be exclusively left to the date trees. While they are young, several pulses (*Phaseolus radiatus*, *Cajanus indicus*, &c.) are raised under them, and when they become about 30 years old, the crowns being then elevated and much contracted, even paddy can be grown under them.

Tapping Operation.—The usual apparatus required for this work consists of (1) a rope (Fig. 3 a) 9 ft. long and 1 inch to $1\frac{1}{2}$ ins. through, which is tied loosely round the operator and the tree, and by means of which a practised man can climb up the tree almost as fast as he can walk on the ground; (2) a bag or cylindrical pouch (Fig. 1 a) transversely oval, about a foot deep and $6'' \times 4''$ at the mouth, made of hide or plaited palmyra-leaf in which are carried the *daws*, spouts and other articles and to which are attached a wooden-hook (Fig 1 b) and two loops of string (Fig 1 c) the loops going round the waist of the man and being tied in a knot in the front, and the hook suspending an earthen pot (Fig. 1 d); (3) a piece of leather (Fig. 3 b) $1\frac{1}{2}' \times 1'$ which is tied on the back of the man along with the pouch, and which protects his person from the rubbing action of the climbing rope;—and (4) three *daws* (billhooks) one heavy and two lighter ones, all being shaped like fig. 2.

The tapping is a delicate operation commenced in October and done in several stages. First of all with the heavy *daws*, all the old leaves are cut off from below the crown, and all the leaves from one side of it leaving only a few at the top, the bases of the petioles and the sheaths being carefully removed. (Fig. 3) Then with the lighter *daws* the outer zone of loose soft tissue is pared off in long slices, leaving only a thin covering of it over the sap—supplying inner zone, which corresponds to the woody zone in the older wood of all palms. Very great care should be taken not to expose this inner tissue at this stage, otherwise the tree is sure to rot and die, as often happens when the operation is entrusted to inexperienced hands. The experts at this work are called *Suilis* or *Gachis*.

After the first operation, the trees are given about eight days' rest, by which time the fine covering of soft tissue gets a little hardened and begins to crack. The second operation consists in removing this covering, great care being taken not to cut

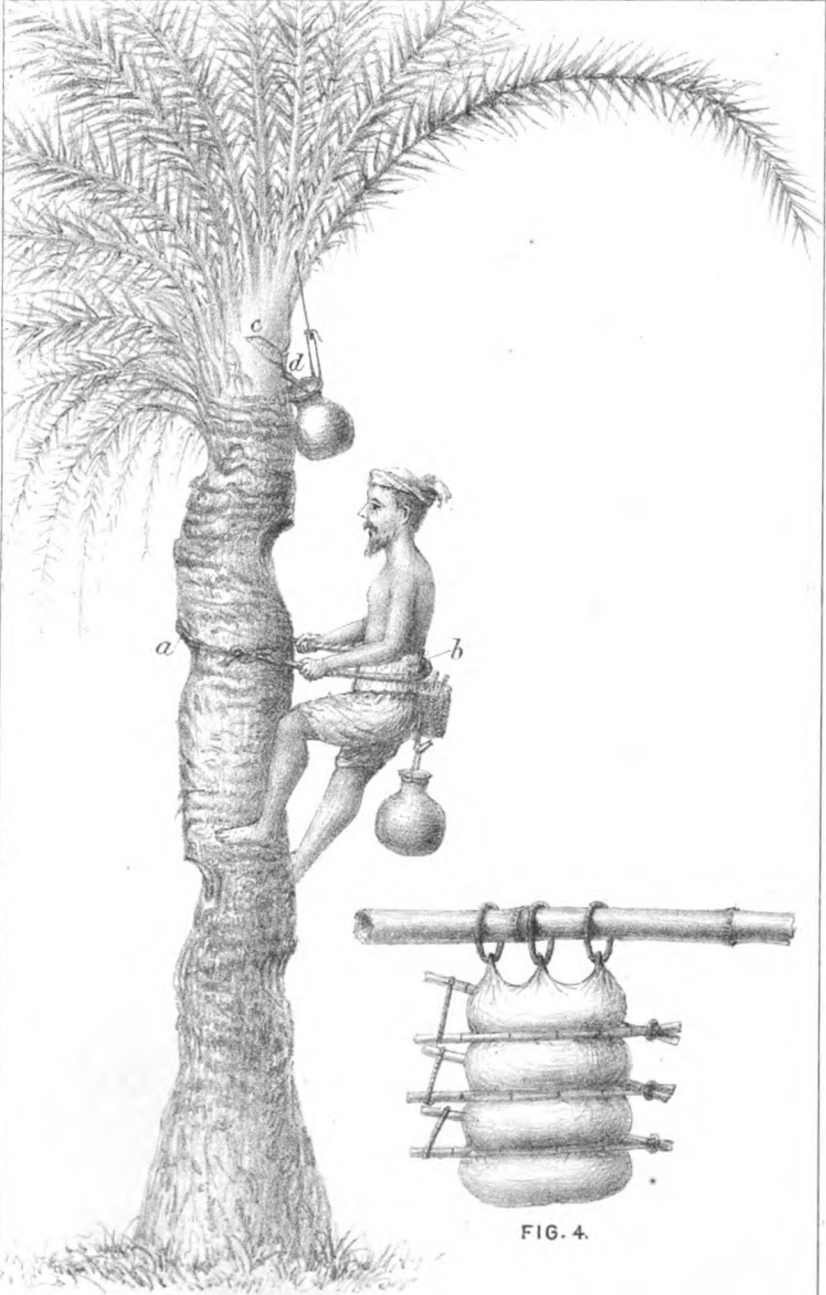

FIG. 3.

FIG. 4.

into the inner zone, which is now for the first time simply exposed. While at this, the Siuli may cut a few more of the upper leaves, leaving however a convenient one over the centre of the blaze, from the petiole of which the pot will afterwards be suspended.

Then comes a rest of twelve days or two weeks which brings us to the beginning of November. The Siuli then begins what he calls *nolen-rom* (*i. e.* fixing the spout). At the outset he divides his trees into 7 convenient groups, each group consisting of 50 to 60 trees, the number which can be operated upon in one day,—300 to 400 being the total number which one man can manage, constituting what is called a *mahál*. A large farmer may have several *maháls* each under a Siuli. The *nolen-rom* consists in cutting two eye-shaped notches 3 to 4 inches long and about a quarter of an inch deep at the base, their lower sides being straight and converging to a point (See Fig. 3 c.) below which a split bamboo switch (Fig. 3 d.) by way of a spout is gently thrust in, making an angle of about 45 degrees with the tree. If the tree is a healthy one, the sap should now be seen moistening the cuts, and trickling down the spout. The Siuli then suspends the pot which he carries from one of the upper leaves, the spout coming into it, and its mouth resting against the tree. The pots are emptied early next morning. Sometimes, to make the pot more steady, the Siuli catches hold of a leaf from the opposite side of the tree, splits it at the end, pulls the two ends on to the neck of the pot from right and left, and ties them together in a knot there. If he wants to prevent birds from perching on the pot, which some of them, allured by the sap, are very fond of doing, he cuts the end of a leaf and inserts it into the mouth of the pot, covering spout and all. If a tree is low enough to be within reach of jackals, a similar precaution is taken; but instead of the ends, the lower portions of leaves are used, the strong spinescent leaflets effectually keeping them off. In the case of weakly trees which do not give out much sap at the first cutting, the pot is not put up until the week after. The first two or three week's sap is very valuable, for the *gúr* produced from it, called *nolen-gúr*, has a pleasant smell and is much appreciated by the consumers.

After a week, the cut is renewed a little, the froth and dirt accumulated on the first cut carefully removed, and the pot again hung up. In some parts the cut is made on three consecutive days. This gives a much greater quantity of sap, but the trees become weakened, and the quality of the *gúr* is much inferior, being mostly uncrystallizable molasses. In this case, the rest given is not a week but only four days. Each day's sap has a name given to it, being respectively *Jiren* (rest), *Dokát* (second cut), and *Te-kát* (third cut). They are never mixed together but boiled into *gúr* separately, the *Te-kát* producing hardly anything but molasses. Under the one-week system, the pot may be put

up, without renewing the cut; to collect what is called *ola* (trickling) This is boiled separately into molasses. The sap collected during the day time under the other system is also called *ola*. In any case, the cut is renewed week after week until about the middle of March, by which time a very deep notch is made into the tree nearly reaching its centre. The next year's cut is made on the opposite side of the tree but at a higher level, the tree having grown in height in the meantime. This, continued year after year, gives the tree its characteristic zigzag appearance.

The yield of sap is greatest in mid-winter. The sap collected in calm and cloudless nights gives *gúr* of the best quality. In January, when the trees begin to put forth their inflorescence, the sap becomes very poor in sugar, though profuse in quantity, and as a rule does not produce good crystals. The average yield of a tree is about 10 seers a day. It becomes less and less after the trees are about 20 years old, but the sap becomes almost proportionately richer in saccharine matter.

The earthen pots in which the sap is collected require some care. They have to be well smoked every morning as soon as emptied. This gives them a glazed surface; also the alkaline salts of the smoke neutralize acidity, and the heat kills any ferments that may have been produced. If this were neglected, the ferments would eat up all saccharine matter, and the sap would become a toddy.

The *daws* also require to be closely looked to. They are sharpened several times a day on a batten of dry wood—preferably of Kúl (*Zizyphus Jujuba*)—sprinkled over with fine sand while the *daws* are new, but with dry potter's clay afterwards. They may even require tempering once or twice during the season. Special care is given to the tip (Fig 2 a): if too sharp and pointed it cuts into the tree and thus injures it, sometimes fatally; and if too blunt, it tears the tissues and clogs the pores at the base of the cut, with the serious result of turning the sap acid and frothy.

Boiling.—For this purpose a peculiar sort of furnace is made; a shallow rectangular pit is dug in the ground, over which a low dome of mud is built, supported on a framework of bamboo while the mud is soft. Into this dome, circular holes 15 to 18 inches in diameter are cut in two rows along the length of the rectangle, the number varying according to requirements, from 4 to 14; and two flues are made at the short ends. On each of the circular holes is placed a conical (more properly semi-elliptical) thimble-shaped Earthen vessel capable of containing from 30 to 60 lbs of sap. Usually an umbrageous tree is utilized for its grateful shade; in default of it a temporary shed of date leaves supported on bamboo posts is erected over the furnace.

The fuel supply is a point of some interest. Towards the Sunderbands, Sundri wood (*Heritiera littoralis*) is generally used, but elsewhere the cost would be prohibitive. Dried up date

FIG. 1.

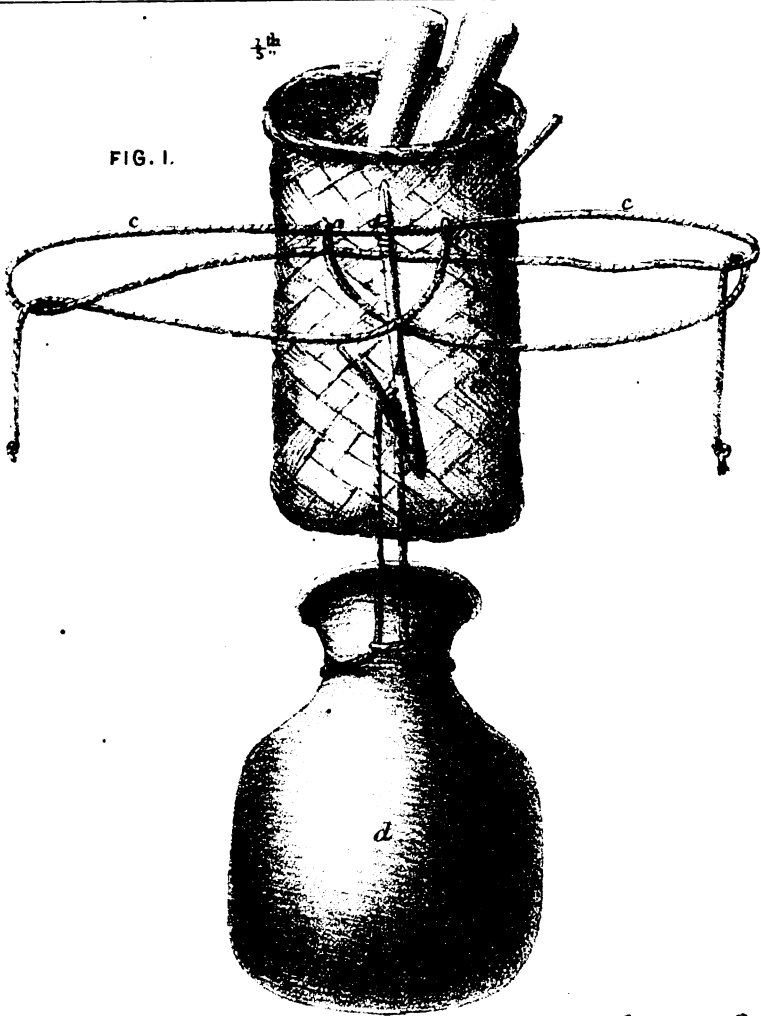
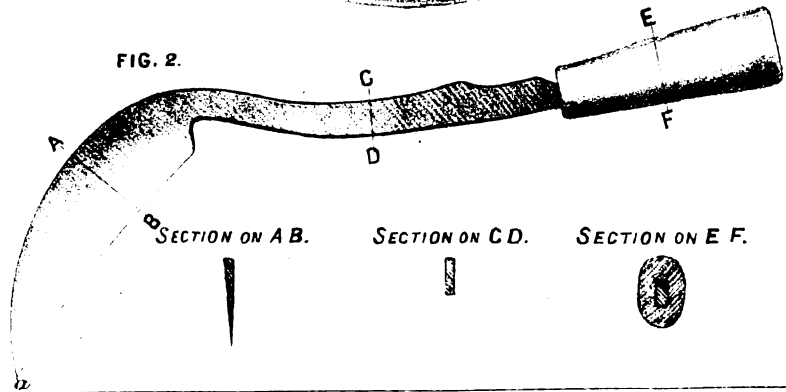

FIG. 2.



leaves, those which, as mentioned above, are cut in October, are utilized as far as they go, but they do not go very far. A few farmers living along the Railway lines have of late years (since the opening of the Jubilee Bridge at Hugli) begun to import coal from Raniganj, but this is not possible for people living in the interior. The main supply then comes from the village coppices. This sounds strange, but certain areas in every village in Lower Bengal, mostly around homesteads and under mango and other trees, are perpetually treated as coppice on one year's rotation, without anybody even so much as dreaming of the sylvicultural system which they practise. The species so treated are Ghentu (*Clerodendron infortunatum*), Ans-Seoru (*Glycosmis pentaphylla*), Bâkas (*Adhatoda vasica*), Se-kûl (*Zizyphus Enoplia*), and such other shrubs. The *gur* manufacturers get these for a mere song, as the proprietors are only too glad to have their jungle cleared free of cost every year.

The boiling once started continues day after day, the Siuli operating on a fresh group of trees every day. As soon as the furnace is well ablaze, a thick white froth appears on the surface which should be promptly removed. For this purpose a ladle, called *Urki*, made of a cocoa-nut shell with a bamboo-stick as handle, is used. The date palm sap, however, is remarkably free from feculent matter and therefore requires less skimming than the cane or any other kind of sugar-yielding saps. It has, on the other hand, a slightly larger proportion of gluten, and therefore gives a smaller outturn of sugar crystals. After about an hour's boiling, the sap is said to be *Sarisa-phuli* (like mustard flower) from the fact of its turning golden yellow and giving out in quick succession small round bubbles which resemble the petals of the mustard flower. Soon after this, big isolated bubbles rise slowly with a dull explosive noise, and the peculiar smell of *gur* is noticed. The *gur* is now ready, and must be promptly poured into earthen jars or other vessels in which it will be taken to market for sale. If too little done, the *gur* is liable to become acid after a few months, and the crystals small; if too much done, it suffers in colour and flavour and may even become bitter and sticky, and therefore uncrystallizable. It is therefore very important that the boiling be stopped at the right time. The crystals form when the *gur* cools. The outturn of *gur* is from 1-10th to 1-8th of the quantity of sap. It is estimated that an average tree yields about half a maund (41 lbs.) of *gur* per year.

The next point is sugar-making. I will notice this but briefly. As a rule the cultivator himself does not do it on a large scale. He sells his *gur* to the sugar manufacturer who is usually a well to do sweetmeat-maker. The *gur* is put into gunny bags, which are then hung up on poles, and pressed tight, each by means of three pairs of bamboo levers, as shewn in Fig 4. The molasses trickles down leaving the brown crystals in the bags. The raw sugar is then thrown either into baskets or into

earthen tubs, called *nads*, with perforations underneath. It is then lightly sprinkled over with water, and covered by a layer of *pata* (*Vallisneria spiralis*), two inches thick. This is an aquatic plant found growing luxuriantly at the bottom of stagnant pools of water, such as *beels* and old tanks; and even of rivers with little or no current, of which there are so many in Bengal (e. g. the Kapatuk, the Chitra, the Betna, the Bhairab, the Kana-Nadi, the Kana-Damodar and others). The attenuated cellular tissue of this plant has the property of absorbing moisture at every point to a remarkable extent, and the result is that after a week, the brown crystals to a depth of about 2 inches become tolerably white and glistening. This upper layer is then removed and sun-dried, and the process repeated with the remainder. The molasses collected in this manufacture is boiled down in large pans into a black sticky treacle which is an indispensable ingredient in the tobacco for the native hookah and has therefore an extensive sale all over India. The date palm treacle supplies at any rate the whole of Bengal.

I give below an estimate of the probable expenditure on and income from an acre of this kind of plantation.

EXPENDITURE.

Preparing nursery, sowing, and transplanting one acre of garden, once for all	Rs.	12	0	0	
For the first eight years annually, Interest on Rs. 12 @ 25 per cent per annum (the usual rate of village money-lenders in Bengal)	Rs.	3	0	0	
Rent (for half year, that for the other half being debitable to pulses, &c.)	"	4	0	0	
Ploughing twice a year	"	1	0	0	
Weeding and cutting leaves	"	1	0	0	
			9	0	0
This repeated every year and with compound interest @ 25 per cent will after the 8th year amount Rs. 179 say	Rs.	180	0	0	
After the first eight years, annually.—					
Interest on Rs. 180, @ 25 per cent	Rs.	45	0	0	
1½ Siulis @ Rs. 5, for 5½ months	"	41	0	0	
1 Assistant @ Rs. 3, do.	"	17	0	0	
Pots, vessels, &c.	"	27	0	0	
Daws and gear	"	10	0	0	
Fuel	"	50	0	0	
Carting the <i>gür</i> to market	"	10	0	0	
Contingencies	"	15	0	0	
	Total Rs.	215	0	0	

INCOME.

Number of trees tapped daily = $\frac{585}{7} = 83$

Quantity of sap collected daily @ 10 seers a tree = 830 seers.

Outturn in *gür* (1-10th the quantity of sap) ... = 85 ,, or say 2 Mds.

Total quantity of *gür* for the whole season of 135 days (from 1st November to 15th March

= 135×2

= 270 Mds.

The selling rate is from Rs. 2-8 to 3-8 per Md.

Taking the lowest rate we get ... Rs. 675

Deducting the total Annual Expenditure of Rs. 215 we get a net profit of Rs. 460 per annum per acre.

The average sap-yielding life of a tree may be taken as 20 years, after which period the trees, if sold even as fuel, will fetch at least the capital outlay of Rs. 188.

It will be seen from the above figures that a poor family of the cultivator class, who contrive to live on an annual income of Rs. 60 or so, can live comfortably on the proceeds of a hundred trees, if they are only taught how to go about the business; for the net profit per tree per annum may very safely be put down at a rupee and this may undoubtedly be exceeded in the vicinity of forests where fuel is plentiful and cheap, and if indigenous trees are utilized.

I think it will be interesting to know if the Agricultural Department has up to date made any attempt to introduce this industry where it is yet unknown, and the result of such attempt. Forest Officers, especially those in charge of forests where this useful tree is indigenous, will no doubt take great interest in such information, and will, with the greatest pleasure, co-operate with the sister department as far as lies in their power.

UPENDRANATH KANJILAL.

COMPARISON BETWEEN THE

Floras of the Eastern and Western peninsulas of India.

BY SIR D. BRANDIS (TRANSLATED BY C. G. R.)

Sir D. Brandis communicated a paper in which he discussed the principal differences between the flora of India proper and that of further India. Both peninsulas enjoy a similar rainfall and the same conditions as regards the amount of moisture in the air. They differ however in some essential matters. The flora of the peninsula of India proper, agrees most closely with that of tropical Africa, while that of further India approaches that of the Malay Archipelago. That several genera which are represented by a considerable number of species in Africa, exist in India proper, and have nearly or entirely disappeared from further India, proves the correctness of this statement. As an example, we may mention the genus *Cleome*, natural order *Cupparidaceæ*. 22 species of this genus are found in tropical Africa, 12 in India proper, while only one, *Cleome viscosa*, a common widespread tropical weed, is found in further India. *Maerua*, which in Africa is typically a limited genus with 17 species, has in India proper only 2 species, *Niebuhrria (Maerua) linearis* and *Maerua arenaria*, and is not found in further India.

Cadaba has 6 species in tropical Africa, four in India proper, and none in further India. Among the *Meliaceæ*, 6 species of the

genus *Turrea* are known in Africa, 2 in India. *Cochlospermum Gossypium*, a small tree with large golden flowers, of the natural order *Bixaceae*, which is characteristic of the dry areas in India proper, is not found in further India, but 3 species of this genus are indigenous in tropical Africa.

A second essential difference exists in the configuration of the land. In both peninsulas, mountains rise to a height of 7,800 feet. The mountains of India proper are separated from the Himalayan Mountain Range by the vast plains watered by the Indus and Ganges and their tributaries. In further India, on the contrary, the large rivers of the Irrawaddy, Salween and their tributaries flow essentially from North to South, the mountains which separate the valleys, in which these rivers flow, from each other, and from the Bay of Bengal, stretch in the same direction, joining the Eastern ranges of mountains as far as China, with the continuation of the Himalaya, to which they themselves are united at their Northern ends.

The fact that several genera and species which are found in the Himalaya, and in the mountains of China, are represented in further India, and are absent from India proper, is traceable to this arrangement of the mountain Ranges.

It may be advisable to illustrate this statement by reference to the genera *Acer*, *Æsculus*, the natural order *Cupuliferæ* and the genus *Pinus*. The genus *Acer* contains, even when one accepts a mean of the recorded number of species, 60 or 70 separate individuals, and of these 39 species grow in the Eastern parts of Asia, *i. e.* in the Himalaya, and Japan. These regions form the centre of its distribution and in them the greatest variety of forms is exhibited. If we exclude the states bordering on the Mediterranean Sea, the Maple is not found in Africa, and it is also absent from the whole of the peninsula of India proper, although one or two species thrive well in the gardens of the Nilgiris. Of the 14 East Indian species, 12 belong to the Himalayan Range of mountains; while 2 only are found in Burma (*A. isolobum*, (Kurz) and *A. niveum*, (Blume) the last named being also indigenous in Sumatra. *Acer oblongum*, (Wall.) and *lævigatum*, (Wall.) extend far South into Burmah, the former down to the tropics, the latter to the 16th degree North Lat.

Eleven species of the genus *Æsculus* are known, of these 6 belong to the new, and 5 to the old world. Of the latter *Æ Hippocastanum* is indigenous to the Mountains of Greece, *Æ indica* to the North West Himalaya, while *Æsculus Pundwana* extends from the Eastern Himalaya through the peninsula of further India to Siam. Two species, *Æsculus chinensis* and *turbinata* have their home in China and Japan. In the hills of the peninsula of India proper and also in Africa the genus is unknown.

(1) Dr. Pax (Engler, Jahrb. VII p. 177 XI p. 72) records 85 species.

The natural order of the *Cupuliferae* is very markedly developed in the Himalaya, China and Japan, and all the Indian genera *Betula*, *Alnus*, *Quercus* (in its widest meaning), *Castanopsis* and *Carpinus* are represented in further India, the oaks numerously so. In India proper, however, and in Africa, excluding the provinces bordering on the Mediterranean Sea, this Natural Order is not found.

Five species of the genus *Pinus* are known in the East Indies. *P. excelsa* and *Gerardiana* belong to the North West Himalaya; *Pinus longifolia* grows on the spurs and in the valleys of the outer ranges of the Himalaya from Afghanistan to Bhootan; *Pinus Kasya* forms a pure forest on all the high hills of further India, above 2,600 ft.; and *Pinus Merkusii* is found in conjunction with *Dipterocarpus* in the Thoungeen and other localities in further India about the 16th degree N. L.; it is also found in Sumatra and Java. In India proper and in Africa except near the Mediterranean Sea, the genus *Pinus* is absent. Besides the above mentioned genera, there are still several which are found in the Himalaya and further India, which are not found in India proper or Africa. Among these a few genera indigenous to the Himalaya are found in the mountains of tropical Africa, which are absent both from India proper and from further India; of these the genus *Juniperus* is worthy of notice.

Juniperus procera grows on the mountains of Abyssinia and is found on those of Kilimandjaro in tropical Africa. Four species of *Juniperus* are indigenous in the Himalaya. An intelligible distribution is not wanting in the genera which are found in India proper and further India and which are absent in Africa except in the Provinces bordering on the Mediterranean Sea. Take, for example, *Euonymus*: of the 27 Indian species, 6 are found in India proper, 3 in Ceylon, 11 in the Himalaya and 7 in further India. As another example: Teak, (*Tectona grandis*), forms a great portion of the forests in both peninsulas while in the dry portions of further India, a second species, *Tectona Hamiltoniana*, is found. The genus *Tectona* is not found in Africa.

In conclusion, it must be mentioned that the saying "nulla regula sine exceptione" holds good. There are some tropical species which are found in further India and Africa and are wanting in India proper. We may mention two genera of trees and shrubs belonging to the family *Connaraceae* as a proof of this. Three species of the genus *Agelaea* are found in tropical Africa, 2 in further India, and 4 other species in Madagascar. *Cnestis* has 7 species in tropical Africa, and one (*C. ramiflora*) grows in further India, Sumatra and the Philippine Islands.

C. G. R.

The Forest Service of Netherlands India.

We have been favoured with an account of the classes and grades of the Forest Service in Java and Madura, by the kindness of one of the Conservators.

It is a little difficult to translate florins into rupees, but we have thought it best to go by the silver value. As the rupee contains, 372 oz. Troy and the florin 328 oz., we may say that the florin is nearly equivalent to 88 rupee. Taking this rate, the classification and rates of pay are as follows:—

Upper Service.—for which the diploma of a European Forest School is required :

	<i>Pay about.</i>	<i>Traag. All. about.</i>	per day.
Inspector General of Forests	Rs. 1,050 to 1,500	Rs. 8	12
Houtvester (Conservator) 1st class	„ 660 to 1,000	„ 7	4
„ „ 2nd „	„ 400 to 700	„ 7	4
„ „ 3rd „	„ 300 to 460	„ 5	4
Aspirant Houtvester (Dy. Consr.)	„ 220 to 400	„ 5	4
Technisch ambtenaar (Asst. Cons.)	„ 130 to 300	„ 5	4

Lower Service.—for which the diploma of any Indian School is required.

Bosch-opriener 1st class	Rs. 132 to 176	Rs. 44	fixed all.
„ 2nd „	„ 88 to 132	„	
„ 3rd „	„ 110 to 154	„	
Tijdelijk opriener	„ 66 to 110	„	

Native Service.

Mantrie-politie	} (Forest Guards)	Rs. 44	
Boschwachter		„ 13-4	none.

Visit of Spanish Foresters to the French ' reboisement ' Works.

All the nations of Europe follow with a marked interest the progress of the huge work which France has undertaken with a view to the restoration of mountain lands. For some ten years, studies relative to this subject have been made in the French Alps by deputations which have been sent from Austria, Russia, England, Switzerland, Italy, and now Spain. Visitors follow each other in rapid succession, work with ardour and all depart satisfied and pleased with what they have seen.

Fire
making
(bamboo)

Type spec.

Phrenobor
Acad.

Atly, the Spanish Government wished to complete the
f its young Foresters by a practical exercise bearing on
tion of torrents. The field of their explorations was
France in the Basses-Alpes. The deputation which has
France consisted of Don Miquel del Campo, Ingeniéro
de montes, professor of sylviculture at the College of the Escorial,
and of seven students of that college who in a few weeks are to
pass out into the active service. The deputation arrived on the
evening of the 15th July at Barcelonnette, where M. Demontzey,
Forest Administrator, was at the time on tour. That high
functionary, assisted by M. Carrière, Conservator of Forests at Aix,
and all the local Forest Officers, directed the studies of the de-
putation on the ground.

Four days were given to excursions in the area under restora-
tion in the Ubaye valley. In this area were visited, on the 16th,
the torrents of the Bourget and Faucon ; on the 17th, the torrents
of Gaudrisart and Riou-Chanal ; on the 18th, the torrent of Riou
Bourdoux ; on the 19th, the torrents of the Bourget and the
Sanières.

On the 20th, the deputation left Barcelonnette for Spain.—
(From the *Révue des Eaux et Forêts*).

II.—CORRESPONDENCE.

Fires caused by Bamboo Friction (No 1.)

In reply to S. E. W. on Fires caused by Bamboo Friction,
I write to say that I have seen the Koyas of the Bhadrachellam
Taluk, Godavari District, light a fire by rubbing two pieces of
dry bamboo together. But the bamboo was not *in the round* ;
before the man could produce the fire he had to *prepare* the
bamboo, and the following sketches clearly show how the thing
is done.

A bamboo is slit in two, in one piece a slit (A. B. in Fig I) is
made about 1-3rd of an inch wide and with the sharp edge of the
second piece a man rubs over the slit A. B. as hard as he can.
(Fig. II.) A fine wood powder is produced which in a very short
time ignites.

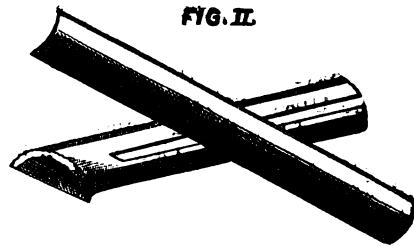
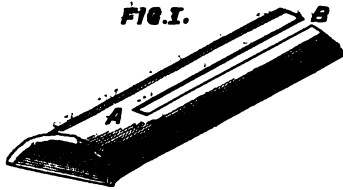

The edges of the slit and of the piece used to rub with must be sharp, and both pieces of bamboo must be firmly held. That fires can be produced by the rubbing of two pieces of bamboo *in the round* I consider an impossibility, and so did that Koya before we parted.

J. S. B.

FIRES CAUSED BY BAMBOO FRICTION (No. 2.)

The Honorary Editor, in the October issue of the 'Forester,' appends a foot note to the article under the above heading asking for any authentic instance of fire caused by friction of bamboos.

I have now and again seen fire obtained by Burmans, Karens and Shans in this manner, but I cannot possibly do better than extract bodily from Mason's 'Burma' Vol. II. what he says on the subject.

"Among other uses to which the bamboo is applied in 'Burma, not the least useful is that of producing fire by friction. For this purpose a joint of thoroughly dry bamboo is selected, '1½" or 2" in diameter, and this joint is then split in halves. A ball is now prepared by scraping off shavings from a perfectly dry bamboo, and this ball being placed on some firm support, as a fallen log or piece of rock, one of the above halves is held by its ends firmly down on it, so that the ball of soft fibre is pressed with some force against its inner or concave surface. Another

' man now takes a piece 1" long or less, and shaped with a blunt
' edge something like a paper knife and commences a sawing
' motion backwards and forwards across the horizontal piece
' of bamboo, and just over the spot where the ball of soft fibres is
' held. The motion is slow at first, and by degrees a groove is
' formed, which soon deepens, as the motion increases in quickness.
' Soon smoke arises, and the motion is now made as rapid as possi-
' ble, and by the time the bamboo is cut through, not only smoke,
' but sparks are seen which soon ignite the materials of which
' the ball beneath is composed. The first tender spark is now
' carefully blown, and when well alight the ball is withdrawn,
' and leaves and other inflammable materials heaped over it, and
' a fire secured.

In the appendix to the same work the following also occurs:—

" Another method of obtaining fire from bamboos is thus des-
' cribed by Capt. T. H. Lewin as practised in the Chittagong
' Hills. The Tipperahs make use of an ingenious device to obtain
' fire, they take a piece of dry bamboo, about a foot long, split in
' half and on its outer round surface cut a nick or notch, about $\frac{1}{4}$ "
' broad, circling round the semi-circumference of the bamboo,
' shallow towards the edges, but deepening in the centre until a
' minute slit of about a line in breadth pierces the inner surface
' of the bamboo fire stick. Then a flexible strip of bamboo is
' taken about $1\frac{1}{2}$ ' long and $\frac{1}{8}$ " in breadth to fit the circling notch
' or groove in the fire stick. This strip or band is rubbed with
' fine dry sand and then passed round the fire stick on which the
' operator stands, a foot on either end. Then the slip, grasped
' firmly, an end in each hand is pulled steadily back and forth,
' increasing gradually in pressure and velocity as the smoke
' comes. By the time the fire band snaps with the friction, there
' ought to appear through the slit in the fire stick some incandes-
' cent dust, and this placed, smouldering as it is, in a nest of dry
' bamboo shavings, can be gently blown into a flame. "*Hill
' Tracts of Chittagong and the dwellers therein*"—p. 83.

I have never seen this last method practised, but, as I have
said above, the former method is well known in Burma.

F. J. B.

FIRES CAUSED BY BAMBOO FRICTION (No. 3).

SIR,

In your last issue you call for authentic cases of where fire
has been obtained by means of friction and as a case once came
under my personal observation, I send you details as to how the
fire was obtained.

During 1890 I was stationed at Htigyaing in Upper Burma and while returning home from an afternoon ride with a friend we got caught in a shower of rain and were obliged to take shelter in a Zyat (Burmese rest house) on entering which, we found two Burmans engaged in obtaining fire out of two pieces of bamboo by rubbing one against the other. One of the Burmans asked me for a match, but I would not give him one, as I wished to see him obtain the fire from the stick, and told him to continue the operation. The materials employed were two pieces of split, dry, bamboo obtained from the roof of the Zyat. One piece (A) had a small slit cut in it transversely at the top about $\frac{1}{4}$ inch deep so as to just go through it, the edge of the piece (B) being so shaped as to exactly fit this slit.

Fig. I.



Longitudinal Section of A

Fig. II.



Transverse Section of B

Fig. III



A and B in position.

One of the men then scraped both the convex and concave sides of the split piece (A) with a knife and obtained some fine shavings which he placed in the concave side of the piece (A) just under the slit. The second man now fitted the piece (B) into the incision as shewn in Fig. III and began to pass it rapidly backwards along the incision and in about five minutes obtained fire with which he lighted his cigar.

I tried the operation myself with fresh tinder and also obtained fire.

W. J. L.—R.

A Forest Blazer.

SIR,

Having been away on leave, I have only just seen the August Number of the *Forester* in which I see "Velleda" proposes a tree as a badge for the Forest Blazer. Why not take the hunting horn as our badge, the badge (a hunting horn) on the Nancy Forest Blazer is very neat and effective, besides being good heraldry, as the horn has been connected with Foresters in song and story from time immemorial.

"TAW KWAY."

III.—OFFICIAL PAPERS & INTELLIGENCE.

Note on the Potato Disease in the Poona District.

In January last year a potato disease was brought to notice affecting the crop of the Khed and Junnar Talukas, which largely supply the Poona and Bombay markets. It has since been found elsewhere in the Poona District, in the Gujarát, and at Mahabaleshwar. It seems to have made its first appearance some three or four years ago, and it now occupies the chief potato grounds of the Presidency, causing heavy loss to cultivators and a marked deterioration of quality in the potatoes sold for consumption.

The cultivators call this the "bāngdi" disease, owing to the appearance of a dark ring, easily visible in the substance of the tuber on section. Unsound and (apparently) sound potatoes are found in the same field; but the whole crop is, in such cases, probably affected. The first *outward* symptom is a withering of the green top, with arrests of the growth of the tuber. The diseased crop, when dug, is found to be greatly undersized throughout, many tubers are rotten and putrid; others show, by a small livid spot, where putrescence is about to set in. The whole potatoes are eatable when fresh, but rot away in storage.

2. During the past season, potatoes were imported from Mahabaleshwar, Saharanpur, Bangalore, Ootacamund* and England, and were distributed to cultivators as seed, in the hope that the sets from hardy stocks and from a distant soil might prove sufficiently robust to resist the infection, at least for some years. Mr. Mollison, the Superintendent of Farms, gave special attention to this experiment and also tried the effect of applying solutions of sulphate of iron and of sulphate of copper to the affected fields. Both experiments have failed. The worst plots were naturally those sown with the Mahabaleshwar seed, it not having been known before that the hill district was already infected. The only sound crops found were those grown in the compound of the Mámlatdár's office at Khed and in a garden hitherto used for "pán" (*Piper betle*). Neither of these two grounds had been under potato for some years certainly. All the other crops exhibited the characteristic ring.

3. Concurrently with these experiments, a field was sown at the Khandesh Government farm with Poona seed which appeared to be perfectly sound. Some of the seed potatoes were kept for further examination. Khandesh is not a potato district, and the land sown had never been under potato before. The crop was diseased throughout, proving that the seed was infected, though

when sown, the signs of disease were not distinguishable by the eye. On examination of the seed-potatoes which had been stored, the characteristic ring and a mottled unhealthy condition of the flesh were plainly apparent. Mr. Mollison found in the diseased crop indications of a fungus which appeared to attack the green stem first.

4. At the Poona farm, four varieties of English potatoes received from Messrs. Sutton and Sons, were planted side by side with Poona potatoes, selected for apparent soundness, on land not before used for this crop. The English seed of all varieties produced a sound and healthy crop and has been reserved as seed for further experiment. The local potatoes were diseased, but not greatly so, and were marketable. In this experiment all the potatoes were planted in ridge-rows as in England; the irrigation water being directed along the furrows.

5. A small quantity of true seed (from inflorescence) was obtained from France and was also tried at this farm. The object of growing from the true seed is to establish a strong and natural stock, such as in Europe is systematically resorted to when the artificial strains have shown a tendency to weakness. This experiment is being continued, but conclusions cannot be drawn at this early stage.

6. Specimens of plants in various stages of sickness, have been submitted by Mr. Mollison to Dr. Cunningham, the Special Assistant to the Sanitary Commissioner with the Government of India, who has undertaken a scientific investigation of the blight. I have Dr. Cunningham's permission to quote his provisional conclusions, but it must be clearly understood that the subject is still under enquiry by him, as well as by this department, and that any opinions expressed are subject to modification after a more complete investigation. Dr. Cunningham writes:—
 "You are quite right in distinguishing this affection from 'common potato blight; for there are no signs of phytophthora about the plants. So far as I can ascertain, it is essentially due to an invasion of the vascular bundles of the base of the haulm by fungal mycelium, which is to be found in all the elements of the bundles, and in special abundance in the larger vessels, which are in many places absolutely plugged by dense sclerotical masses of filaments. With such an invasion of the water-leading system, it is of course only natural that withering of the host should occur. The method of irrigation which you say is employed must afford special facilities of access to the parasite invading the submerged basis of the haulms, and the continuous cultivation of crops from year to year in the same areas must tend to keep up a continuous supply of the parasite, the sclerotical masses of mycelium within the vessels being very well adapted to survive prolonged periods of dormancy with a capacity for renewed active growth on the recurrence of favourable conditions."

7. Mr. Mollison drew attention to the fact that the disease shows itself only on the plant approaching maturity, when the

fibro-vascular bundles of the stem are well developed. At first the flesh of the tuber shows little or no sign of disturbance, but at a point about an inch below the soil-surface, a brown stain makes its appearance in the substance of the haulm, and, this extending above and below, the disease rapidly declares itself. The sudden wilting of the apparently healthy green plant, often within 24 hours, is a marked and peculiar symptom. In a further communication, Dr. Cunningham says :—“None of the specimens ‘of the blight which I have seen show any trace of spore formation ‘but they do most distinctly show the formation of sclerotical ‘masses of mycelium within cavities of the vessels. These are ‘probably the source of propagation, as similar bodies certainly are ‘in the case of some vegetable blights ; and if so, the delay in ‘the appearance of the disease is readily accounted for, as ‘sclerotia frequently require a considerable time to become ‘roused from their dormant condition and give origin to new ‘mycelium. They, in fact, play the part of resting spores, and, ‘like them, are not always at once prepared to germinate. The ‘brownish tinge in the vascular bundles is in the haulm clearly ‘associated with the invasion of the mycelium..... It is, as ‘you suggest, very probable that it is only in the upper layers of ‘soil that the sclerotia find all the conditions favouring their ‘becoming active. There appears to be little tendency to spread ‘of the mycelium downwards along the bundles of the roots, as ‘compared to that which it has to pass upwards along those of the ‘haulm, and I have as yet been unable to find any traces of it in ‘the tubers, even where most highly affected as indicated by the ‘blackening of the vascular bundles and surrounding areas of ‘parenchyma.”

8. The scientific enquiry, Dr. Cunningham goes on to say, can only be concluded by means of experiments on infection of living plants, and these cannot be carried out before next cold weather. Meanwhile, every effort must be made to discover a practical remedy for a disease which threatens to destroy one of the most valuable garden crops of the country. So far it has been shown :—

(i). That the disease is not the European potato-blight. From this it differs in the absence of the black fungus spots on the leaves and of the characteristic odour ; and it differs also in not being amenable, when the crop is in the ground, to treatment by the sulphate of iron and copper solutions.

(ii). That diagnostic symptoms may be found before the characteristic ring in the tuber is apparent, in the sudden wilting of the green top, and in the antecedent brown discoloration of the fibro-vascular bundles of the haulm, discoverable on section.

(iii). That the disease-germ harbours in the soil, and will infect all stocks however robust.

9. The origin of the pest is probably to be found in exhaustion of the soil and of the stock owing to over cultivation. The crop is so profitable that it is grown year after year on the same land, and the unwillingness of the cultivator to exchange it for less valuable produce, even when disease is rife, forms one of the chief difficulties to be met. A rest from potato for three or four years would probably cleanse infected land.

10. This note is published in the hope that, attention being drawn to the subject, other investigators may assist in the enquiry, so that repressive measures may be introduced without loss of time. The further experiments to be made by this department next season will be carried out mainly on the following lines ; but others will doubtless suggest themselves :—

(i). By application of the solutions of iron and copper to the field *before sowing*. Dr. Cunningham's researches have afforded a clue to the failure of this method when applied to the growing crop. Used in this way, it succeeds with the ordinary blight, and in the absence of microscopical investigation it was puzzling to find that it had absolutely no effect on this disease. But, as the fungus is found to establish itself at once in the deep tissues, it is clear that external applications to the plant can be of no use. The fungal germs can, however, be attacked while harbouring in the soil, and a free treatment with the solutions ought to succeed. If in infected soil, so treated, and sown with healthy seed, an untainted crop can be produced, a considerable step in advance will have been made.

(ii) By improved cultivation. The method adopted at the Poona Farm, of growing the potatoes on ridges as in Europe promises to afford considerable protection. There is little doubt that a saturated surface soil is favourable to the disease and this it gets in perfection by the native method of growing potatoes on the flat. Mr. Mollison placed his ridges about 24 inches apart, with a foot between sets, and, the irrigation water being run in the furrows, the soil was kept continuously moist without ever being in the condition of a quagmire as under the native system of flooding. The potatoes so grown were of fine quality and flavour and free from the waxiness common to the Indian grown tuber. This, and the fact that none of the Indian potatoes produce seed-plums, looks as if a faulty method of cultivation may have caused degeneration and consequent susceptibility to disease in all the acclimatized stocks. The ridge system, in any case, deserves to be fully tried.

11. I append a few instructions as to the solutions referred to in the preceding paragraph.

E. L. CAPPEL,

Director, Land Records and Agriculture,

Poona, 11th June, 1892.

Bombay.

Cooper Sulphate solution with quicklime ("Bouillie Bordelaise") for 1 acre :—

- 46 lbs. sulphate of copper.
- 22½ lbs. quicklime.
- 220 gallons of water (2,200 lbs.)

The sulphate should be dissolved by hanging it in a coarse cloth or basket in water contained in a wooden vessel. Hot water acts more quickly. The quicklime is slaked in a separate tank and then stirred into a fine gruel with added water. This should be passed through a sieve into the solution, well stirred, and the remaining water added.

Iron solution with quicklime is made in the same proportions, substituting the iron for the copper salt. It is much cheaper, but its value has not been definitely proved. The "Bouillie Bordelaise" was proved to be specific for the European blight by an exhaustive series of experiments in England and on the Continent, and the recipe is given as published by the Royal Agricultural Society. As the quantities were intended for spray application to the plant surface, probably more will be required for the disinfection of the soil, and a double quantity of the copper solution might be tried; in the case of the iron solution even more may probably be applied without danger to the crop.

Pass-Marks at the Forest School Entrance Examination.

The following order of the Inspector-General of Forests, issued with the approval of the Board of Control of the Forest School, may interest some of our readers.

In supersession of previous orders, the pass-marks to be obtained in each of the subjects of the School entrance-examination in the English course will in future be as follows :—

(1) English	{ Conversation	50 per cent.
	{ Composition	33 ditto.
(2) Arithmetic, all branches	40 ditto.
(3) Algebra, up to Quadratic Equations	40 ditto.
(4) Elementary Plane Geometry	25 ditto.
(5) Mensuration (lengths, areas, volumes)	25 ditto.

Travelling Allowance of Foresters.

A recent Resolution of the Government of India authorizes the grant by Local Governments to Foresters not in charge of Ranges, of Travelling Allowance at the ordinary rates, when their duties necessitate the keep of a horse or pony or the maintenance of other carriage. We suppose this will also meet Delta's complaint (July No., p. 253) and that those Foresters who are in charge of Ranges will now get the usual allowance in the C. P. as elsewhere.

IV.—REVIEWS.

Botanical and Afforestation Department of Hongkong.

We have received the annual report of the Botanic Gardens of Hongkong for 1891. Three pages out of seven are occupied with correspondence on the true origin of Chinese Ginger: some years ago the British Consul at Swatow started the idea that preserved ginger was furnished by the plant called *Alpinia Galanga*, Willd. whereas the investigations of Messrs Groom and Ford have conclusively proved that *Zingiber officinale* Linn. is the true source of preserved ginger as we know it, the mistake having arisen from the resemblance of the Chinese names, Leung Keung for the produce of *Alpinia*, and Yuk Keung for the true ginger.

Part of the duty of the Superintendent is to grow plants which are lent for decorative purposes when public entertainments are given, and a careful record is kept of the number supplied on loan; it does not appear that any damage is done to these.

Under Forestry, we have plantations in which 115,081 trees were put out, chiefly *Pinus sinensis*, and natural seedlings and shoots springing up wherever protection is assured, but the want of water renders the work more and more difficult every year.

The following remarks on grass fires will be read with interest:—

“The year has been one of the greatest immunity from fires which has been known. Only 10 fires are recorded, and most of them were confined to the destruction of grass only. Fires which occurred within plantations were confined to very small areas, only 700 trees having been destroyed. There were 64 fires and 107,000 trees destroyed in 1890. The great immunity from fires was due to vegetation being less dry at the seasons of ancestral grave worshipping in spring and autumn when, as a rule, fire has hitherto been very carelessly handled at the graves scattered over the hills; and also, in all probability, partly owing to the exercise of more care in the use of fire in consequence of worshippers having been impressed with the importance of the prevention of fires.”

‘Old fire barriers to the extent of 26 miles were cleared, and, 20 miles of new ones made during the months of August, September and October, the work being completed by the commencement of the dry season, during which all destructive fires arise. Every year gives evidence of the usefulness of these fire barriers in arresting the spread of fires.’

'The unburnt remains of trees destroyed by fire in 1890 were all removed and sold as quickly as possible in order to prevent the inhabitants gaining any advantage by their being able to remove them for their own uses.

Thinnings are carried on in the plantations whenever the trees are too crowded and 59,000 pines were thus removed during the year, and sold for 601 dollars, the total revenue being a little more than this. The expenditure of the department is not stated.

The Madras Report of 1890-91.

In our May number we briefly reviewed the Madras Forest Administration Report for 1890-91. We have now received the orders of the Government of India on it. In these orders we see it laid down that "there are doubtless zones where, chiefly for climatic reasons, no natural fruits grow, but mere sterility should not as a rule be held to be a bar to the formation of reserves or to the fostering of the growth, which of itself eventually may create a more fertile soil." This is no doubt, sound, if not very clear; the district referred to is Chingleput, which like all the Carnatic country has tracts of laterite uplands and occasional more or less stony hills which are usually covered with scrub of a sort largely intermixed with prickly pear. If let alone, this scrub grows excellently, and there can be but little doubt but that in Chingleput, and indeed in all parts of the Madras Presidency, natural forests did grow at one time, for we find their unmistakable remains everywhere, and know that even centuries of hacking and goat grazing have not entirely destroyed them.

The Government of India and that of Madras do not seem entirely to agree on the question of special fire-protective measures in forests likely to be thrown open to grazing, for while the former consider such measures unnecessary, the latter think that "partial protection of tracts open to grazing may have a considerable effect in preventing wanton firing and limiting accidental fires." We are entirely with the Madras Government in this and would go further: there are good reasons why grazing areas should be protected; one is because fires most undoubtedly destroy the finer succulent grasses and foster the strong hard, nearly inedible kinds; another, because there is rarely such a wide line of natural demarcation between areas grazed and areas not grazed so that if fires are allowed in the one they naturally spread to the other unless expensive measures are taken. Every Forester knows that, bar incendiarism, it is just as easy and as cheap to protect a large tract of well defined boundary as a series of small ones. The rule should be that, which we think the Madras authorities maintain;—no fires allowed in any areas under

protection, but specially expensive protective measures only in the more valuable Reserves.

There is not much else to notice in the papers received, except the approval of the Government of India of the system of growing trees, with agricultural crops exemplified in Tinnevely with the Umbrella tree, *Acacia planifrons*. We should be glad if some of our Madras subscribers would tell us something about this, for we are not quite clear what it is that is being done.

V.-SHIKAR, &C.

Extraordinary Capture of Wild Elephants.

An interesting and extraordinary capture of wild elephants by the "Pit system" took place on the Anaimalai Hills in the Government Reserved Forest on the night of the 22nd instant.

It was only on the 17th instant that I arrived at the Mountstuart Camp and gave directions that the elephant pits used last year should be prepared for further captures. On Monday the 19th, six pits were completed and duly covered, ready for the animals to fall into. It was on this day that the Conservator of Forests, Mr. Cherry, arrived at Mountstuart to continue his inspection of the South Coimbatne District. The Pits are arranged in groups of three within a quarter of a mile apart.

Three nights passed off without a fall having occurred. On Thursday night, however, the 22nd instant, about 8 P. M., frantic cries of elephants were heard coming from the locality in which the pits were situated, and we at once thought that a fall must have taken place. I proceeded at once to the pits, after having given directions for the tame elephants, and ropes, &c., to be brought, and taking with me all the Mulcers (i.e. hillmen) who happened to be in the neighbourhood of the Camp.

After driving away the herd of elephants which was hanging around, we approached the three pits to which we had been directed by the cries of the animals, and discovered that an extraordinary fall had taken place. Into two of the pits single animals had fallen, and into the third a Cow with a calf had fallen; thus, four elephants had fallen into the three pits. I immediately sent word to the Conservator who soon joined us at the pits, and in the meantime the Ranger and some more subordinates with the tame elephants had arrived.

We set to work to take the animals from the pits and transfer them to the kraals, but the two animals in the same pit gave a great deal of trouble, and it was not until 6-30 a. m. on the 23rd morning that we succeeded in getting them out of the

pit. The young one kept close beneath its mother and consequently it was difficult to noose it. The old cow was very much exhausted and lay down several times on the way to the kraals; however, she was eventually taken to them all right as also the calf, and the tame elephants were then brought back to extract the other two. The latter gave very little trouble, and by 7 p. m. of the 23rd, they also had been put safely into the kraals; thus, within 24 hours after the fall, all four animals had been transferred from the pits to the kraals. All the elephants with the exception of the big Cow seem to be doing well. Their sizes are as follows:—

1	Cow elephant height 8 feet.
1	Male calf " 4 "
1	Smaller Cow " 6½ "
1	Still smaller Cow " 5 "

P. S.—Since writing the above, another fall has taken place which renders the capture still more interesting. It was only on the 23rd instant at about 7 p. m. that the first four elephants were taken out. There then only remained three pits ready for the animals to fall into. At six o'clock on the morning of the 25th, I heard cries again coming from the pits and proceeded to the spot and found three more elephants, a young one in one of the pits and two big ones in another, whilst the third remained untouched. The animals were safely removed to the kraals by 4 p. m. the same day.

H. B. BRYANT.

Dehra Dun Camp of Exercise.

The following were the prizes won by Forest School Officers and Students at the Camp of Exercise of the Mounted Rifles in the Dún.

Shooting, 200 and 300 yards	...	Corpl. Rivett, 3rd.
" , 300 and 600 "	...	Sergt. Lane-Ryan 2nd.
Capt. Armstrong's Cup, 2nd prize	..	Trooper Ryan.
Reserve Company Shooting, 3rd prize		A. F. Gradon.
Chart and Compass Race, 2nd prize		Trooper Jackson.
Section competition, 2nd prize	...	Sergt. Allen.
do.	4th	" Pierce.
Postilion Race,	1st	" .. Sergt. Lane-Ryan.
Lime cutting,	1st	" .. do.
Boot and Saddle Race,	1st	" .. do.
do.	2nd	" .. Sergt. Allen.
Tent Pegging,	1st	" .. Sergt. Lane-Ryan.
Victoria Cross Race,	1st	" .. Trooper Tweedie.
Tug of War,		... Forest School Team.
Col. Harington's Cup for best sportsman	...	Sergt. Lane-Ryan.

VI.—EXTRACTS.

New method of Preserving Potatoes.

The Society for the encouragement of national industry in France, has recently awarded a prize of one thousand francs to a Mr. Schribaux for a method of preserving potatoes which he has invented. It is well known that in the spring when the young shoots or sprouts of the potato develop, the tuber gives up its reserve material, begins to deteriorate, and soon becomes unfit for consumption. Various methods have been devised, with more or less success, to prevent this, most of them being founded on the principle of keeping out the air.

Mr. Schribaux' method forms quite a new departure, in that he kills the buds without injuring the tubers. His method consists in immersing the potatoes in a sulphuric acid bath for a period of 12 to 15 hours; they are then taken out, thoroughly dried and stored. Small depressions are seen in place of the "eyes" which have been completely destroyed, but the skin of the tuber remains smooth and sound.

The strength of the both should be two parts of the sulphuric acid of commerce to one hundred of water, and it will serve over and over again; moreover the solution is so weak that it can be handled with impunity, and placed in any sort of vessel.

Some potatoes treated on this method were examined in September, when they had been nine or ten months out of the ground and it was found that they had the same composition and the same nutritive value as in the previous May, the only difference being that they had lost a little moisture.

(*Révue Agricole of the Mauritius.*)

A. S.

Barre and the discovery of the Coco-de-mer.

Visitors to Kew Gardens who have lately watched with interest the highly curious—indeed, most remarkable—germination and growth, in the warm Lily-tank house, of the once mysterious Coco-de-mer, may be pleased to learn the particulars of its original discovery in the Seychelles Islands; whence it is now named the *Lodoicea seychellarum*.

This group of small islands, some 5 degrees south of the equator, and 55 degrees east of Greenwich, is supposed to have been first discovered, as far as Europeans were concerned, by the Portuguese, early in the sixteenth century, possibly in 1506, by Fernando Suarez, and named The Seven Brothers. It was not, however, until 1742, that the enterprising Governor of the Isle of France, Labourdonnais, sent Captain Lazare Picault in the *tartane* "Elizabeth" to take possession of these apparently unimportant islands; and they were subsequently visited and settled by M. Moreau de Seychelles, one of the chief officers of the French East India Company, after whom they were named—the French Minister at that time being also his relative, the Viscount Hérault de Seychelles. In 1750, a Governor was appointed to Mahé, the principal island, under the control of the Governor of the Isle of France.

It is, however, to that skilful and observant engineer officer, Monsieur Barré, that we owe the first exact and detailed survey of the various islands composing this archipelago of twenty-nine islands and islets in the year 1769, which he undertook, by the special desire of that brave navigator, Captain Marion de Fresne, who was massacred with two boats' crews at the Bay of Islands, in New Zealand, during June, 1772.

Second in importance to Mahé, and 21 miles north-east of it, is the island of Praslin, with an area of some 27 square miles. It was here that Barré landed one fine morning for the purpose of surveying the coast of the island, which, from the number of conspicuous cocoa-nut trees was then named the Ile de Palme. Wandering outside the thickets and scrub, along the coral beach, he saw before him a huge fruit, which he at once conjectured must be a Coco-de-mer; but as it was just on high water mark, he thought it had been washed up by the sea, and not being acquainted with the size or shape of Coco-de-mer, of which he had only heard by reputation, or only seen when nuts without their enveloping husk, he was not at all sure that it was one. However, knowing the rarity and costly value of a unique specimen (which, up to that date, had been sold in the markets throughout India and China in small pieces for its weight in silver), he carefully concealed the fruit, which weighed at least 50 lb., out of sight, until he could transport it safely to his ship. But on leaving the shore, rather priding himself on his lucky discovery of a prize, what was his surprise and indeed mortification to find the ground under the tall Palm trees covered with numbers of these nuts in all stages of germination, whilst looking up at the mighty Palms above him he saw that these fine trees bore the same fruit. He had discovered the true habitat of the wonderful tree heretofore unknown to science: a tree so wonderful that General Gordon, more than a hundred years afterwards, declared that is must have sprung from the tree of knowledge which originally grew in Eden in pre-Adamite times.

No wonder that at first sight the poor engineer, who had thought to fill his purse with fifty pounds of silver in exchange for his Coco-de-mer, felt some vexation,* foreseeing that as soon as the wonder-working fruit, which was supposed to be the product of the sea, became recognised as a terrestrial natural object, its fictitious value in the oriental markets would speedily become a thing of the past; and rightly he judged, for the Coco-de-mer is now only of value as a botanical curiosity.

He found these magnificent double Coco Palms to elevate their crests to a height of at least 50 (French) feet; their summits to be crowned with a tuft, or huge plume, of about a dozen fronds, each 20 feet in length, and somewhat in the form of a fan; and each of these great leaves to be supported on a stipe 6 feet long, which is hollow or indented (*échancré*) in its contour. From the axilla (*aisselle*) of the leaves, issues a panicle, with the branches which bear the female blossoms. The pistil of these flowers he found to produce at maturity the huge fruit which, with its husk, weighed, as before observed, some fifty pounds.

On reflection, and after careful examination of this large grove (Rochon calls it a forest), Barré was persuaded that this Coco Palm was not the real Coco-de-mer of commerce—not the true sea-borne double Coco-nut, whose recuperative qualities were so highly esteemed by the enervated Moguls of India. Nevertheless, out of sheer curiosity, he collected some three dozen of the nuts, and took them with him to the Isle of France, where the celebrated botanist, M. Pierre Poivre, instantly recognised them as the true fruit so much sought after; and as M. Poivre was at this time the Intendant and Commissary of Marine of the French Colony, he and the Governor, the Chevalier Des Roches, instantly accelerated the departure of Captain Grenier,† who, assisted by Rochon, was about to sail for India, with instructions to visit the Isle de Palme, or Praslin as it was now named, and obtain some germinating nuts and young plants for the Government Botanical Gardens then being formed at Pamplemousses and at Le Reduit.

Accordingly, on May 30, 1769, the "Heure du Berger" and the "Verd-Galand," commanded by Captain Grenier and Lieutenant Law Fontaine respectively, left Port Louisa; and on June 2, the day of the transit of Venus, these ships were off the Vigie bank, reaching the Seychelles on the 13th of the same month. Rochon speaks feelingly of the danger he encountered in journeying to and fro from the ship to his observatory on shore. Crocodiles! sharks and torpedos, we are assured, did great damage, and several of his men were bitten or wounded by these animals. We cannot help thinking that the torpedos were less dangerous than the spikes of the mud-laffs! However, Alexis Rochon duly

* "Il vit avec peine," says Rochon, "que la terre étoit couverte de ces fruits et des arbres qui les portoient." (*Voyages aux Indes Orientales*, p. 148).

† It was this Capitaine Grenier who discovered the short sea route to India for sailing vessels during the North—East Monsoon.

visited the Isle de Palme, and industriously collected a quantity of the young plants and nuts of the great Coco trees, the Cocos-de-mer, which he classified as a species of *Latania*. Filled with zeal, he transported several specimens, as well for the Museum of Natural History of Paris, as well as a young growing tree 20 feet in length.

Now comes the curious part of the story, which may be given in Rochon's own terms:—"On my return to Europe, I brought to the Academician, Louis Guillaume Lemonnier (brother of the astronomer), the doctor, a fine Cocos-de-mer (for so it is called), which had germinated in my trunk by the heat of the hold. The young shoot was doubtless arrested, for it ceased to grow in spite of all the care which this scientific botanist took to restore its life. The form of this fruit and of its germ contributed not a little to the celebrity of this Nut, designated by botanists under the denomination of *Nux medica*; the Indians regard it not only as a powerful antidote and counter-poison, but also as an excellent remedy for venereal diseases."

It is curious that Pickering gives no account of this discovery in his *Chronological History of Plants*; although he mentions the double nuts of the *Lodoicea seychellarum* as having been found by Hieronimo di Santo Stefano on the Maldiv Islands in 1496. He wrongly states that this *Cocos maldivica* was first ascertained by Sonnerat to be a native of the Seychelles Islands. *S. Pasfield Oliver, Captain, late Royal Artillery*,—(*Gardener's Chronicle*).

Pruning in Parks and Gardens.

In the afternoon a lecture was delivered by Mr. Thiselton-Dyer on the "Management of Trees in Parks and Gardens," and in commencing, the lecturer observed that he might venture to say, the subject he was about to speak upon did not receive so much attention in this country as it used to do, but he believed that if more attention be not given to it, we shall fail to hand down to our successors such fine specimens of ornamental and other timber as our ancestors left for us. Mr. Dyer said that it was a mistaken notion that the best trees are obtained by isolated planting, and said that the finest examples of timber trees in the country had been secured rather from judicious thinning than from the system just referred to, and instanced some of the woods at Kew, which they had evidence to prove had been planted thickly, and then successively thinned out, as being far superior to some planted at a later date, when our Royal family had less time to cultivate their timber, on account of the ill health of the sovereign. The finest trees could only be obtained by thick planting, and the consequent extensive sacrifice of less desirable timber. Mr. Dyer

thought that height was the first point to be obtained in an ideal tree. The axis should be kept entire, a well-balanced bole should be secured, and the branches should not be too long, for if such be the case it is probable that damage will be sustained through the effect of wind or snow. The worst possible form is that which he might describe as the Cabbage-headed tree. It is nothing but a gigantic bush, and the vast majority of trees are prone to this habit; but there are several influences that tend to create the Cabbage-headed growth, and the principal one was the loss of the leader. When a tree is planted in the open, it is exposed to all the cold winds, &c., and the result of a really hard winter or spring is that the leader is killed, after which it can only be restored by artificial treatment.

Pollards, the lecturer said, bore evidence that they had been tended until they had developed an unusually large bole before cutting for fire-wood. Forking was not quite so bad a form as the Cabbage-head, but still, a forked tree was extremely liable to be split by the force of wind playing upon one-half of the tree, and after that had taken place, and an opening had been made for disease and decay, they will not last any great length of time.

In pruning young trees (and all trees need looking to in this respect), steps must be taken to prevent excessive growth of the lateral branches. If the laterals are shortened, the leaders are strengthened to the same extent, and the lateral branches never appear to assume the habit they had of unduly extending themselves. Staking had its drawbacks as well as its advantages, and Mr. Dyer said that he had lately found that Mr. Waterer, by pruning the lateral growths has been able to dispense with any kind of staking. His own experience, however, did not quite justify such a step. But even after a tree has been staked, the necessity will still exist for pruning, and if the head is allowed to become unduly large, it is liable to be broken off. In fact, it will require more pruning than if it were not staked at all. Mr. Dyer then referred to the attacks of animals and cattle that trees were subjected to, and said that the French, who make their trees an especial study, recommended that the trees be painted with coal-tar. The lecturer had seen road metal placed around the trees to prevent cattle injuring them; they dislike to stand upon it or walk across it.

In regard to the preservation of old trees, the lecturer gave a detailed description of the bark with which the trunk of a tree is covered, and of the vital importance it was to the tree that the bark should be not injured or abraded, and declared that even in this matter timber trees were almost universally neglected. Mr. Dyer then gave directions as to the covering of any place that had become denuded of bark, recommending that the place should be scraped, and the whole then painted with coal-tar. This, the lecturer said was better than anything that becomes hard, and it never

gets quite set, thus allowing the gradual closing up of the healthy tissues, and the closure of the wound to go on. It also acts as an antiseptic. Mr. Dyer then said that branches, when cut off, should be cut close to the trunk, for that if a piece of the shoulder were left, it would decay, and disease would enter the tree, and its end sooner or later would be assured. If the branch is cut off in the manner advised, the bark will gradually close over and cover the cut. The lecturer then spoke of several species of fungi that attack trees, and gave directions for preventing the mischief arising from them.

Sir Trevor Lawrence, who occupied the chair, spoke of the Beech trees in some parts of Surrey that were dying off in hundreds, and, as they were planted upon the chalk, he presumed that they had exhausted the humus contained in the small quantity of soil they had got; but some of the cases could not be accounted for in that way, and he would like to show them to the lecturer, that he might give his opinion as to what was the cause of their death.—(*Gardener's Chronicle*).

New Appointment of Colonel Bailey, R. E.

The following extracts may interest our readers.

THE ROYAL SCOTTISH GEOGRAPHICAL SOCIETY.—At a meeting of the Council of the Royal Scottish Geographical Society held yesterday afternoon, Lieutenant-Colonel Bailey, R. E., was unanimously appointed Secretary in succession to Mr. Silva White. Lieutenant-Colonel Bailey is Lecturer on Forestry in the University of Edinburgh, and was for several years a Conservator of Forests under the Government of India. He also organised the Central Forest School in India. There were in all 42 applications.

THE anniversary dinner of the Royal Scottish Geographical Society was held last night in the Waterloo Rooms, Edinburgh. The chair was occupied by the Marquis of Lorne. The croupiers were Mr. A. L. Bruce, the hon. Treasurer of the Society, and Mr. J. G. Bartholomew, the hon. Secretary; and the company present included Professor Geikie, Dr. John Murray, Mr. Silva White (who recently retired from the Secretaryship of the Society), Colonel Bailey, R. E. (the new Secretary).

Sir R. MURDOCH SMITH proposed.—“ Our new Secretary,” and said, while the feeling of regret which they all entertained at Mr. Silva White's retirement must remain unabated, any feeling of trepidation as to the future that they might have had,

must not only have been greatly alleviated, but entirely removed by the good fortune which had befallen the Society in securing the services of Colonel Bailey. (Applause.) Giving an outline of Colonel Bailey's career, Sir R. R. Murdoch Smith mentioned specially that for many years he had engaged in the conservation of the great forests of India, and in the organising and supervising of special forestry officers for that branch of the public service.

Lieutenant-Colonel Bailey, in responding, observed that the fact that his election was the result of a unanimous vote had been a source of great gratification and encouragement to him in undertaking his new duties, and he assured the members that his best efforts would be devoted to the affairs of the Society, so long and ably conducted by Mr. White. (Applause.)

Wood Concrete.

A new wood concrete, according to the *Bautechnische Zeitschrift*, has been invented in Germany. Shavings and planing mill chips, either of common or fancy goods, which may be stained before use, if desired, are mixed with cheese, or, rather, casein, calcined magnesium, limestone, glycerine, silicate of soda, and a little linseed oil and this queer mess is forced by hydraulic pressure into moulds, where it is allowed to harden. When dry, the composition is strong and solid, and can be sawn, planed, polished, and varnished. It is expected that it will be found useful as an "ornament" in the shape of panels, or as a covering for entire wall surfaces.—(*Timber Trades Journal*.)

VII-TIMBER AND PRODUCE TRADE.

Statement of average selling rates of timber and bamboos in Meerut, Cawnpore, Bulandshahr, Bareilly, and Moradabad for the quarter ending 30th June, 1892.

Description.	Timber Scantlings per score.		Bamboos per 100 score.		REMARKS.
	From	To	From	To	
MEERUT.	R. A. P.	R. A. P.	R. A. P.		
Sal 10' Tors (Poles) ...	8 0 0	18 0 0	
Sal & Sain, &c. Karris, 12' x 5" x 4" ...	25 0 0	40 0 0	
Sal bed posts, 7' x 2½" x 2½" ...	8 0 0	10 0 0	
Bamboos of 9' to 10' per 100 score	28 0 0	80 0 0	
CAWNPORE.					
Sal 10' Tors (Poles) ...	5 0 0	10 0 0	
Sal, Sain &c. Karris, 12' x 5" x 4" ...	7 0 0	10 0 0	
Sal bed posts, 7' x 2½" x 2½" ...	2 8 0	3 0 0	
Bamboos of 9' to 10' per 100 score	20 0 0	30 0 0	
BULANDSHAHR.					
Sal 10' Tors (Poles)	
Sal, Sain &c., Karris, 12' x 5" x 4"	
Sal bed posts, 7' x 2½" x 2½"	
Bamboos of 9' to 10', per 100 score	50 0 0	50 0 0	
BAREILLY.					
Sal 10' Tors (Poles) ...	5 0 0	10 0 0	
Sal Sain, &c. Karris, 12' x 5" x 4" ...	25 0 0	35 0 0	
			40 0 0	...	
	50 0 0	60 0 0	
Sal bed posts 7' x 2½" x 2½" ...	10 0 0	15 0 0	
Bamboos of 9' to 10', per 100 score	50 0 0	137 8 0	
MORADABA D.					
Sal 10' Tors (Poles) ...	20 0 0	25 0 0	
Sal, Sain, &c., Karris, 12' x 5" x 4" ...	30 0 0	50 0 0	
Sal bed posts, 7' x 2½" x 2½" ...	10 0 0	12 8 0	
Bamboos of 9' to 10', per 100 score	50 0 0	100 0 0	

Churchill and Sim's Circular.

November 5th, 1892.

EAST INDIA TEAK.—Small stocks, small deliveries and low, although improving prices continue to be the features of this trade. A very small addition to the demand would quickly and materially improve the position, but of that it is not easy at present to discover the promise. The deliveries have been, for October, 778 loads, against 929 and 1,574 respectively in the two preceding years; and for the first ten months 8,434 loads, against 12,321 and 14,500 respectively.

ROSEWOOD.—East India.—Sales are not easily effected as there is no activity in the demand.

SATINWOOD.—*Logs*, unless of good sizes and figury, rule low, s the demand is dull; *planks* and *boards* should not be shipped.

EBONY.—Stores are heavy and the demand dull.

Price Current.

Indian Teak	per load	£9 10	to	£15
Cedar, Malabar,	per sup. ft.	3d	to	3½d
Satinwood	per ton	£5	to	£10
Rosewood	per ton	£5	to	£9
Ebony	per ton (nominal)	£5	to	£8

MARKET RATES FOR PRODUCTS.

(Tropical Agriculturist, November, 1892.)

Cutch	per cwt.	20s.	to	32s.
Croton seeds	"	15s.	to	20s.
Gum Arabic, Madras	"	40s.	to	80s.
Gum Kino	"	90s.	to	100s.
India Rubber, Assam	per lb.	1s. 6d.	to	2s. 1d.
" Rangoon	"	1s. 5d.	to	1s. 9d.
Myrabolams, Bombay	per cwt.	9s.	to	10s. 6d.
" Jubbulpore	"	8s.	to	9s. 6d.
" Godavary	"	8s.	to	9s.
Tamarinds	per cwt	8s.	to	9s.
Nux Vomica, good	"	8s.	to	9s. 6d.
Orchella, Ceylon	"	20s.	to	25s.
Redwood,	per ton	£3.	to	£3 10s.
Sandal wood, logs	"	£35	to	£60
" chips	"	£9	to	£30
Sapanwood	"	£4	to	£7

VIII.—EXTRACTS FROM OFFICIAL GAZETTES.

I.—GAZETTE OF INDIA. —

30th November 1891.—No. 1286-F.—With reference to the Notification of this Department, No. 926-F., dated the 12th August last, Mr. J. Nisbet, officiating Conservator of Forests, 3rd grade, Upper Burma Circle, Burma, reverted to his substantive appointment of Deputy Conservator, 2nd grade, Burma, on 22nd November 1891, the date of return to duty from privilege leave of Mr. J. W. Oliver, Conservator, 3rd (officiating 1st) grade.

29th December 1891.—No. 1348 F.—With reference to paragraph 12 of the Circular Resolution of this Department, No. 30 F., dated the 29th instant, the following appointments and transfers of Forest Officers are made in the interests of the public service :—

Mr. E. E. Fernandez, late Deputy Director of the Forest School at Dehra Dun (on deputation to the Baroda State). to be a Deputy Conservator of the 1st grade in Assam (*seconded*)

Mr. J. T. Jellicoe, Deputy Conservator, 1st grade, Assam—to Burma.

Mr. J. C. McDonell, Deputy Conservator, 1st grade, Punjab (on deputation to Kashmir)—to the Central Provinces (*seconded*)

Mr. W. E. D'Arcy, Deputy Conservator, 3rd grade, Punjab—to Assam, as Deputy Conservator, 2nd grade, but to continue as Officiating Conservator of the Central Circle in the North-Western Provinces and Oudh.

Mr. E. G. Chester, Deputy Conservator, 3rd grade, Andamans—to Bengal, as Deputy Conservator, 2nd grade.

Mr. W. M. Green, Deputy Conservator, 3rd grade, Bengal—to Burma.

Mr. A. J. Mein, Deputy Conservator, 3rd grade, Assam (on furlough)—to the Punjab.

Mr. A. M. Reuther, Deputy Conservator, 4th grade, Punjab—to Assam.

Mr. E. A. Down, Deputy Conservator, 4th grade (sub. *pro tem*. 3rd grade), Punjab—to the North-Western Provinces and Oudh, as Deputy Conservator, 4th grade (officiating 3rd grade).

Mr. J. L. Pigot, Assistant Conservator, 1st grade (Deputy Conservator, 4th grade, sub. *pro tem*), Punjab—to the Central Provinces, as Deputy Conservator, 4th grade, but to continue as Assistant Inspector General of Forests and Superintendent of Working-Plans (*seconded*).

Mr. A. F. Gradon, Assistant Conservator, 2nd grade (officiating 1st grade), Central Provinces—to Burma, as Assistant Conservator, 1st grade, and officiating 4th grade Deputy Conservator, but to continue as Instructor at the Forest School (*seconded*)

Mr. J. E. Barrett, Assistant Conservator, 2nd grade, Punjab—to Assam, as Assistant Conservator, 1st grade.

Mr. C. P. Fisher, Assistant Conservator, 2nd grade, Assam—to the Punjab.

2.—MADRAS GAZETTE :—

26th November Leave.—The twenty days' privilege leave granted to V. P. Ramalingam Pillai, Ranger, First Class, Nilgiri District, from 3rd November 1891, is approved and sanctioned.

4th December 1891.—No. 537.—The appointments of Messrs. E. P. Popert, J. W. Cherry and E. D. M. Hooper as Conservators of Forests, notified at page 1132, Part I of the *Fort St. George Gazette*, dated 17th November 1891, take effect from the forenoon of Wednesday the 21st October 1891.

7th December 1891.—No. 535.—M. R. Ry. Dilli Jagannadha Rao Pantulu Garu, Special Forest Settlement Officer, Kurnool, Godavari and Kistna Districts, privilege leave for two months and twenty-eight days, under article 291 of the Civil Service Regulations.

3.—BOMBAY GAZETTE :—

4th December 1891.—Messrs. K. B. Phadke and W. A. Wallinger respectively delivered over and received charge of the Sub-Division Forest Office, Nasik, on the 17th ultimo, after office hours.

7th December 1891.—No. 8455.—His Excellency the Governor in Council is pleased to appoint Mr. G. P. Millett to be Divisional Forest Officer, North Thana, and Mr. L. S. Osmaston to be Divisional Forest Officer, South Thana.

7th December 1891.—Messrs. G. P. Millett, Deputy Conservator of Forests, and K. B. Phadke respectively delivered over and received charge of the South Sub-Division Forest Office, South Thana, on the 27th ultimo, before office hours.

Messrs. G. P. Millett, Deputy Conservator of Forests, and K. B. Phadke respectively delivered over and received charge of the North Sub-Division Forest Office, South Thana, on the 27th ultimo, before office hours.

23rd December 1891.—Messrs. G. P. Millett, Deputy Conservator of Forests, and L. S. Osmaston, Assistant Conservator of Forests, respectively delivered over and received charge of the Divisional Forest Office, South Thana, on the 16th instant, after office hours.

16th December No. 4384.—Mr. H. Mainwaring, Deputy Conservator of Forests, has been allowed by Her Majesty's Secretary of State for India an extension of leave on medical certificate for four months.

4.—BENGAL GAZETTE :—

12th December 1891.—No. 3746 F.—Mr. F. C. Henvey, Assistant Conservator of Forests, on return from the two months' examination leave granted to him in the notification of this Department, dated the 5th October, 1891, is posted to the Jalpaiguri Forest Division for special duty in connection with the preparation of Working-Plans.

Mr. Henvey joined his appointment on the forenoon of the 9th November, 1891.

19th December 1891.—No. 3868 F.—Mr. F. Trafford, who has recently been appointed by Her Majesty's Secretary of State for India to the Forest Department, Bengal, is posted to the Singbhum Forest Division.

29th December, 1891.—No. 3929 F.—In modification of the orders contained in the notification, dated the 6th July, 1891, and 11th September, 1891, published at pages 767 and 836, Part I of the *Calcutta Gazette*, dated, respectively, the 12th August and 16th September, 1891, the following changes in the Upper Controlling Staff of the Forest Department in Bengal are hereby ordered :—

Mr. R. H. M. Ellis, Officiating Deputy Conservator, first grade, to continue to officiate in that grade, with effect from the 4th May, 1891, *vice* Mr. H. H. Davis, Deputy Conservator, first grade, on furlough.

Mr. G. A. Richardson, Deputy Conservator, third grade, to officiate in the second grade of Deputy Conservators, with effect from the 4th May, 1891, to the 30th September, 1891 (both days inclusive).

Mr. E. G. Chester, Deputy Conservator, third grade, to officiate in the second grade of Deputy Conservators, with effect from the 1st October, 1891 (*vide* notification dated the 28th October, 1891).

Mr. C. A. G. Lillingston, Deputy Conservator, fourth grade, to officiate in the third grade of Deputy Conservators with effect from the 4th May, 1891.

Mr. R. L. Heinig, Assistant Conservator, first grade, to officiate in the fourth grade of Deputy Conservators, with effect from the 4th May, 1891.

Mr. H. H. Haines, Assistant Conservator, second grade, to officiate in the first grade of Assistant Conservators, with effect from the above-mentioned date.

Consequent on the grant of three months' privilege leave to Mr. W. M. Green, Deputy Conservator, third grade, with effect from the 9th May, 1891, the following temporary promotions are made from that date :—

Mr. M. S. Fowler, Deputy Conservator, fourth grade, to officiate in the third grade of Deputy Conservators.

Mr. C. G. Rogers, Assistant Conservator, first grade (on deputation to the Dehra Dun Forest School), to officiate in the fourth grade of Deputy Conservators (*seconded*).

Mr. H. D. D. French, Assistant Conservator, first grade, sub. *pro tem.*, to officiate in the fourth grade of Deputy Conservators, *vice* Mr. Rogers, on deputation (*seconded*).

Mr. W. H. Lovegrove, Assistant Conservator, second grade, to officiate in the first grade of Assistant Conservators, *vice* Mr. French.

Consequent on the grant, with effect from the 2nd July, 1891, of nine months' leave on medical certificate out of India to Mr. M. S. Fowler, Officiating Deputy Conservator, third grade, the following temporary promotions are hereby sanctioned :—

Mr. R. L. Heinig, Assistant Conservator, first grade, and Officiating Deputy Conservator, fourth grade, to officiate as Deputy Conservator, third grade.

Mr. H. H. Haines, Officiating Assistant Conservator, first grade, to officiate in the fourth grade of Deputy Conservators.

Consequent on the death of Mr. Fowler, Deputy Conservator, fourth grade, the following promotions are ordered, with effect from the 31st July, 1891 :—

Mr. R. L. Heinig, Assistant Conservator, first grade, and Officiating Deputy Conservator, fourth grade, is confirmed in the latter

grade, but will continue to officiate in the third grade of Deputy Conservators.

Mr. C. G. Rogers, Assistant Conservator, first grade (on deputation), will continue to officiate in the fourth grade of Deputy Conservators, *vice* Mr. Lillingston.

Mr. H. D. D. French, Assistant Conservator, first grade, sub. *pro tem.*, is confirmed in that grade, *vice* Mr. Heinig, but will continue to act in the fourth grade of Deputy Conservators, *vice* Mr. Rogers (*seconded*).

Mr. H. H. Haines, Assistant Conservator, second grade, and Officiating Deputy Conservator, fourth grade, to the first grade of Assistant Conservators sub. *pro tem.*, *vice* Mr. Rogers (*seconded*), but will continue to act in the fourth grade of Deputy Conservators in the chain of Mr. Green, *vice* Mr. French appointed to act in that grade, *vice* Mr. Rogers in the chain of Mr. Davis.

Consequent on the return of Mr. W. M. Green, Deputy Conservator, third grade, from the three months' privilege leave granted to him in the notification, dated the 24th April, 1891, the following re-versions are ordered, with effect from the 9th August, 1891:—

Mr. R. L. Heinig, Officiating Deputy Conservator, third grade, to revert to his substantive appointment of Deputy Conservator, fourth grade.

Mr. H. H. Haines, Officiating Deputy Conservator, fourth grade, to revert to Assistant Conservator, first grade, sub. *pro tem.*

29th December, 1891.—No. 3930F.—Mr. H. H. Haines, Assistant Conservator first grade sub. *pro tem.*, officiated in the fourth grade of Deputy Conservators, with effect from the 9th August, 1891, to the date of expiry of the privilege leave granted to Mr. H. D. D. French, Officiating Deputy Conservator, fourth grade.

5.—N-W. PROVINCES AND OUDH :—

2nd December 1891—No. 5921—With effect from the 1st October 1891, the date on which Mr. L. Mercer, Officiating Deputy Conservator of Forests, returned from privilege leave and resumed charge of the Saharanpur Division, Mr. A. P. Grenfell Assistant Conservator, of Forests in charge of the Saharanpur Forest Division, reverted to the Dehra Dun Forest Division, to which he is attached.

7th December 1891.—No 929F—Under section 4 (c) of the Indian Forest Act, VII of 1878, Pandit Bhawani Dat Joshi, Deputy Collector, is appointed Forest Settlement Officer in connection with the settlement of rights and privileges in the Government of the Kumaun Division; and under section 16 of the said Act the Commissioner of the Kumaun Division is empowered to hear any appeals that may be preferred from the orders of the Forest Settlement Officer.

37.

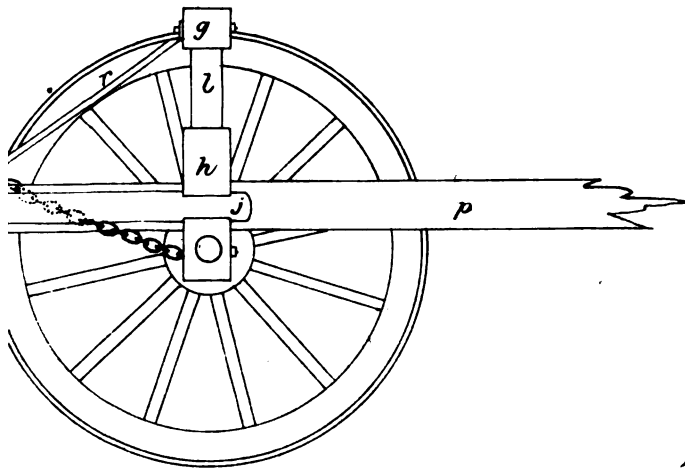

Paragraph
of 29th
make the
effect from

of Extra

of Extra
Grade,

Assistant
No. 200.

A. Down,
assumed
the 4th

and G. G.
and
of the
Patiala

A. Down,
made over
the 4th

the 11th

No. 433,
to the
1891 "

Officers and
Examiners

State for
relations,
No. 1, with

Officer,

Assistant
Inspector

grade, but w
servators.

Mr. C. (t
tion), will o
servators, vi

Mr. H.
pro tem., is
to act in the
(seconded).

Mr. H.
ting Deputy
Conservators
tinue to act
Mr. Green, &
Rogers in th

Consequ
tor, third gra
him in the n
versions are

Mr. R.
to revert to
grade.

Mr. H.
to revert to

29th L
tant Conser
of Deputy
the date of
French, Off

5.—N-W.

2nd L
1891, the o
tor of Fore
the Sahar
of Forests
Dehra Dur

7th D
Forest Act
tor, is app
ment of rig
Division ;
of the Kun
be prefer e

SIDE ELEVATION OF TIMBER C

$$\frac{1}{2}'' = 1'$$

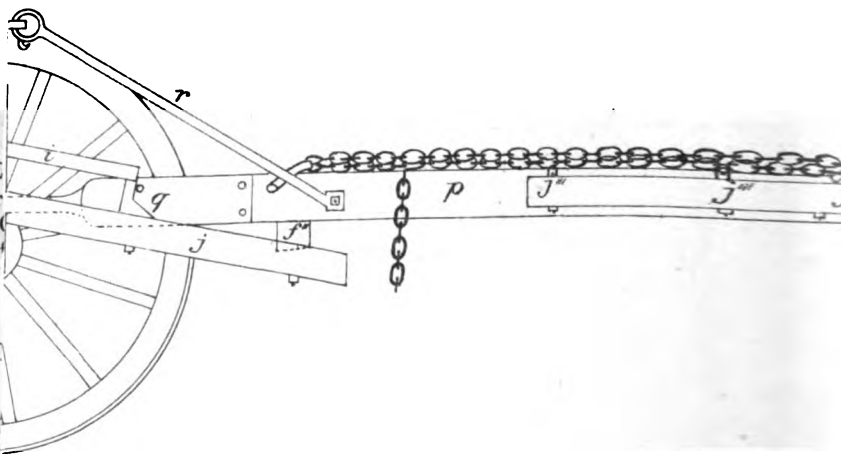

6—PUNJAB GAZETTE :—

5th December 1891. No. 433.—Under the provisions of paragraph 11 of the Circular of the Government of India No. 18 F., dated 29th July 1891, His Honor the Lieutenant-Governor is pleased to make the following appointments to the Punjab Forest service, with effect from the 1st December 1891 :—

1. Mr. C. F. Rossiter, Sub-Assistant Conservator, to be Extra Assistant Conservator, 2nd Grade, on Rs. 300.
2. Bhai Ladha Sing, } Sub-Assistant Conservator, to be Extra
3. Munshi Fazal Din, I, } Assistant Conservators, 3rd Grade,
4. Lala Jowala Proshad, } on Rs 250.
5. Munshi Fazal Din, II, { Forest Ranger, to be Extra Assistant
Conservator, 4th Grade, on Rs. 200.

11th December, 1891 No. 440.—Messrs. E. Forrest and E. A. Down, Deputy Conservators of Forests, respectively made over and assumed charge of the Umballa Forest Division on the forenoon of the 4th December 1891.

12th December, 1891 No. 449.—Messrs. J. H. Luce and G. G. Minniken, Deputy Conservators of Forests, respectively assumed and made over charge of Bashahr Forest Division on the afternoon of the 30th November 1891 consequent on the deputation to the Patiala State of the latter.

19th December, 1891 No. 462.—Messrs. E. Forrest and E. A. Down, Deputy Conservators of Forests, respectively received and made over charge of the Umballa Forest Division on the forenoon of the 4th December 1891.

Punjab Government Gazette Notification No. 440, dated the 11th December 1891, is hereby cancelled.

Erratum.—In *Punjab Government Gazette* Notification No. 433, dated 5th December 1891, publishing certain appointments to the Punjab Forest Service, for “with effect from the 1st December 1891” read “with effect from the 1st November 1891.”

7—CENTRAL PROVINCES GAZETTE :—

19th December, 1891 No. 8616.—The under-mentioned officers and persons are declared to have passed the prescribed Departmental Examination in the subjects and by the standards noted below :—

IN FOREST LAW.

Mr. A. Hunt, Forest Ranger.

23rd December 1891, No. 8752.—Leave on medical certificate for twelve months, under Article 343 of the Civil Service Regulations, is granted to Mr. F.S.Barker, Forest Divisional Officer, Betul, with effect from the date on which he may avail himself of it.

No. 8753.—Mr. A. M. F. Caccia, Forest Divisional Officer, Narsinghpur, is transferred to Betul.

No. 8754.—Mr. Chunder Kumar Chatterji, Extra-Assistant Conservator of Forests, Hoshangabad, is transferred to Narsinghpur as Forest Divisional Officer.

30th December No. 8843.—Mr. V. S. Menzies, Assistant Conservator, attached to the Chanda Forest Division is posted to the Nagpur Wardha Division.

No. 8844.—Mr. N. C. McLeod, Sub-Assistant Conservator, on being relieved of the charge of the Nagpur-Wardha Forest Division, is posted to the Bhandara Forest Division.

No. 8845.—Mr. P. H. Clutterbuck, Assistant Conservator, on being relieved of the charge of the Bhandara Forest Division, is posted to the Chanda Forest Division, for employment in the Pranhita-Godavari Sub-Division.

No. 8846.—With reference to Notification No. 8843, dated the 30th instant, Mr. V. S. Menzies, Assistant Conservator, assumed charge of the Nagpur-Wardha Forest Division from Mr. N. C. McLeod, Sub-Assistant Conservator, on the afternoon of the 15th December 1891.

No. 8853.—The following promotions among Forest Rangers in the Northern Circle are ordered, with effect from the dates specified :—

Mr. A. T. C. Howell, Forest Ranger, 5th grade, to the 4th grade, with effect from the 1st October 1891.

Faiz Baksh, Forest Ranger, 6th grade, to the 5th grade, with effect from the 1st August 1891.

No. 8854.—The following promotions among Forest Rangers in the Northern Circle are ordered, with effect from the 1st October 1891 :—

Faiz Baksh, Forest Ranger, 5th grade, to the 4th grade.

Mr. C. W. Anderson, Forest Ranger, 6th grade to the 4th grade.

Srideo Bajpai, Forest Ranger, 6th grade, to the 5th grade.

8—BURMA GAZETTE :—

1st December 1891.—No. 291.—The following reversions are ordered in the Forest Department, with effect from the date on which Mr J. W. Oliver resumed charge of the Upper Burma Forest Circle from Mr. J. Nisbet :—

Mr. J. Nisbet, Deputy Conservator of Forests, 2nd grade, officiating Conservator of Forests, 3rd grade, to officiate as Deputy Conservator 1st grade.

Mr. C. W. Palmer, officiating Deputy Conservator, 1st grade, to revert to his substantive rank.

Mr. H. B. Ward, officiating Deputy Conservator, 2nd grade, to revert to his substantive rank.

Mr. C. E. Muriel, officiating Deputy Conservator, 3rd grade, to revert to his substantive rank.

3rd December 1891.—No. 11.—With reference to Revenue Department Notification No. 273F, dated the 25th ultimo, Mr. W. F. L. Tottenham, Assistant Conservator of Forests, made over, and Mr. J. Nisbet, Deputy Conservator of Forests, resumed charge of the Rangoon division on the afternoon of the 28th November 1891.

No. 12.—With reference to the Notification above quoted Mr. W. F. L. Tottenham, Assistant Conservator of Forests, assumed charge of his duties in the Tharrawaddy division on the forenoon of the 30th November 1891.

3rd December—No. 270.—At the examinations held at Mandalay, Bhamo, and Mōnywa on the 2nd November 1891 the following Forest Officers passed the examination in Forest Law and Revenue :—

Mr. C. W. A. Bruce, Assistant Conservator,
Mr. C. W. Allan, Extra Assistant Conservator.
Mr. D. L. K. Calderwood, Extra Assistant Conservator.

4th December 1891.—No. 294.—The following promotion is ordered :—

Mr. E. M. Buchanan, Extra Assistant Conservator of Forests, 2nd grade, to be Extra Assistant Conservator, 1st grade.

29th December 1891—No. 322.—The following promotions are ordered with effect from the 2nd November 1891 :—

Messrs. Herbert Carter, E. A. O'Bryen, and W. F. L. Tottenham, Assistant Conservators of Forests, 2nd grade, to be Assistant Conservators, 1st grade.

30th December 1891.—No. 323.—Under the provisions of section 6 (c) of the Burma Forest Act, 1881, the Chief Commissioner appoints Maung Po We, officiating Myoók, Payagale township, Pegu district, to succeed Maung Shwe as the Forest Settlement Officer to enquire into and determine the existence, nature, and extent of any rights claimed by, or alleged to exist in favour of any person in or over any land comprised within the limits specified in Revenue Department Notification No. 237, dated the 13th October 1891, and any claims relating to the practice within the said limits of taungya cultivation, and to deal with the same as provided in Chapter II of the Burma Forest Act, 1881.

9.—ASSAM GAZETTE :—

30th November 1891.—No. 9989G.—With effect from the 1st September 1891.—

Mr. J. C. Kelly, Sub-Assistant Conservator, Second Grade, to be Extra Assistant Conservator, Second Grade.

Babu Jogesvar Sur, Sub-Assistant Conservator, Third Grade, to be Extra Assistant Conservator, Third Grade.

Babu Tarakisor Gupta, Sub-Assistant Conservator, Third Grade, to be Extra Assistant Conservator, Fourth Grade.

10th December 1891.—No. 10,399G.—Mr. T. J. Campbell, Assistant Conservator of Forests, received charge of the Goalpara Forest Division from Mr. D. P. Copeland, Deputy Conservator of Forests, on the forenoon of the 16th November 1891.

24th December 1891.—No. 10,813G.—The services of Babu Upendra Nath Kanjilal, Forest Ranger, Assam, are placed at the disposal of the Government of India, Revenue and Agricultural Department, for employment as Vernacular Instructor at the Imperial Forest School, Dehra Dun.

26th December 1891.—No. 10,821G.—Mr. T. J. Campbell, Assistant Conservator of Forests, having reported his return to duty on the forenoon of the 28th October 1891, the unexpired portion of the furlough granted to him in Notification No. 8,575G., dated the 14th October 1890, is cancelled.

26th December 1891—No. 10,822G.—Mr. D. P. Copeland, Deputy Conservator of Forests, in charge of the Kamrup Forest Division, is placed in charge of the Darrang Forest Division, in addition to his own duties, until further orders.

31st December 1891.—No. 11015G.—Mr. W. F. Lloyd, Assistant Conservator of Forests, Second Grade, is appointed to officiate in the First Grade of Assistant Conservators of Forests, with effect from the 15th November 1891.

10.—HYDERABAD RESIDENCY GAZETTE :—

1st December 1891 No. 302. Mr. S. Shrinivasulu Naidu, a passed student of the Forest School at Dehra Dun, is appointed, on probation, to be Sub-Assistant Conservator of Forests in Berar on Rs. 100 per mensem, with effect from the 5th May 1891.

Mr. Shrinivasulu is posted for duty in the Basim district under the orders of the District Forest Officer, Basim.

11.—MYSORE STATE GAZETTE :—

16th December 1891.—No. 357.—The following transfers and promotion of Forest Officers have been approved and sanctioned :—

Transfers.

1. Mr. B. Ramaswami Iyer, Officiating Assistant Conservator of Forests, from Mysore to Kadur District.
2. Mr. Y. Sitaramaiya, Assistant Conservator of Forests, from Kadur to the Mysore District.
3. Mr. E. P. Lavery, Officiating Superintendent of Forests, from Shimoga to the Bangalore District.
4. Mr. C. Narayana Rao, Assistant Conservator of Forests, from Bangalore to the Shimoga District.
5. Mr. S. A. Bapu Rao, Assistant Conservator in charge of Plantations, to the Hassan District.
6. Mr. H. Muttappa, Sub-Assistant Conservator of Forests, from Hassan to the Tumkur District.
7. Mr. B. Srinivas Rao, Sub-Assistant Conservator of Forests, from Tumkur to the Kolar District.

Promotion.

Mr. G. Ricketts, Forest Probationer attached to the Head-quarters, to the Grade of Sub-Assistant Conservator of Forests and to be in charge of the Plantation Department.

VIII.—EXTRACTS FROM OFFICIAL GAZETTES.

1.—GAZETTE OF INDIA.—

14th January, 1892.—No. 56-F.—With reference to the Notification by the Chief Commissioner of Assam, No. 10813 G., dated the 24th ultimo, Babu Upendra Nath Kanjilal, Forest Ranger, Assam, is appointed to be an Instructor at the Forest School, Dehra Dún, under the terms of paragraph 10 (i) of the Circular Resolution of this Department, No. 18 F., dated the 29th July last, and with effect from the date on which he assumed charge of his duties.

2.—MADRAS GAZETTE.—

19th December 1891.—*Transfers*.—1. Ranger V. C. Doraisawmi Pillai, from North Arcot to Trichinopoly.

2. Ranger Mr. Jembunatha Sastri, from the Trichinopoly District to Salem District.

3. Ranger Mr. A. M. Clay, from Salem to North Arcot.

20th December 1891.—*Leave*.—Mr. W. P. Rego, Ranger, Second Class, is granted privilege leave for one month, from or after 22nd December 1891.

21st December 1891.—*Leave*.—Forest Ranger Mr. H. Stafford, is granted two months' leave on medical certificate from the 3rd December 1891.

9th January 1892.—*Leave*.—The Board of Revenue (Land Revenue) has granted an extension of seven day's privilege leave, under Article 291 of the Civil Service Regulations, to Mr. J. S. Battie, District Forest Officer of Ganjam, in continuation of the fifteen days' privilege leave notified at page 1508, Part II, of the *Fort St. George Gazette*, dated 27th October 1891.

18th January 1892.—No. 19.—Mr. A. W. Peet to be Second-grade Conservator of Forests (permanent).

No. 20.—Mr. J. W. Cherry to be Third-grade Conservator of Forests, (permanent).

No 21—Mr. J. W. Cherry to act, as Conservator of Forests, Second Grade, during the absence of Mr. A. W. Peet on leave or until further orders

No. 22.—Mr. E. D. M. Hooper to act as Conservator of Forests Third Grade, during the absence of Mr. J. W. Cherry on other duty, or until further orders.

The above appointments to take effect from the 21st October 1891 A.M.

18th January 1892.—M. Jambunada Sastri, Forest Ranger, Fourth Grade (under transfer to Salem), will be considered to have been on leave on medical certificate, under article 369 of the Civil Service Regulations, for nine days from 23rd November 1891.

19th January 1892.—No. 25.—Messrs. J. L. McO'Leary and F. C. L. Cowley-Brown, Trained Forest Officers appointed by Her Majesty's Secretary of State for India, having reported their arrival in Madras on the forenoon of the 26th December 1891, are brought upon the strength of the Madras Forest Department as Assistant Conservators, Third Grade, with effect from that date, and are posted to do duty under the Examiner of Forest Accounts.

19th January 1892.—No. 26.—

Name.	Present grade.	Grade to which promoted.	Grade to which reverted.	Nature of promotion or reversion.	Remarks.
Mr. C. E. Brasier ..	Deputy Conservator of Forests, 4th Grade	Deputy Conservator of Forests, 3rd Grade.	..	Acting ..	From the date of Mr. Brasier's joining Tinnevely.
Mr. F. A. Lodge ..	Acting Conservator of Forests, 3rd Grade.	..	Deputy Conservator of Forests, 4th Grade.	Do ..	

15th January 1892.—No. 70.—(Military Department) Colonel Campbell-Walker, Indian Staff Corps, has been permitted by the Right. Honorable the Secretary of State for India to retire from the service with effect from the 17th January 1892, subject to Her Majesty's approval.

3.—BOMBAY GAZETTE.—

4th January 1892.—No. 14.— In exercise of the power conferred by Section 4 of the Indian Forest Act No. VII of 1878, as amended by Act No V of 1890 and with reference to Government Notification No. 6548, dated 16th September 1886, published at page 805 of the *Bombay Government Gazette* of the 23rd idem, Part I, His Excellency the Governor in Council is pleased to appoint, *vice* Mr. R. T. Wingate proceeding on leave, Mr. W. D. Sheppard, C. S., to be Forest Settlement Officer for the Kánara District for the purposes set forth in Section 4, clause (c), and Section 34 of the said Act, and in respect of all lands in the said District up to this date notified as proposed Reserved Forests under Section 4, or as Reserved Forests under Section 34, which have not since been disforested under Section 26 and in respect of which the inquiry into rights contemplated by clause (c) of Section 4 of the said Act has not yet been made.

2. Under Section 16 of the said Act, His Excellency the Governor in Council is also pleased to appoint the Collector of Kánara to hear appeals from any orders passed by the said Forest Settlement Officer under Sections 10, 11, 14 or 15 of the said Act.

3. His Excellency the Governor in Council is pleased to direct that the inquiry and record in respect of the Protected Forests of the said district shall be made and prepared in the same manner and subject to the same provisions and right of appeal as in the case of Reserved Forests.

6th January 1892.—No. 43.—Mr. G. A. Hight, Deputy Conservator of Forests Second Grade, and Divisional Forest Officer, Dhárwár, is allowed privilege leave of absence for three months with effect from 20th January 1892 or from such subsequent date as he may avail himself of it.

6th January 1892.—Messrs. K. B. Phadke and A. N. Master respectively delivered over and received charge of the North Sub-Division Forest Office, South Thána on the 17th December 1891, after office hours.

Messrs. L. S. Osmaston, Assistant Conservator of Forests, and G. P. Millett, Deputy Conservator of Forests, respectively delivered over and received charge of the office of the Divisional Forest Officer, North Thána, on the 16th December 1891, after office hours.

14th January 1892.—Messrs. F. Gleadow and H. Murray, Deputy Conservators, respectively delivered over and resumed charge of the Divisional Forest Office, Belgaum, on the forenoon of the 11th instant.

21st January 1892.—Messrs. K. B. Phadke and W. F. D. Fisher respectively delivered over and received charge of the South Sub-Division Forest Office, South Thána, on the 5th instant, after office hours.

25th January.—No. 538.—Mr. L. S. Osmaston, Assistant Conservator of Forests, Third Grade, is promoted to the Second Grade from 15th October 1891.

5.—N.-W. PROVINCES AND OUDH GAZETTE.—

7th January, 1892.—No. 44.—Mr. F. A. Leete, who has been appointed to the Forest Department by the Right Hon'ble the Secretary of State for India, and who reported his arrival at Allahabad on the 31st December 1891, to be an Assistant Conservator of Forests, 2nd grade, and to be posted to the Garhwal Forest Division of the Central Circle.

No. 48.—Mr. J. C. Tulloch, who has been appointed to the Forest Department by the Right Hon'ble the Secretary of State for India, and who reported his arrival at Allahabad on the 31st December 1891, to be an Assistant Conservator of Forests, 2nd grade, and to be posted to the Gorakhpur Forest Division of the Oudh Circle.

20th January 1892.—No. 35.—The Hon'ble the Lieutenant-Governor, and Chief Commissioner, is pleased to declare the undermentioned gentleman to have passed the Departmental Examination of Junior Officers, held on the 19th October 1891 and following days, in the subjects specified below :—

V.—FOREST OFFICER.

Vernacular.

By Higher Standard.

Babu Har Sarup, Extra Assistant Conservator.

21st January 1892.—No. 24.—In Notification No. 449, dated the 12th December 1891, notifying the date on which Mr. Lacey, Deputy Conservator of Forests, assumed charge of the Bashahr Forest Division from Mr. G. G. Minniken, Deputy Conservator of Forests, for "afternoon" read "forenoon."

Erratum.—6.—PUNJAB GAZETTE.—

23rd January 1892.—No. 32.—Messrs. E. Forrest and E. A. Down, Deputy Conservators of Forests, respectively made over and received charge of the Umballa Forest Division on the forenoon of the 4th January 1892 on the return from privilege leave of the latter officer.

No. 35.—Lála Jowála Prasád, Extra Assistant Conservator of Forests, and Mr. E. Forrest, Deputy Conservator of Forests, respectively made over and received charge of the Rawalpindi Forest Division on the afternoon of the 8th of January, 1892.

7.—CENTRAL PROVINCES GAZETTE.—

7th January 1892.—No. 130.—The following Officers of the Forest Department have passed the prescribed examination in the Vernacular, as shown below:—

MARATHI.

By the Lower Standard.

Mr. A. E. Lowrie, Deputy Conservator of Forests.

HINDI.

By the Lower Standard.

Mr. V. S. Menzies, Assistant Conservator of Forests.

23rd January 1892.—Mr. H. S. K. Edie, who has been appointed by H. M's. Secy. of State for India to be an Assistant Conservator of Forests, 2nd grade, and has been posted to the Central Provinces, reported his arrival at Bombay on the forenoon of the 21st ultimo, and at Nagpur on the forenoon of the 31st idem.

26th January 1892.—No. 438.—With reference to Notifications Nos. 8844 and 8845, dated the 30th December 1891, Mr. P. H. Clu terbuck, Assistant Conservator, made over charge of the Bhandara Forest Division to Mr. N. C. McLeod, Extra-Assistant Conservator, on the forenoon of the 2nd instant.

8.—BURMA GAZETTE —

7th January 1892.—No. I.—In supersession of Revenue Department Notification No. 185, dated the 2nd September 1891, and in exercise of the power conferred by section 33 of the Upper Burma Forest Regulation, 1887, the Chief Commissioner directs that the following rule shall be added to the rules published in Revenue Department Notification No. 59, dated the 11th April 1889:—

“5(a) No person shall cut, saw, convert, or remove any dead or girdled teak trees on land not included in a reserved or village forest, or the timber of any such tree, save under and subject to the conditions of a license granted by the officer in charge of a forest division or sub-division.

"Applications for licenses under this rule may be made to any Township or Sub-divisional Officer, who will forward them to the District Forest Officer for disposal. No license shall be refused by the District Forest Officer, without the approval in writing of the Deputy Commissioner of the district."

Provided that this rule should not apply to any Shan State except the State of Momeik.

11th January 1892.—No. I.—With reference to Revenue Department Notification No. 272 (Forests), dated the 25th November 1891, Mr. J. Messer, Assistant Conservator of Forests, assumed charge on the forenoon of that date of his duties as a specially appointed Working Plans Officer.

14th January 1892.—No. 4.—The following transfers are ordered consequent on the grant of furlough to Mr. J. Nisbet, Deputy Conservator of Forests :—

Mr. W. F. L. Tottenham, Assistant Conservator of Forests, from the Tharrawaddy Division to the charge of the Rangoon Division.

Mr. G. R. Long, Assistant Conservator of Forests, from Pegu to the Tharrawaddy Division.

No. 5.—The following transfers are ordered :—

Mr. A. M. Burn-Murdoch, Assistant Conservator of Forests, on relief by Mr. Samuel Carr, Assistant Conservator, from Yaméthin to the Taungwingyi sub-division of the Minbu Forest Division.

Mr. R. F. Lewis, Extra Assistant Conservator of Forests, from Pyinmana to the Ruby Mines sub-division of the Katha Forest division.

No. 6.—Under the provisions of Article 340 (b) of the Civil Service Regulations, furlough to Europe for one year, seven months, and six days is granted to Mr. John Nisbet, Deputy Conservator of Forests, with effect from the 1st February 1892, or the subsequent date on which he may avail himself of it.

21st January 1892.—No. 9.—With the sanction of the Government of India Mr. J. Allmark, the officer in charge of the Government Timber Depôt and Agency at Rangoon, is appointed to be an Extra Assistant Conservator of Forests, 1st grade, with effect from the 1st January 1892.

28th January 1892.—No. 24.—Mr. Samuel Carr, who has been appointed by the Secretary of State for India to be an Assistant Conservator of Forests in this province, arrived in Rangoon on the 3rd January 1892, before noon.

Mr. Carr is posted to the Pyinmana Forest division, Upper Burma.

9.—ASSAM GAZETTE.—

5th January 1892.—No. 60G.—In supersession of General Department Notification No. 9915G., dated the 26th November 1891, published at page 582 of the *Assam Gazette* of the 28th idem, privilege leave of absence for two months, under article 291 of the Civil Service Regulations, is granted to Mr. J. T. Jellicoe, Deputy Conservator, Darrang Forest Division, with effect from the 4th December 1891.

5th January 1892.—No. 61G.—Mr. J. T. Jellicoe, Deputy Conservator of Forests, made over charge of the Darrang Forest Division to Mr. D. P. Copeland, Deputy Conservator of Forests, Kamrup, on the forenoon of the 4th December 1891.

28th January 1892.—No. 833G.—Mr. T. J. Campbell, Assistant Conservator of Forests, on return from furlough on the afternoon of the 9th November 1891, was attached to the Goalpara Forest Division, and received charge of that division from Mr. D. P. Copeland, Deputy Conservator of Forests, on the forenoon of the 16th idem.

No. 824G.—Mr. C. G. D. Fordyce, Deputy Conservator of Forests, Sibsagar Division, is transferred to the Lakhimpur Forest Division, but will continue to hold charge of the Sibsagar Division in addition to his own duties.

VIII.—EXTRACTS FROM OFFICIAL GAZETTES.

2.—MADRAS GAZETTE.—

29th January 1892.—No. 48.—Mr. C. E. Brasier, District Forest Officer of Tinnevely, to be District Forest Officer of Salem.

No. 49.—Mr. Du Pré, Thornton, Assistant Conservator, to act as District Forest Officer of Tinnevely.

9th February 1892.—No. 100.—Military Department. Colonel G. J. vanSomeren, General List, Infantry, has been permitted by the Right Honorable the Secretary of State for India, to retire from the service, with effect from the 1st February 1892, subject to Her Majesty's approval.

30th January 1892.—K. Rama Row, Ranger, Bellary District, is granted on half pay leave of absence for one month from 12th January, 1892.

20th February 1892.—The following is the result of the Departmental Examination in Forest Law, Code and Accounts (para. 56 (a) and (b) of the Departmental Code) held on the 22nd January, 1892 :—

Name of Officer.	Designation.	District to which attached.	Degree of success, i.e., whether passed in Forest Law or Code & Accounts, or in both.
V. Janardan Nayudu ..	Acting Clerk, District Forest Officer ..	North Arcot	Passed in both.
Mr. Christopher Vieyra ..	Forester ..	Do. ..	Do.
A. Govindaswami Pillai ..	Range Clerk ..	South Arcot	Do.
Syed Burhanuddin Hussainy ..	Forester ..	Do. ..	Do.
M. Padmanabhaচার ..	Range Clerk ..	Do. ..	Do.
Ahmed Hussain ..	Forester ..	Salem ..	Passed in Forest Law.
Mahomed Abdul Hakim ..	Do. ..	Nellore ..	Do.
V. S. Tiruvengadam Mudaliar	Clerk, District Forest Office. ..	Do. ..	Do.
C. Srinivasalu Nayudu ..	Range Clerk ..	North Arcot	Do.
Mahomed Abdul Ali Sahib ..	Forester ..	Do. ..	Do.
Subramaniya Aiyar ..	Plantation Supervisor.	South Arcot	Do.
Srinivasa Raghavachari ..	Forester ..	Do. ..	Do.
K. Narayanaswami Aiyar ..	Range Clerk ..	Do. ..	Do.
T. M. Ramachandra Rao ..	Do. ..	Do. ..	Passed in Code & Accounts.

22nd February 1892.—C. M. Karunakara Menon, Forester, North Malabar Division, has passed the Departmental Examination in Parts (a) and (b) of para. 56 of the Forest Code, held in January 1892.

Mr. C. Hammond, Forest Ranger, V Class, on probation, Madura District, has passed the Departmental Examination in Parts (a) and (b) of the Forest Code, para. 56, held in January 1892.

The undermentioned candidates have passed the Departmental Examination in Parts (a) and (b) of para. 56 of the Forest Code, held in January 1892 :—

Nilgiris.

1. Mr. C. V. Ryan, Forester, I Class.
2. T. V. Armugam Pillai, Forester, IV Class.
3. S. V. Venkatramana Iyer, Temporary Clerk, District Forest Office, with credit.

24th February 1892.—Forest Ranger A. S. Mariapragasam Pillai is granted privilege leave of absence for two months from date of relief—to be reported.

25th February 1892.—Forest Ranger T. C. Malaya Pillai is granted privilege leave of absence for one month, with effect from the 2nd February, 1892.

3.—BOMBAY GAZETTE.—

8th February 1892.—Mr. K. B. Phadke, Acting Sub-Assistant Conservator of Forests, reported himself for duty to the Conservator of Forests, N. C., on the 11th January, 1892, before office hours, and was attached to the Conservator's Office.

2. Mr. Phadke has been, since 1st instant, temporarily attached to the Surat Division, to supervise the timber operations in the Dāngs.

9th February 1892.—Messrs. G. A. Hight and G. F. Gleadow, Deputy Conservators of Forests, respectively delivered over and received charge of the Dhārwar Forest Division on the 28th January, 1892, before noon.

10th February 1892.—No. 625.—Mr. C. Greatheed, Deputy Conservator of Forests, Third Grade, and Divisional Forest Officer, Kolábaratnāgiri, is allowed furlough for nine months.

11th February 1892.—Mr. Joseph Baptista, L. C. E., South Sub-division Forest Officer, North Thána, and Mr. A. C. Robinson, L. C. E., North Sub-division Forest Officer, North Thána, respectively delivered over and received charge of the South Sub-division Forest Office on the 18th January, 1892, after office hours.

20th February 1892.—Mr. C. M. Hodgson, Assistant Conservator of Forests, who was in Government Resolution No. 3086 of 30th October, 1891, granted examination leave from 6th November 1891, resumed charge of his duties on the 23rd December, 1891, before office-hours.

4.—BENGAL GAZETTE.—

No. 644 For.—*The 23rd February 1892.*—In continuation of the Notification of this Department, No. 3508 For., dated the 24th November, 1891, published at page 996, Part I of the *Calcutta Gazette* of the 25th idem, a further extension of leave on medical certificate for five weeks, under articles 266 and 369 of the Civil Service Regulations, is granted to Babu Shama Charan Chuckerbutty, Extra-Assistant Conservator of Forests.

5.—N.-W. P. AND OUDH GAZETTE.—

21st January 1892.—No. 253.—Pandit Budhi Ballabh, Tewári, Forester, 1st grade, on Rs. 40, in the Naini Tal Division, is promoted to be a Forest Ranger of the 6th grade, on Rs. 50, with effect from the 1st January, 1892.

25th January 1892.—No. 29.—Pandit Mukandi Lál, Forester, 2nd grade, on Rs. 35, in the Dehra Dún Division, is appointed to be a Forest Ranger of the 6th grade, with effect from the 1st January, 1892.

4th February 1892.—No. 310.—Mr. E. L. Haslett, Extra-Assistant Conservator of Forests, on special duty, Kumaun Division, leave on medical certificate for eight days, with effect from the 4th January, 1892.

13th February 1892.—No. 34.—The following promotions in the Staff of Forest Rangers in the School Circle have been sanctioned by Government, with effect from 5th February, 1892.

From the 3rd to the 2nd grade, Pandit Sadanand.
 ,, 5th to the 3rd ,, Paudit Ráma Dutt.

15th February 1892.—No. 434.—Mr. A. P. Grenfell, Assistant Conservator of Forests, attached to the Dehra Dún Forest Division, to the Jaunsar Forest Division, to do duty under the Divisional Officer, with effect from the 15th March, 1892.

17th February 1892.—No. 500.—Mr. E. A. Down, Deputy Conservator of Forests, whose services have been placed at the disposal of this Government by the Government of the Panjáb, to the charge of the Ganges Division of the Central Circle.

No. 504.—Mr. B. B. Osmaston, Officiating Deputy Conservator of Forests, to be attached to the Direction Division of the Central Circle, as Working Plans Officer.

6.—PANJAB GAZETTE.—

29th January 1892.—No. 44.—His Honor the Lieutenant-Governor is pleased to sanction the grant of 36 days privilege leave to Bhái Laha Singh, Extra Assistant Conservator of Forests, Kángra Division, of which he availed himself on the afternoon of the 11th January, 1892.

1st February 1892.—No. 48.—Mr. A. E. Wild, Officiating Conservator of Forests, Panjab, is granted furlough for one year under Article 340 (b) (2) of the Civil Service Regulations, with effect from the 16th of March 1892, or such subsequent date as he may avail himself of it.

13th February 1892.—No. 77.—With reference to the Notification of the Government of India, in the Department of Revenue and Agriculture, No. 134 F., dated the 29th December, 1891, the services Mr. E. A. Down, Deputy Conservator of Forests, are placed at the disposal of the Government of the North-Western Provinces and Oudh.

Mr. Down made over charge of the Umballa Forest Division to Lála Jowála Parshád, Extra Assistant Conservator, on the afternoon of the 1st February, 1892.

7.—CENTRAL PROVINCES GAZETTE.—

9th February 1892.—No. 360.—In exercise of the powers conferred by Sections 41 and 42 of the Indian Forest Act, VII of 1878, and with the previous sanction of the Governor-General in Council, the Chief Commissioner of the Central Provinces is pleased to publish the following Rules to regulate the transit of timber and other forest-produce and the use of property-marks for timber :—

I.—Regulating the transit of timber and other forest-produce.

1. The Conservator of Forests may, with the previous sanction of the Chief Commissioner, prescribe a route or routes by which alone timber or other forest-produce may be removed from a specified Reserved Forest in his Circle, and shall establish a depôt or depôts on such route or routes for the examination of such timber or other forest-produce while in transit and for the collection of dues (if any) payable thereon.

2. The name and situation of every such route and depôt shall be notified in every town and village in the neighbourhood of such forest.

3. After the expiration of three months from the date of such Notification, no timber or other forest produce from such forest shall be moved except by a prescribed route and under a pass issued by a Forest Officer authorized in this behalf by the Conservator.

4. The Conservator of Forests may, with the previous sanction of the Chief Commissioner, exempt the inhabitants of any local area or any class of timber or other forest-produce from the operation of Rule 3.

II.—Regulating the use of property-marks for timber.

5. No unregistered property-mark shall be impressed on any log for square in a Government Forest or in transit therefrom.

6. Any person may apply to the Divisional Forest Officer to have a property-mark, to be attached to timber belonging to him, registered in the office of the Conservator of the Circle. Such application shall be forwarded to the Conservator for disposal in accordance with the following rules.

7. Every property-mark shall consist of a device to be approved by the Conservator : provided that no person shall be allowed to register a mark identical with, or liable to be mistaken for, one already registered by another person or used by the Government. The mark ordinarily used by the Government shall be the broad arrow. In case of dispute as to whether a mark proposed for registration has or not too close a resemblance to another previously registered, the matter shall be referred to the Conservator, whose decision shall be final.

8. A fee of Rs. 2 shall be payable for registration, and such registration shall hold good for the two years following the 1st of January next after the date of registration.

9. A certificate of registration, showing the device registered, shall be given by the Conservator to each person registering his mark. The certificate shall state the period for which the registration will hold good.

10. Marks used by the Government shall be impressed on the centre portion of all logs or squares, a space of 18 inches on either side of a line drawn round the centre being reserved for such marks; and no private property-mark shall be impressed within the said space. Beyond that space the owner may impress his mark where and as often as he pleases.

III.—Penalties.

11. Any person moving timber or other forest-produce in contravention of Rule 3, or using an unregistered property-mark in contravention of Rule 5, or using a registered property-mark after expiry of the period for which the registration holds good or impressed in contravention of Rule 10, shall be liable to a fine not exceeding 200 (two hundred) rupees.

8.—BURMA GAZETTE.—

3rd February 1892.—No. 1.—With reference to Revenue Department Notification No. 5, dated Rangoon, the 14th January 1892, Mr. A. M. Burn Murdoch and Mr. R. F. Lewis assumed charge of the Taungdwingyi and Ruby Mines sub-divisions of the 29th and 16th January, 1892, respectively.

5th February 1892.—No. 34.—Under the provision of section 70 of the Burma Forest Act, 1881, the Chief Commissioner invests Mr. W. T. T. McHarg, Assistant Conservator of Forests in charge of the Kado Forest sub-division, with the following powers, that is to say:—

- (1) The powers of a Civil Court to compel the attendance of witnesses and the production of documents.
- (2) Power to issue search warrants under the Code of Criminal Procedure.
- (3) Power to hold enquiries into forest offences and in the course of such enquiries to receive and record evidence.

15th February 1892.—No. 50.—Mr. J. T. Jellicoe, Deputy Conservator of Forests, reported his arrival in Rangoon on the 13th February, 1892, after noon, and is posted to the charge of the Rangoon Forest division, with effect from the date on which he assumes charge from Mr. Tottenham.

16th February 1892.—No. 56.—With effect from the date on which he may be relieved of the charge of the Rangoon Forest Division by Mr. J. T. Jellicoe, Deputy Conservator of Forests, Mr. W. F. L. Tottenham, Assistant Conservator of Forests, is attached to the Rangoon Forest Division.

15th February 1892.—No. 2.—With reference to Revenue Department Notification dated the 14th ultimo, Mr. J. Nisbet, Deputy Conservator of Forests, made over and Mr. W. F. L. Tottenham, Assistant Conservator of Forests, received charge of the Rangoon division on the afternoon of the 12th instant.

No. 3.—With reference to Revenue Department Notification No. 50, dated the 15th instant, Mr. W. F. L. Tottenham, Assistant Conservator of Forests, made over and Mr. J. T. Jellicoe, Deputy Conservator of Forests, received charge of, the Rangoon division, on the forenoon of the 15th instant.

18th February 1892.—No. 2.—With reference to Revenue Department Notification No. 5, dated Rangoon, the 14th January, 1892, Mr. S. Carr, Assistant Conservator of Forests, reported his arrival at Pyinmana on the forenoon of the 8th January, and received charge of the Yaméthin sub-division from Mr. A. M. Burn-Murdoch, Assistant Conservator of Forests, on the afternoon of the 9th January, 1892.

9.—ASSAM GAZETTE.—

4th February 1892.—No. 977 G.—Mr. A. M. Long, who has been appointed by Her Majesty's Secretary of State to the Forest Department in Assam, having reported his arrival in India on the afternoon of the 28th December 1891, is attached to the Kamrúp Forest Division.

23rd February 1892.—No. 612R.—With reference to clause (3), section 1 of Regulation VII of 1891 (The Assam Forest Regulation, 1891), which was published in the *Assam Gazette* of the 9th, 16th, and 23rd January 1892, the Chief Commissioner hereby directs that the said Regulation shall come into force on the first day of April, 1892.

10.—MYSORE STATE GAZETTE.—

6th February 1892.—No. 432.—Mr. M. Venkatanaranappa, Sub-Assistant Conservator of Forests, Shikarpur Sub-Division, is granted privileige leave of absence for 2½ months from the 2nd February, 1892, or from such other date as he may have availed himself of the same.

8th February 1892.—No. 436.—Mr. H. Muddappa, Sub-Assistant Conservator of Forests, Hassan District, was granted three days' casual leave of absence from the 20th ultimo.

11.—HYDRABAD RESIDENCY GAZETTE.—

26th January 1892.—The Resident is pleased to make the following promotions and appointments among Sub-Assistant Conservators of Forests in Berar with effect from the 1st October, 1891 :—

Mr. Mansukh Rai, Sub-Assistant Conservator on Rs. 200, to be Sub-Assistant Conservator on Rs. 250.

Mr. Ahmed Ali, Sub-Assistant Conservator on Rs. 150 (and Tahsildar of the Melghat), to be Sub-Assistant Conservator on Rs. 200, *vice* Mr. Mansukh Rai, and to continue to perform the duties of Tahsildar of the Melghat as heretofore.

Mr. C. H. Haldane, Sub-Assistant Conservator on Rs. 150, to be Sub-Assistant Conservator on Rs. 200, to make up sanctioned complement.

Mr. B. Bhukhan, Officiating Sub-Assistant Conservator, is confirmed in his appointment on Rs. 150, *vice* Mr. G. H. Wittinbaker, dismissed.

VIII.—EXTRACTS FROM OFFICIAL GAZETTES.

1.—GAZETTE OF INDIA.—

22nd March, 1892.—No. 189.—Privilege leave for three months under Article 291 of the Civil Service Regulations is granted to Mr. C. G. Rogers, Instructor at the Forest School, Dehra Dún, with effect from the 30th March, 1892, or the subsequent date on which he may avail himself of it.

2.—MADRAS GAZETTE.—

5th March 1892.—Appointment No. 84.—Mr. E. P. Popert, Acting Conservator of Forests, First Grade, is confirmed in that grade, with effect from 17th January 1892, *vice* Colonel Campbell Walker, retired.

ERRATUM.

10th March 1892.—In Notification No. 25 of the Revenue Department, published at page 94, Part I, of the *Fort St. George Gazette* of 19th January 1892—

For "Assistant Conservators, 3rd Grade,"

Read "Assistant Conservators, 2nd Grade."

12th March 1892.—No. 94.—Mr. G. Hadfield, District Forest Officer, South Malabar, is granted privilege leave for three months, from or after 1st March 1892, under article 291, Civil Service Regulations.

No. 95.—Furlough for twelve months is granted, under article 340 Civil Service Regulations, to Mr. T. P. Peake, Assistant Conservator of Forests, First Grade, and Acting Deputy Conservator, Third Grade, South Canara.

No. 96.—Furlough for eighteen months is granted, under article 340, Civil Service Regulations, to Mr. H. J. A. Porter, Deputy-Conservator of Forests, Third Grade, Coimbatore (South).

12th March 1892.—No. 97.—Mr. H. B. Bryant, Assistant Conservator of Forests, to act as District Forest Officer, South Coimbatore, during Mr. H. J. A. Porter's absence on leave or until further orders.

No. 98.—Mr. F. Foulkes, Assistant Conservator of Forests, to act as District Forest Officer, South Canara, during Mr. T. P. Peake's absence on leave, or until further orders.

No. 99.—Mr. W. P. Rego, Forest Ranger, Second Grade, to act as District Forest officer, South Malabar, during Mr. G. Hadfield's absence on leave, or until further orders.

3.—BOMBAY GAZETTE.

5th March, 1892.—Messrs A. C. Robinson and J. Baptista, Sub-Division Forest Officers, respectively delivered over and received charge of the North Sub-Division Forest Office, North Thána, on the 18th February 1892, after office hours.

4.—BENGAL GAZETTE.

5th March, 1892.—Mr. E. J. N. James, Extra Assistant Conservator of Forests, attached to the Sunderbuns Forest Division, is transferred to the Singbhum Forest Division.

15th March, 1892.—No. 1059For.—Under the provisions of section 25 (i) of the Indian Forest Act, (Act VII of 1878), the Lieutenant-Governor is pleased to sanction the closing of the Reserved forests in the Singbhum, Palámau, and Hazáribágh Forest Divisions against hunting shooting, and fishing from the 25th March, 1892, to the 15th June, 1892, except with the written permission of the Conservator of Forests or the Local Government.

18th March, 1892.—No. 1162For.—In continuation of the orders contained in the Notification of this Department, No. 644For., dated the 23rd February, 1892, published at page 219, Part I of the *Calcutta Gazette* of the 24th idem, a further extension of sick leave on medical certificate for six months, under Articles 266 and 369 of the Civil Service Regulations, is granted to Babu Shama Charan Chuckerbutty, Extra Assistant Conservator of Forests.

5.—N.-W. PROVINCES AND OUDH GAZETTE.—

9th March 1892.—No. 239F.—Substitute the following for this Department Notification No. 929F. doted 7th December 1821, printed on pages 608 and 609, Part I of the *North-Western Provinces and Oudh Government Gazette* of the 12 idem.

Under section 4(c) of the Indian Forest Act, VII of 1878, Pandit Bhawani Das Joshi, Deputy Collector, is appointed Forest Settlement Officer in connection with the settlement of rights in the Government forests of the Kumaun Division; and, under section 16 of the said Act, the Commissioner of the Kumaun Division is empowered to hear any appeals that may be preferred from the orders of Forest Settlement Officer.

21st March 1892.—No. 1175.—Pandit Raghubar Dayal Bajpai Superintendent of the Baharámghat Timber Depôt, is placed on special duty in the Pilibhit Division of the Oudh Forest Circle, as a temporary arrangement.

21st March 1892.—No. 1179.—Lála Har Sarup, Extra Assistant Conservator of Forests, Pilibhit Forest Division, to officiate as Superintendent of the Bahrámghat Timber Depôt, during the absence, on deputation of Pandit Raghubar Dayal Dayal Bajpai, or until further orders.

22nd March 1892.—No. 1209.—Mr. E. A. Down, Deputy Conservator of Forests, furlough out of India for seven months, with effect from the 23rd April, 1892, or subsequent date.

6.—PUNJAB GAZETTE.—

29th February 1892.—No. 97.—Mr. G. S. Hart, Assistant Conservator of Forests, on return from leave on urgent private affairs granted in Punjab Government Notification No. 265S, dated 10th July, 1891, is placed on special duty with effect from the afternoon of the 13th February, 1892,

16th March 1892.—No. 140.—Babu Ladha Singh, Extra Assistant Conservator of Forests, on return from the privilege leave granted to him in *Punjab Gazette* Notification No. 44, dated 29th January, 1892, resumed charge of his duties in the Kangra Division on the forenoon of the 12th February, 1892.

No. 143.—Munshi Fazal Din, II, Extra Assistant Conservator of Forests, 4th Grade from the 11th January, 1892 to 11th February, 1892, both days inclusive, *vice* Babu Ladha Singh on privilege leave.

No. 146 — Lala Jowala Prasad, Extra Assistant Conservator and Mr. G. S. Hart, Assistant Conservator of Forests, respectively made over and received charge of the Umballa Forest Division on the afternoon of the 3rd March, 1892, on return of the latter from special duty.

7.—CENTRAL PROVINCES GAZETTE.—

2nd March 1892.—No. 643.—Mr. Chunder Kumar Chatterjee Extra Assistant Conservator of Forests, transferred to Narsinghpur by Notification No. 8754, dated the 23rd December, 1891, assumed charge of the office of District Forest Officer of that district on the afternoon of the 18th January, 1892.

No. 644.—Mr. A. M. F. Caccia, Assistant Conservator of Forests 2nd grade, transferred to Betul by Notification No. 8753, dated the 23rd December, 1891, assumed charge of the office of District Forest Officer of that district on the afternoon of the 21st January, 1892.

No. 645.—Mr. F. S. Barker, Deputy Conservator of Forests, Betul, availed himself, on the 22nd January, 1892, of the twelve months' leave on medical certificate granted to him by Notification No. 8752, dated the 23rd December, 1891, making over charge of his duties to Mr. A. M. F. Caccia, Assistant Conservator of Forests.

No. 648.—With reference to Notification No. 8845, dated the 30th December, 1891, Mr. P. H. Clutterbuck, Assistant Conservator of Forests, assumed charge of the Pranhita-Godavari Forest Sub-division of the Chanda District on the forenoon of the 18th January, 1892.

22nd March 1892.—No. 917.—The furlough for one year granted, to Mr. A. A. Watson, Assistant Conservator of Forest, Southern Circle, under Notification No. 856, dated the 12th February, 1891, has been commuted to leave on medical certificate for fifteen months by Her Majesty's Secretary of State for India.

8—BURMA GAZETTE.—

16th March 1892.—No. 95.—Under the provisions of section 6 of the Burma Forest Act, 1881, the Chief Commissioner appoints Mr. P. A. Hauxwell, Deputy-Conservator of Forests, Salween-Ataran division, to be the Forest Officer to assist the Forest Settlement Officer in the enquiry ordered in this department Notification No. 243, dated the 14th October, 1891.

17th March 1892.—No. 93.—Under the provisions of Article 369 of the Civil Service Regulations leave on medical certificate for six months is granted to Maung Shwe Ka, Extra Assistant Conservator of Forests, with effect from the 19th November, 1891.

14th March 1892.—No. 4.—With reference to the Revenue Department Notification No. 65 (Forests), dated 26th ultimo, Mr. F. J. Branthwaite, officiating Deputy Conservator of Forests, relinquished charge of his duties as Personal Assistant to the Conservator of Forests on the afternoon of the 29th idem and proceeded to Toungoo to relieve Mr. H. A. Hoghton of the charge of that division.

No. 5.—With reference to Revenue Department Notification Nos. 64 and 65 (Forests), dated 26th ultimo, Mr. H. A. Hoghton, Deputy Conservator of Forests, made over and F. J. Branthwaite, officiating Deputy Conservator of Forests, assumed charge of the Toungoo division on the afternoon of the 3rd instant.

9.—ASSAM GAZETTE.—

4th March 1892.—No. 1840G.—The following is published

The undermentioned officer has been granted by Her Majesty's Secretary of State for India extension of leave as advised in list dated the 5th February 1892.

Mr. A. J. Mein ... Deputy Conservator of Forests, Assam. One year's furlough.

10th March 1892.—No. 1977G.—In partial modification of Notification No. 5786G., dated the 10th July, 1891, published at page 367 of the *Assam Gazette* of the 11th idem, the following promotions are made :

With effect from the 1st May, 1891—

Mr. H. G. Young, Assistant Conservator of Forests, First Grade, to officiate as Deputy Conservator, Fourth Grade, *vice* Mr. C. G. D. Fordyce.

With effect from the 7th May, to 13th June, 1891—

Mr. C. P. Fisher, Assistant Conservator, First Grade, to officiate as Deputy Conservator, Fourth Grade, *vice* Mr. D. P. Copeland.

16th March 1892.—No. 1022R.—In exercise of the powers conferred by sections 13 and 14 of Act VII of 1878. (The Indian Forest Act), the Chief Commissioner of Assam is pleased to make, and with the sanction of the Governor-General in Council to publish, the following Rules for the Makum Protected Forest in the district of Lakhimpur, which shall come into force on and from the 31st March, 1892 :

- I. No person shall cut, collect, or remove any forest produce, make clearance, pasture cattle, or allow cattle to graze, save under and subject to the conditions of a license.
- II. Such licenses may be granted by Forest Officer in charge of the Forest Division, or any other Forest or Revenue Officer authorised by him to grant such licenses. Such licenses are not transferable, and shall be issued in the forms appended to these rules.

III. Any Forest Officer or Police Officer may demand the production of any license alleged to be held for the cutting, collection, or removal of forest produce, the making of clearances, or the pasturing of cattle, and for such purpose may stop any forest produce in transit within, or passing the limits of, the Makum protected forest.

2. The above rules will not affect the rights to which the Assam Railways and Trading Company, Limited, are entitled under the two Concessions granted by the Government to the Company, *viz.*, the Coal Concession, dated the 30th July, 1881, and the Oil Concession, dated 16th December, 1882.

11.—MYSORE STATE GAZETTE.—

16th March 1892.—No. 481.—Mr. Y. Sitaramaiya, Assistant Conservator of Forests, Mysore District, who was granted 8 days casual leave in Notification No. 449, dated 13th February, 1892, having availed himself of only 6 days' thereof, from 6th to 11th February, 1892, both days inclusive, the unexpired portion, *viz.*, 2 days, is hereby cancelled.

VIII.—EXTRACTS FROM OFFICIAL GAZETTES.

1.—GAZETTE OF INDIA.—

6th April, 1892.—*No. 404 F.*—With reference to the Notification of this Department, No. 1348-F, dated the 29th December last, the transfer of Mr. W. M. Green, Deputy Conservator of Forests, 3rd Grade, from Bengal to Burma is cancelled.

No. 407-F.—With reference to the Notification of this Department, No. 1348-F., dated the 29th December last, the transfer of Mr. E. G. Chester, Deputy Conservator of Forests, 2nd Grade, from the Andamans to Bengal is deferred till further orders.

No. 410-F.—In continuation of the Notification of this Department, No. 1210-F., dated the 30th October, 1891, the services of Mr. E. P. Popert, Conservator of Forests, are placed permanently at the disposal of the Government of Madras, with effect from 17th January, 1892.

2.—MADRAS GAZETTE.—

29th March 1892.—*No. 125.*—Mr. C. G. Douglas, Deputy Conservator of Forests, First Grade, is granted Furlough on medical certificate for one year and six months, under article 340 (a) Civil Service Regulations.

23rd March 1892.—The privilege leave granted to Forest Ranger A. S. Mariapragasam Pillai in Service Order No. 30 of 1892, is extended by one month.

The privilege leave granted to Forest Ranger T. C. Malaya Pillai in Service Order No. 31 of 1892, is extended by two months.

5th March 1892.—*No. 134.*—Mr. F. C. L. Cowley-Brown Assistant Conservator of Forests, is posted to the Salem District, with effect from 1st April, 1892.

3.—BOMBAY GAZETTE.—

6th April, 1892.—*No. 3243.*—His Excellency the Governor in Council is pleased to appoint—

Mr. R. C. Wroughton to act as Conservator of Forests, Southern Circle, during the absence of Mr. J. L. Laird-MacGregor, or pending further orders;

Mr. F. Gleadow to act as Divisional Forest Officer, Poona, vice Mr. R. C. Wroughton, pending further orders;

Mr. R. P. Ryan to hold charge of the office of Divisional Forest Officer, Dhárwár, in addition to his own duties, pending Mr. Hight's return from leave.

12th April, 1892.—*No. 3370.*—Mr. L. S. Osmaston, Assistant Conservator of Forests, Second Grade, and Divisional Forest Officer, South Thána, passed with credit an examination in Maráthi according to the Higher Standard on the 7th instant.

20th April, 1892.—No. 1711.—Mr. Waman Ramchandra Gaunde, Extra Assistant Conservator of Forests, Poona, is allowed privilege leave of absence for three months from 5th May, 1892.

4.—BENGAL GAZETTE.

2nd April, 1892.—No. 1365F.—In Notification, No. 3861 F., dated the 21st December, 1891, published at page 1077 of the *Calcutta Gazette* of the 23rd idem, posting Mr. C. C. Hatt, Assistant Conservator of Forests, to the Jalpaiguri Forest Division, strike out the words “for special duty in connection with the preparation of Working Plans.”

12th April, 1892.—No. 1297F.—With the previous sanction of the Governor-General in Council, the Lieutenant-Governor is pleased to order that the following rule be substituted for Rule I of the rules made under sections 31 and 41 of the Indian Forest Act for the Sundarban Protected Forests, published in the Notification of the 5th November, 1888, at page 941, Part I of the *Calcutta Gazette* of the 7th idem, and that the revised rates now fixed shall have effect from the 1st July, 1892.

Rule 1.—No trees, timber, or any other forest produce shall be cut, sawn, gathered, or removed from the Sundarban Protected Forests without prepayment in full of the charges due thereon at the undermentioned rates, and in accordance with the following classification :—

(a).—Timber of the following kinds in pieces measuring eight feet and upwards in length, or three feet and upwards in girth at the thick end, shall be classed as *logs* and charged for as follows :—

Sundri—One-and-a-quarter annas per “running foot.”

Pussur and *Amoor*—One anna per running foot.

Logs of any other species—One-half anna per running foot.

Pieces of wood measuring eight feet and upwards in length, and under three feet in girth at the thick end, shall be classed as *poles* and charged for as follows :—

<i>Sundri</i> —One anna per maund	} Boat measurement.
<i>Pussur</i> , <i>Amoor</i> , and <i>Goran</i> —Nine pies per maund	
Poles of any other species—Six pies per maund	

Pieces of wood measuring less than eight feet in length, and of which the girth at the thick end is under three feet, shall be classed as *firewood*, and be charged for as follows :—

<i>Sundri</i> —Nine pies per maund	} Boat measurement.
<i>Goran</i> —Six pies per maund	
Other kinds of firewood—Three pies per maund	

In the event of any *Sundri* wood being found to be present in a boat-load of fuel of other kinds, the whole quantity of wood in the boat shall be liable to the higher royalty prescribed in the case of *sundri* firewood.

Wax and *Honey*—One rupee per maund.

All other forest produce—Three pies per maund ... Boat measurement.

(b).—These, and such other charges as may from time to time be fixed under sections 31 and 41 of the Act, shall also be levied on such timber and other forest produce as may be exported from lands leased under the rules for the lease of waste lands in the Sundarban.

5.—N.-W. P. AND OUDH GAZETTE.—

30th March 1892.—No. 1330.—Mr. L. Mercer, Officiating Deputy Conservator of Forests, from the charge of the Saháranpur Forest Division of the School Circle, to that of the Ganges Forest Division of the Central Circle.

30th March 1892.—1335.—Mr. A. P. Grenfell, Assistant Conservator of Forests, Jaunsár Forest Division, to the charge of the Saháranpur Forest Division of the School Circle.

No. 1339.—Mr. M. Hill, Officiating Deputy Conservator of Forests, from the charge of the Gorakhpur Forest Division, to that of the Kheri Forest Division of the Oudh Circle.

4th April 1892.—No. 281F.—In exercise of the power conferred by section 75 of the Indian Forest Act (VII) of 1878, and in super-session of Notification No. 395F, dated 27th May, 1889, the Hon'ble the Lieutenant-Governor of the North-Western Provinces and Chief Commissioner of Oudh, is pleased to make the following rules, to have effect in the Government reserved forests of the Kheri, Babraich and Gouda districts of Oudh :—

Rules for the regulation of grazing, and collection of dues therefor, from the "privileged" villages adjoining the reserve forests in Oudh.

Rule I.—Unless a village agrees, as a whole, to make use of the reserved forest, none of the cattle belonging to it will be allowed to graze in the same.

Rule II.—Grazing dues must be levied according to the rates fixed by Government (and shown in Appendix II to these rules) on all the cattle in each village which makes use of the reserved forest for grazing purposes. Provided that the Forest Officer shall exempt the cattle of any owners which, in his opinion, never graze in the Government forests.

Rule III.—The grazing year lasts from the 1st of October, of one year to the 30th September of the next : cattle born within the grazing year are exempt from dues for the said year.

Rule IV.—Before the end of September in each year the patwari of every village which elects, under Rule II, to graze its cattle in the forests, will furnish to the Tahsildár a nominal list (countersigned by the head-man of the village) of the cattle-owners in his village and the number of animals of each kind that each possesses, and the name of the herdsman (see Rules V and XIV) in whose charge they will be grazed : these lists will be at once sent direct to the Forest Officer, to be checked in such way and by such subordinate as he may direct.

"Head-man" includes the lambardár of the village, or, if the lambardár is non-resident, the thikadár, *sirwar* or agent representing him.

Rule V.—The checking by the Forest Department must be completed by the end of October, but the Forest Department reserves to itself the right of counting the cattle at any time during the year on the appearance of sufficient cause. The checking officer will also give to each herdsman a permit in the printed form in Appendix I or such other form as may be deemed advisable.

Rule VI.—The checking officer will give each cattle-owner a slip signed by him and also by the head-man when the checking has

brought out any difference from the numbers shown in the original list, with date, giving number of each kind of cattle, rates of assessment, and amount of dues. Within 15 days of receipt of such slip the cattle-owner may present his objection on plain paper, to the Forest Officer, who will fix dates for hearing and disposing of such objections, as far as possible, on the spot.

Rule VII.—The lists, having been checked and objections disposed of by the Forest Officer, will be sent by the Forest Officer to the Deputy Commissioner by the 30th of November. The Deputy Commissioner shall send the approved lists to the Tahsildars, who will make over the mauzawar extracts to the head-men (who are appointed by these rules to collect the dues) for collection forthwith. The Deputy Commissioner shall at the same time fix the date on which any sum not collected shall become an arrear (being not less than two months from date of order and not before the last day of February), and the same date shall be inserted in the mauzawar extracts made over to the head-man. Each head-man will be provided with a receipt book in a printed form, and he will give each cattle-owner a receipt from this book, in which will be stated the name of the owner, the number of cattle of each kind paid for, the amount paid, and the year for which the payment has been made. The receipt forms in each book must be serially numbered before issue to the head-man. The owners are bound to produce the receipts at their villages whenever called upon to do so by an officer of the Forest Department. After the collection has been completed, the head-man will hand in the pass-book containing counterfoils to the Tahsildar, who will forward it to the Forest Officer.

Rule VIII.—For all payments made by head-men into the tahsil, the Tahsildar will grant dakhilas in the same way as for all other money received, and will send to the Deputy Commissioner a quarterly account showing the amount assessed, the amount collected and the balance due.

Rule IX.—All sums not paid by the date fixed by the Collector under Rule VII. will be considered as arrears, and will be recovered in the same way as arrears of land revenue direct from cattle-owners.

Rule X.—Any cattle-owner whose name has been entered in the nominal list prepared under Rule IV, who is found grazing cattle in the Government forests after the date fixed by the Collector under Rule VII, for the payment of grazing dues, without having paid his grazing dues for the current year, and without having obtained the receipt referred to in Rule VII, will have to pay double rates and will be liable to prosecution.

Rule XI.—Any complainant dissatisfied with the Forest Officer's decision under Rule VI may petition the Deputy Commissioner on paper stamped with an eight-anna stamp, and the Deputy Commissioner's decision will be final. Should the decision be adverse to the Forest Department, that Department will pay the value of stamp to the complainant.

Rule XII.—Intimation of any decision by the Forest Officer or Deputy Commissioner effecting an alteration in the assessments must be given at once to the Tahsildar, who will inform the head-man and patwari of the complainant's village.

Rule XIII.—As soon as the Deputy Commissioner has realised the full amount of the assessments finally settled, he will send in a bill to the Forest Department for the percentages due on the collections, as follow :—

Head-man at $2\frac{1}{2}$ per cent. on amount collected.

Patwari at 1 per cent. on total collections.

Itlāq-navīs (or other tahsil official employed to keep the accounts) at half per cent.

Rule XIV.—Every single herd must have an adult herdsman (that is, a person of over 16 years of age) in charge. A herd consists of 100 or less head of cattle, bulls or bullocks, &c., or 50 buffaloes. In mixed herds a buffalo counts as two cows, &c. For every extra 50 or fraction of 50 there must be an additional herdsman not under 12 years of age. Every adult herdsman will carry with him in the forests the pass given by the checking officer, and will produce it to any Forest Officer desiring him to do so. The additional herdsmen will always carry with them the passes for the smaller extra numbers.

APPENDIX I.

(Front.)

Oadh Forests. Grazing permit. Privileged village (consecutive Serial No.—).

(Back).

District	Herdsman's name and number
Range	Number of buffaloes
Village	Number of cows

NOTE.—If any other cattle but buffaloes and cows, &c., are to be grazed, these will be entered in manuscript either below the name of buffaloes or cows, or in place of them.

APPENDIX II.

The following are the rates sanctioned by Government for grazing by privileged villages for the grazing year :—

	Rs.	a.	p.
Camels	0 8 0
Buffaloes	0 4 0
Cows, bulls, bullocks, &c.	0 2 0
Sheep and goats	0 0 6
Ponies or donkeys	0 1 0

10th April 1892.—No. 1534.—The Notification from this Department, No. 1335, dated the 30th March, 1892, appointing Mr. A. P. Grenfell to the charge of the Sahāranpur Forest Division, is hereby cancelled.

No. 1543.—Mr. B. B. Osmaston, Officiating Deputy Conservator of Forests, attached to the Direction Division of Central Circle as Working Plans Officer, to the charge of the Ganges Division in the same Circle, in addition to his own duties, during the absence on leave of Mr. E. A. Down, or until further orders.

No. 1538.—The Notification from this Department No. 1330, dated the 30th March, 1892, transferring Mr. L. Mercer, Officiating Deputy Conservator of Forests, from the charge of the Sahāranpur Forest Division of the School Circle, to that of the Ganges Forest Division of the Central Circle, is hereby cancelled.

18th April 1892.—No. 1593.—Pandit Keshavanand, Extra Assistant Conservator, attached to the Kheri Forest Division, to hold charge of the current duties of the office of Deputy Conservator of Forests, Kheri Division, in addition to his own duties, with effect from the 9th March, 1892, and until further orders.

19th April 1892.—No. 897.—Under section 14 of Act X of 1882, Mr. M. Hill, Officiating Deputy Conservator of Forests, is appointed a Special Magistrate, and is invested with the powers of a Magistrate of the 3rd class within the limits of any Forest Division of which he may be in charge, for the trial of offences punishable under Act VII of 1878.

20th April 1892.—No. 923.—Under section 14 of Act X of 1882, Mr. W. Shakespear, Deputy Conservator of Forests, is appointed a Special Magistrate, and is invested with the powers of a Magistrate of the 3rd class, within the limits of any Forest Division of which he may be in charge, for the trial of offences punishable under Act VII of 1878.

6.—PUNJAB GAZETTE.—

8th April 1892.—No. 181. *Notification.*—Messrs. A. M. Reuther and A. E. Wild, Deputy Conservators of Forests, respectively made over and assumed charge of the Hazara Forest Division on the forenoon of the 26th March 1892.

Mr. A. M. Reuther will remain attached to the Hazara Division till further orders.

7.—CENTRAL PROVINCES GAZETTE.—

29th March 1892.—No. 1008.—Mr. W. King, Deputy Conservator of Forests, having reported, on the 8th ultimo, his return from the furlough granted him by Notification No. 7128, dated the 10th November 1890, is posted to the Narsinghpur Forest Division.

No. 1009.—On being relieved by Mr. W. King, of the charge of the Narsinghpur Forest Division, Mr. Chunder Kumar Chatterji, Extra-Assistant Conservator of Forests, is transferred to the Hoshangabad Forest Division.

No. 1010.—Messrs. Chunder Kumar Chatterji and W. King respectively made over and received charge of the Narsinghpur Forest Division on the forenoon of the 11th February 1892.

No. 1012.—With reference to Notification No. 1,009 dated 29th March 1892, Mr. Chunder Kumar Chatterji, Extra-Assistant Conservator of Forests, assumed charge of his duties in the Hoshangabad Forest Division on the forenoon of the 30th ultimo.

30th March 1892. No. 1023.—Mr. Ramchandra, Sub-Assistant Conservator of Forests, Chanda, is granted privilege leave for twenty-five days, under Article 291 of the Civil Service Regulations, with effect from the 12th February 1892.

No. 1024.—Mr. Ramchandra, Sub-Assistant Conservator of Forests, Chanda, availed himself of the twenty-five days' privilege leave granted him by Notification No. 1023, dated the 30th March 1892, on the forenoon of the 12th February 1892, and resumed charge of his duties on the afternoon of the 7th March 1892.

8.—BURMA GAZETTE —

18th March 1892. No. 100.—In exercise of the power conferred by section 34 of the Upper Burma Forest Regulation, 1887, the Chief Commissioner makes the following rule in supersession of the rule published in Revenue Depart. Notification No. 143, dated the 1st July 1892 :—

Rule 16 (c).—The felling or girdling for trade purposes of pyinma, pyinkado, ingyng, thiyitya, or thitsi trees on land at the disposal of Government and not included in reserved forest or a village forest, within limits of the Pyinmana, Yamethin, Katha, Shwebo, Ye-u, Magwe, and Minbu districts is prohibited, except under and subject to the conditions of a license issued by the officer in charge of the Forest division concerned.

24th March 1892. No. 103.—Mr. P. J. Carter, Officiating Conservator of Forests, Pegu Forest Circle, was placed in charge of the Teuasseim Forest Circle as a temporary measure in addition to his other duties during the absence of Major Bingham on deputation under the orders of the Government of India.

Mr. Carter received charge of the Tenasserrim Forest Circle from Major Bingham on the afternoon of the 4th March 1892.—

28th March 1892. No. 110.—For the purposes of the Burma Forest Act, 1881, and the Rules thereunder, the Chief Commissioner is pleased to appoint Extra-Assistant Conservators of Forests in Lower Burma to be Sub-Assistant Conservators of Forests, with effect from the 17th November 1891.

No. 111.—For the purposes of the Upper Burma Forest Regulation, 1887, and the rules thereunder, the Chief Commissioner is pleased to appoint Extra-Assistant Conservators of Forests in Upper Burma to be Sub-Assistant Conservators of Forests, with effect from the 17th November 1891.

No. 112.—With the sanction of the Government of India, the Chief Commissioner directs that the Upper Burma Forest Circle shall be divided into two Circles, to be known as the Eastern and Western Circles respectively.

The Eastern Circle will be composed of the following Forest divisions :—

Bhamo.		Mu.
Mandalay.		The Southern Shan States on
Pyinmana.		the Salween drainage.
Katha.		

The Western Circle will be composed of the following Forest divisions :—

Minbu.		Chindwin.		Yaw.
--------	--	-----------	--	------

No. 113.—With reference to this department Notification No. 112 dated the 28th March 1892, and with the sanction of the Government of India, the following postings are ordered :—

Mr. J. W. Oliver Conservator of Forests, to the charge of the Eastern Forest Circle, Upper Burma, with his headquarters at Mandalay.

Mr. T. H. Aplin, Deputy Conservator of Forests, to the charge of the Western Forest Circle, Upper Burma, with his headquarters at Mandalay.

No. 114.—Mr. A. M. Burn-Murdoch, Assistant Conservator of Forests, is transferred from Yamethin to the charge of the Minbu Forest division as a temporary measure.

No. 115.—Under the provisions of section 4 (2) of the Upper Burma Regulation, 1887, the Chief Commissioner appoints Mr. A. M. Burn-Murdoch, Assistant Conservator of Forests, Minbu, to succeed Mr. T. H. Aplin as the Forest Officer who shall assist the Forest Settlement Officer in the enquiry ordered in this department Notification No. 250, dated the 13th October 1891.

29th March 1892. 116.—Under the provisions of Article 291, Civil Service Regulations, privilege leave for three months and 15 days is granted to Mr. H. B. Ward, Deputy Conservator of Forests, with effect from the 11th April 1892, or the subsequent date on which he may avail himself of it.

No. 117.—Mr. W. F. L. Tottenham, Assistant Conservator of Forests, is transferred from Rangoon to the charge of the Western Forest division during the absence on privilege leave of Mr. H. B. Ward Deputy Conservator of Forests, or until further orders.

30th March, 1892.—No 118.—In supersession of this department Notification No. 102, dated the 23rd March 1892, the Chief Commissioner appoints Lieutenant E. C. Townsend, Assistant Commissioner, to succeed the Deputy Commissioner, Pegu district, as the Forest Settlement Officer who shall hold the enquiry ordered in this Department Notification No. 254, dated the 27th October 1891.

12th April, 1892.—No, 129.—(Corrigendum).—In this department Notification No. 36, dated the 9th February 1892, in which was published a revised form of license to possess and carry marking-hammers, for "this department Notification No. 84 (Forests), dated the 12th June, 1890," read "this department Notification No. 11, dated the 10th January.

14th April, No. 131 (Corrigendum).—In this department Notification No. 114, dated the 28th March 1892, for "Yamethin" read "Taungdwingyi."

No. 132.—With reference to Rule 18 of of the Rules under the Burma Forest Act, 1881, the Chief Commissioner, under the provisions of section 43 (g) of that Act, sanctions the addition of Chaung-hna-gwa at the junction of the Zami and Winyaw streams on the Attaran river, Amherst district, to the list of stations to which timber in transit shall be taken by those in charge of it for examination and for the realization of any money payable to Government in respect thereof or in order that any mark may be affixed thereto.

No. 133.—Major C. T. Bingham, Officiating Conservator of Forests, resumed charge of the Tenaeserim Forest Circle on the 13th April, 1892 afternoon.

20th April, 1892.—No. 134.—Mr. C. W. A. Bruce, Assistant Conservator of Forests, is transferred from Mandalay to the charge of the Minbu Forest Division.

No. 135.—On being relieved of the charge of the Minbu Forest Division by Mr. C. W. A. Bruce, Mr. A. M. Burn-Murdoch, Assistant Conservator of Forests, is transferred from Minbu to the charge of the Taungdwingyi sub-division of the Minbu Forest division, and will continue, in addition to this own duties, to assist the Forest Settlement Officers in the enquiry referred to in this department Notification No. 115 dated the 28th March, 1892.

9.—ASSAM GAZETTE.—

31st March, 1892.—No. 2568G.—The following is published :

The undermentioned officer has been granted by Her Majesty's Secretary of State for India, permission to return to duty within the period of his leave as advised in list dated the 12th February, 1892 :

Mr. J. E. Barrett	..	Assistant Conservator of Forests, Assam.
-------------------	----	---

11.—MYSORE STATE GAZETTE.—

1st April, 1892 —No. 1.—Mr. B. Srinivasa Rao, Sub-Assistant Conservator of Forests, Tumkur District, reported himself for special duty in the Chitaldroog District, on the forenoon of the 12th ultimo.

21st April, 1892.—No. 137.—Mr. E. A. O'Bryen, Assistant Conservator of Forests, is transferred from Bhamo to the charge of the Katha forest division.

No. 138.—Under the provisions of Article 340 (b) of the Civil Service Regulations, Mr. E. S. Carr, Deputy Conservator of Forests, is granted furlough to Europe for one year and seven months, with effect from the 1st May, 1892, or the subsequent date on which he may avail himself of it.

No. 139.—In exercise of the power conferred by section 34 of the Upper Burma Forest Regulation, 1887, the Chief Commissioner directs that the following rule shall be added to the rules published under Revenue Department Notifications No. 59, dated the 11th April, 1889:—

17c.—A duty at the rate of 8 annas per 100 cubic feet stacked shall be paid on all firewood, being the produce of land at the disposal of Government, used by steamers, launches, railways, or factories in Upper Burma. Such duty shall be paid before the firewood is utilized. Consumers may, subject to the sanction of the Conservator of Forests, take out prepaid licences in the form of Appendix XIV to these rules for the total quantity of firewood to be consumed during any fixed period not exceeding one year. The fee for prepaid licenses shall be calculated at the rate of Rs. 4 per 1,000 cubic feet stacked.

APPENDIX XIV.

Prepaid License for Firewood

LICENSE to utilize cubic feet of firewood during the period from the to the has been granted under the Upper Burma Forests Rules to on payment of Rs. being at the rate of Rs. 4 per 1,000 cubic feet of firewood stacked, subject to the following conditions:—

- (i) that this license is not transferable;
- (ii) that this license does not exempt the holder from the payment of duty on firewood brought into Mandalay.

Breach of condition (i) of this license will render the license liable to forfeiture, and the holder thereof to the punishment provided in the Forest rules.

No. 140.—Under Rule 16 of the Rules under the Upper Burma Forest Regulation, 1887, and in modification of Revenue Department Notification No. 62 (Forests) dated the 11th April, 1889, the Chief Commissioner directs that, with effect from the date of this Notification, firewood brought into Mandalay shall be liable to a duty of 8 annas per 100 cubic feet stacked, instead of the rates prescribed in that Notification.

14th April, 1892.—No. 3.—With reference to Revenue Department Notification No. 114 (Forests), dated Rangoon, the 28th March, 1892, Mr. A. M. Burn-Murdoch, Assistant Conservator of Forests, received charge of the Minbu division from Mr. T. H. Aplin on the afternoon of the 8th April, 1892.

20th April, 1892.—No. 6.—With reference to Revenue Department Notification No. 117 F., dated the 29th March, 1892, Mr. H. B. Ward, Deputy Conservator of Forests, made over, and Mr. W. F. L. Tottenham, Assistant Conservator of Forests, received charge of, the Western division on the afternoon of the 15th instant.

VIII.—EXTRACTS FROM OFFICIAL GAZETTES.

1.—GAZETTE OF INDIA.

27th April, 1892.—No. 492-F.—The services of Mr. A. F. Broun, Deputy Conservator of Forests, Burma, are placed permanently at the disposal of the Government of Ceylon, with effect from 28th December, 1891.

4th May, 1892.—No. 524F.—Mr. T. H. Aplin, Deputy Conservator of Forests, Burma, is appointed to officiate as Conservator, 3rd grade, in charge of the Western Circle in Upper Burma, with effect from the 15th April, 1892, and until further orders.

6th May 1892.—No. 526F.—The following promotions are made among Conservators of Forests, with effect from the dates specified :

(a) Consequent on the retirement from the service of Colonel W. J. Seaton, Conservator, 1st grade.

- | | | |
|---|---|---------------------|
| <ul style="list-style-type: none"> (i) Colonel G. J. Van Someren, Conservator, 2nd grade, to the 1st grade. (ii) Mr. C. Bagahawe, Conservator, 3rd grade to the 2nd grade. (iii) Mr. S. Eardley Wilmot, Deputy Conservator, 3rd grade, and Officiating Conservator, 3rd grade, is confirmed in the latter appointment, and will officiate in the 2nd grade until further orders. | } | 10th October, 1891. |
|---|---|---------------------|

(b) Consequent on the permanent transfer to the Madras Presidency of Mr. E. P. Popert, Conservator, 2nd grade—

- | | | |
|--|---|--------------------|
| <ul style="list-style-type: none"> (i) Mr. R. H. C. Whittall, Conservator, 3rd grade to the 2nd grade. (ii) Mr. A. E. Wild, Deputy Conservator, 1st grade, and Officiating Conservator, 3rd grade, is confirmed in the latter appointment, and will officiate in the 2nd grade until further orders. | } | 17th January 1892. |
|--|---|--------------------|

(c) Consequent on the retirement from the service of Colonel Van Someren, Conservator, 1st grade—

- | | | |
|---|---|---------------------|
| <ul style="list-style-type: none"> (i) Mr. J. S. Gamble, Conservator, 2nd grade, and officiating in the 1st grade, is confirmed in the latter grade (ii) Mr. E. P. Dansey, Conservator, 3rd officiating 1st) grade, to the 2nd grade, but to continue to officiate in the 1st grade until further orders, (iii) Mr. P. J. Carter, Deputy Conservator, 2nd grade, and Officiating Conservator, 3rd grade, is confirmed in the latter appointment, and will officiate in the 2nd grade until further orders. | } | 1st February, 1892. |
|---|---|---------------------|

6th May, 1892.—No. 532F.—The undermentioned officers, who have been appointed by Her Majesty's Secretary of State to the Forest Department of India, are appointed to be Assistant Conservators of the 2nd grade, with effect from the dates specified opposite their names, and are posted to the provinces noted below :

Mr. F. A. Leete, North-Western Provinces and Oudh,—5th January, 1892.

„ S. Carr, Burma—8th January, 1892.

„ J. C. Tulloch, North-Western Provinces and Oudh,—5th January, 1892

„ H. S. K. Edie, Central Provinces,—31st December, 1891.

„ C. C. Hatt, Bengal,—3rd January, 1892.

„ F. Trafford, Bengal,—7th January, 1892.

„ A. M. Long, Assam,—4th January, 1892.

13th May, 1892.—No. 550F.—With reference to the Notification of this Department, No 1348F, dated the 29th December last, Mr. A. M. Reuther, Deputy Conservator of Forests, 4th grade, is retransferred from Assam to the Punjab, with effect from 2nd March, 1892.

17th May, 1892.—No. 571F.—On return from furlough, Mr. R. H. C. Whittall, Conservator of Forests, 2nd grade, resumed charge of the Punjab Forest Circle from Mr. A. E. Wild, Conservator, 3rd (officiating 2nd) grade, with effect from 18th March 1892, and is appointed to officiate in the 1st grade of Conservators from the same date, and until further orders.

In consequence of Mr. Whittall's return, Mr. J. W. Oliver, Conservator, 3rd (officiating 1st) grade, Burma, reverted from officiating in the 1st grade of Conservators with effect from 18th March 1892, but will officiate in the 2nd grade from the same date, and until further orders.

Mr. Wild, Conservator, 3rd (officiating 2nd) grade, was deputed to special duty in the Punjab from 18th March, to 24th April, 1892, both dates inclusive.

No. 575F.—Mr. A. E. Wild, Conservator of Forests, 3rd (officiating 2nd) grade, is appointed to the charge of the Central Circle, North-Western Provinces and Oudh, with effect from 25th April, 1892, and until further orders.

20th May, 1892.—No. 608F.—In supersession of the Notification of this Department, No. 739F., dated 26th June, 1891, and in partial modification of Notification No. 1348F., dated 29th December, 1891—

(i) Mr. E. E. Fernandez, Deputy Director of the Forest School, Dehra Dún, is appointed Deputy Conservator, 1st grade, in Assam, with effect from 26th February, 1891, but continued to be Deputy Director of the Forest School up to 24th May, 1891 (*seconded*), and has been on deputation to the Baroda State since 25th idem (*seconded*).

(ii) Mr. J. T. Jellicoe, officiating 1st grade Deputy Conservator in Assam, to be Deputy Conservator, 1st grade, sub. *pro tem*, vice Mr. Fernandez, with effect from 26th February 1891, and upon 29th December, 1891, from which latter date he will be appointed a permanent Deputy Conservator 1st grade, in Burma.

No. 612F.—The following transfers are made in the interests of the public service :

- (i) Mr. J. L. Pigot, Deputy Conservator of Forests, 4th grade, Central Provinces, and Assistant Inspector General of Forests and Superintendent of Working Plans (*seconded*), to Assam as Deputy Conservator, 3rd grade, but to continue as Assistant Inspector General of Forests and Superintendent of Working Plans (*seconded*), with effect from 2nd March 1892.
- (ii) Mr. R. H. M. Ellis, officiating 1st grade Deputy Conservator, Bengal, to Assam as Deputy Conservator, 1st grade, sub. *pro tem.*, with effect from 16th May, 1892.
- (iii), Mr. C. G. D. Fordyce, Deputy Conservator, 3rd grade, Assam, to Bengal, with effect from 16th May 1892.

No. 617F.—*Erratum*—In the Notification of this Department, No. 1041F., dated 19th December, 1890, promoting Colonel J. E. Campbell to the 1st grade of Deputy Conservators of Forests, *vice* Mr. Brereton, retired, for “with effect from the 18th November, 1890” read “with effect from the 13th December 1890.

2.—MADRAS GAZETTE.—

8th April, 1892.—R. Venkatesa Mudali, Forest Ranger, Kurnool, is granted fifteen days' privilege leave, with effect from such date as he availed himself of the same.

3rd May, 1892, No. 155.—Mr. A. W. Peet, Conservator of Forests, Second Grade, has been granted by the Right Honorable the Secretary of State for India an extension of six months' furlough, in continuation of the leave notified at page 99, Part I of the *Fort St. George Gazette*, dated 17th February, 1891.

No. 156.—Mr. A. W. C. Stanbrough, Deputy Conservator of Forests, Third Grade, and acting in the Second Grade, to act as Examiner of Forest Accounts until further orders.

No. 157.—Mr. C. J. Woutersz, Sub-Assistant Conservator of Forests, Second Grade, to act as District Forest Officer, South Arcot, during Mr. Stanbrough's absence on other duty, or until further orders.

24th April, 1892, *Examinations*.—The following is the result of the Final Examinations at the Forest School of the students of the Central Circle who attended the course of 1890-92:—

Forester Mr. F. A. Seager	...	}	Obtained Higher Standard certificate.
Forester Mr. W. H. Blacker	...		
Ranger Mr. R. S. Bower	...		Obtained Lower Standard certificate; also medal in Surveying.

Posting.—Mr. R. S. Bower, Forest Ranger, is posted to the Cuddapah District.

28th April, 1892, *Leave*.—V. P. Ramalingam Pillai, Ranger, on Rs. 125, is granted furlough, under article 271 of the Civil Service Regulations, for four months from such date as he may avail himself of it, which should be reported by the District Forest Officer.

8th April 1892, No. 178.—Kuppili Naraina Appadu, late a Forester, Kistina District, having been convicted of criminal misappropriation by a public servant under section 409 of the Indian Penal Code, is hereby declared ineligible for further employment in the public service.

8th May, 1892, Transfer.—Ranger Mr. R. S. Bower from Cuddapah to the Salem Forest District—to join at once.

18th May 1892, Promotion.—Mr. F. A. Seager, Forester, First Grade, North Arcot District, to be Ranger, Fifth Grade, with effect from 1st May, 1892.

Mr. W. H. Blacker, Forester, First Grade, North Arcot District, to be Ranger, Fifth Grade, sub. *pro tem.*, with effect from 1st May, 1892,

3.—BOMBAY GAZETTE.

18th April 1892.—Mr. C. Greatheed, Deputy Conservator of Forests, delivered over charge of the Divisional Forest Office, Colaba, to Mr. N. K. Thanedar, Huzur Deputy Collector, on the forenoon of the 1st instant.

Mr. T. R. D. Bell, Assistant Conservator of Forests, received charge from Mr. Thanedar on the forenoon of the 9th idem.

21st April 1892.—Messrs. F. Gleadow, Deputy Conservator, and R. P. Ryan, Assistant Conservator of Forests, respectively delivered over and received charge of the Dharwar Division on the afternoon of the 18th instant.

Mr. T. R. D. Bell, Deputy Conservator, gave over charge of the Divisional Forest Office, Working Plans Branch, Kanara, on the afternoon of 5th instant, to Mr. H. Mitra, Sub-Assistant Conservator, who gave it over to Mr. C. M. Hodgson, Assistant Conservator, on the afternoon of the 11th id. m.

25th April 1892.—Mr. Ganesh Sakharam Hingé, Third Grade Extra Assistant Conservator of Forests, West Khandesh, delivered over charge of his office and duties to Mr. E. G. Oliver, Divisional Forest Officer, West Khandesh, on the 12th current, in the afternoon, and proceeded on one month's privilege leave granted to him by the Conservator of Forests, N. C., under authority vested in him by Government Resolution No. 2149 dated 20th March, 1889.

27th April 1892.—Messrs. R. C. Wroughton, Divisional Forest Officer, Poona, and F. Gleadow, Divisional Forest Officer, Dharwar, respectively delivered over and received charge of the Divisional Forest Office, Poona, on the 21st current, before office hours.

29th April 1892.—Messrs. R. P. Ryan, Assistant Conservator of Forests, and G. A. Hight, Deputy Conservator of Forests respectively delivered over and received charge of the Divisional Forest Office, Dharwar, on the afternoon of the 27th April, 1892.

7th May 1892.—No. 3988.—His Excellency the Governor in Council is pleased to make the following appointments with effect from the retirement of Mr. Neribdas valad Jethmal :—

Mr. J. M. Fernandez to be First Grade Extra-Assistant Conservator of Forests ;

Mr. Haripad Mitra, L. C. E., to be 2nd Grade, Extra Assistant Conservator of Forests ;

Mr. J. Baptista, L.C.E., to be Third Grade Extra-Assistant Conservator of Forests ;

Mr. Krishnaji Bhabaji Phadke to be Fourth Grade Extra-Assistant Conservator of Forests.

2. Mr. J. Baptista, L.C.E., is transferred for service in the Sind Circle.

9th May, 1892.—No. 4002.—Narayan bin Rāghu, inhabitant of Mahim in the Thana Collectorate, and late a Forest Guard in the Mahim Range of the North Thana Division, having been convicted under Section 409 of Indian Penal Code, is hereby declared incapable of serving Government again in any capacity.

No. 4003.—Vishnu Sakbaram Bhade, inhabitant of Satara in the Satara Collectorate, and late a Forest Depot Officer in Malcompeth in the Satara Division, having been convicted under Section 409 of the Indian Penal Code, is hereby declared incapable of serving Government again in any capacity.

10th May, 1892.—No. 4052.—His Excellency the Governor in Council is pleased to appoint Mr. W. F. D. Fisher to do duty as Divisional Forest Officer, Panch Mahals, *vice* Mr. Keys, pending further orders.

11th May, 1892.—Mr. W. R. Gaunde, Extra-Assistant Conservator of Forests, Poona, handed over charge of the Sub-Division Office, Poona, to the Divisional Forest Officer, Poona, on the 4th May, 1892, after office hours, and proceeded on the privilege leave of absence for three months granted to him by Government Resolution No. 1711, dated 20th April, 1892, Financial Department.

16th May, 1892.—No. 4225.—His Excellency the Governor in Council is pleased to appoint Mr. G. M. Ryan to act as Deputy Conservator of Forests, Sind Circle, during the absence of Mr. W. S. Hexton on privilege leave, or pending further orders.

17th May, 1892.—No. 2069.—Mr. A. Stewart, Deputy Conservator of Forests, has been allowed by Her Majesty's Secretary of State for India to return to duty within the period of his leave.

19th May, 1892.—No. 2109.—Mr. T. R. D. Bell, Divisional Forest Officer, Kolaba and Ratnagiri, is allowed privilege leave of absence for three months with effect from 20th May, 1892.

20th May, 1892.—No. 4353.—His Excellency the Governor in Council is pleased to appoint Rao Bahadur Pandurang Daji Adhikari to be Deputy Collector, Third Grade, *vice* Rao Bahadur Yeshvant Moreshvar Kelkar, seconded, with effect from date of vacancy.

21st May, 1892.—No. 2142.—Mr. A. D. Wilkins, Deputy Conservator of Forests, Third Grade, and Divisional Forest Officer, Ahmednagar, is allowed privilege leave of absence for three months.

No. 4354.—His Excellency the Governor in Council is pleased to make the following appointments on the return of Mr. A. Stewart from leave :—

Mr. F. Gleadow to do duty as Professor of Forestry, College of Science ;

Mr. A. D. Wilkins to do duty as Divisional Forest Officer, Poona ;

Mr. A. Stewart to do duty as Divisional Forest Officer, Ahmednagar.

23rd May, 1892.—No. 4407.—His Excellency the Governor in Council is pleased to make the following appointments in modification of previous orders and in consequence of the grant of privilege leave to Mr. A. D. Wilkins :—

Mr. S. Hornidge, A.M.I.C.E., to take charge of the office of Divisional Forest Officer, Ahmednagar, in addition to be own duties, pending the arrival of Mr. A. Stewart ;

Mr. F. Gleadow to retain charge of the office of Divisional Forest Officer, Poona, pending Mr. Wilkins's return from leave, under-

taking the duties of Professor of Forestry at the College of Science in addition.

18th May 1892.—Messrs H. W. Keys, Deputy Conservator of Forests, and W. F. D. Fisher, Assistant Conservator of Forests, respectively delivered over and received charge of the office of the Divisional Forest Officer, Panch Manaf, on the 12th instant, after office hours.

4.—BENGAL GAZETTE.

3rd May, 1892.—No. 1737F.—In continuation of the Notification, dated the 9th April, 1891, published in the *Calcutta Gazette* of the 15th idem, the Lieutenant-Governor is pleased to notify that the following rules made under section 75 (d) of the Indian Forest Act, VII of 1878, for the prevention of fire, are in force in the district of Palamau in the Chota Nagpur Division. The season during which these rules will hold good will be from the 1st January, to the 1st July, in each year :—

1. Any person living in the vicinity of a Government Forest Reserve, or occupying or using land in such vicinity, and desirous of clearing by fire any standing forest or grass land near that Reserve, in a locality from which such fire would be likely to endanger the Reserve, shall observe the following rules :—

- (1)—He shall give notice of at least one week to the nearest Forest Officer, ranger, or forester of his intention.
- (2)—He shall clear a belt of land at least 20 feet broad on the side of the land which he proposes to burn nearest to the Forest Reserve.
- (3)—He shall choose for such burning a day or time when a high wind is not blowing.
- (4)—He shall light the fire in a direction contrary to the prevailing wind.

2. Any such person desirous of burning, on land adjoining a Forest Reserve, wood, grass, weeds, or other cut material, shall collect that material into heaps, and burn it separately in such a way that the fire may not endanger the Forest Reserve.

3. Any person collecting inflammable forest produce, such as grass and bamboos, on land adjoining a Forest Reserve, and any holder of a permit to collect such materials from the Forest Reserve, shall stack the materials so collected in an open space as far removed as possible from the forest.

4. All persons travelling on roads passing through or along the boundary of a Forest Reserve shall camp only at such places as may be cleared and set apart for the purpose of camping-grounds by the Forest Officer, who shall yearly publish a list of such grounds in the vicinity of the Reserve. Camping at other localities than those so set apart is forbidden; and all persons so camping shall light any fires they may make for cooking or other purposes in such a way as not to endanger the Forest Reserve, or the buildings or property on the camping ground, and they shall extinguish all such fires before leaving the camping ground.

5. The carriage of burning wood, fire-brands, or torches, through or along the boundary of any Reserved forest is prohibited.

15th May, 1892.—No. 1954F.—In supersession of all previous Notifications under this section, relating to the Protected Forests of the Khurda Government Estate in Orissa, the Lieutenant-Governor is pleased, under section 29 of the Indian Forest Act (VII of 1878) to—

(a) declare the following classes of trees to be reserved in the said forests from the date of this notification, namely.

- | | |
|---|--|
| 1. Mango ; vernacular <i>ám</i> (<i>Manji-fera indica</i>). | 8. Khendhu (<i>Diospyros melanoxylon</i>). |
| 2. Tamarind ; Vernacular Tentuli (<i>Tamarindus indica</i>). | 9. Hara (<i>Terminulia Chebula</i>). |
| 3. Mohul (<i>Bassia latifolia</i>). | 10. Gundi (<i>Mallotus philippinensis</i>). |
| 4. Jack ; vernacular Panasa (<i>Artocarpus integrifolia</i>). | 11. Kusum (<i>Schleichra trijuga</i>). |
| 5. Kuchila (<i>Strychnus nux-vomica</i>). | 12. Sonari (<i>Cassia Fistula</i>). |
| 6. Neem (<i>Melia indica</i>). | 13. Suam (<i>Soymida febrifuga</i>). |
| 7. Bel (<i>Ægle marmelos</i>). | 14. Sal (<i>Shorea robusta</i>). |
| | 15. Piasal (<i>Pterocarpus Marsupium</i>). |
| | 16. Sissu (<i>Dalbergia Sissoo</i> and <i>D. latifolia</i>). |

(b) prohibit in the said forests, subject to the rules made with the previous sanction of the Governor-General in Council, under section 31, the following acts, namely—

- (1) the quarrying of stone ;
- (2) the burning of lime and charcoal ;
- (3) the collection, or subjection to any manufacturing process, or removal of any forest produce ;
- (4) the breaking up or clearing of any land for cultivation, for building, for herding cattle, or for any other purpose.

10th May, 1892.—No. 1955F.—In supersession of all previous Notifications under this section relating to the Protected Forests of the Government Estate of Khurda in Orissa, the Lieutenant-Governor is pleased, under section 31 of the Indian Forest Act, (Act VII of 1878), and with the previous sanction of the Governor-General in Council, to make the following rules for the management of the said forests, namely :—

1. The Khurda Protected Forests shall be under the management of the officer in charge of the Puri Forest Division, acting under the orders of the Collector of Puri.

2. Green trees of the 16 species reserved under section 29 may not be felled, cut, lopped or in any way injured, without the written permission of the Collector of Puri in each case, and such permission will only be given in behalf of some public object. The material yielded by the operations can be disposed of as the Collector may decide but all revenues realized from this source must be credited to the Forest Department.

3. All trees and timber not belonging to the classes reserved under section 29 have been set aside for the use of the raiyats and other residents of the estate, and may not be felled, cut, collected or removed except as provided in these rules,

4. Trees of the following species may not be lopped, but may be felled and removed for purposes of house construction and repair, and for the manufacture and repair of household and agricultural implements and furniture :—

- | | |
|---|--|
| 1. Karam (<i>Adina cordifolia</i>). | 9. Tinia (<i>Albizzia</i>). |
| 2. Gambhari (<i>Gmelina arborea</i>). | 10. Mohini (<i>Odina Woodier</i>). |
| 3. Mohanim (<i>Ailanthus excelsa</i>). | 11. Kasi (<i>Briedelia retusa</i>). |
| 4. Chhariana (<i>Ochrocarpus longifolia</i>). | 12. Poonang (<i>Calophyllum inophyllum</i>). |
| 5. Bheru (<i>Chloroxylon Swietenia</i>). | 13. Bandan (<i>Ougeinia dalbergioides</i>). |
| 6. Korong (<i>Pongamia glabra</i>). | 14. Anan (<i>Terminalia tomentosa</i>). |
| 7. Dhan (<i>Anogeissus latifolia</i>). | 15. Bahera (<i>Terminalia belerica</i>). |
| 8. Kongora (<i>Xylocarpus dolabriformis</i>). | |

These trees are not to be cut for firewood, fencing material, or for any other purpose than that mentioned above, without the Collector's written sanction.

5. Subject to the conditions contained in Rule 4, trees not reserved under section 29, and dry trees and dry timber of all species, excepting sal, piasal and sissoo, and all other forest produce whatsoever, may be felled, cut, collected and removed by every *bonâ fide* resident of the Khurda Government estate, together with all members of the indigenous tribes known as Savars and Bouris, and all landless labourers to all which persons grazing also may be permitted, provided—

- (i) that the produce shall be required for personal use, and shall not be sold or bartered except to persons privileged under these rules, who will then be bound in the same way ;
- (ii) that a payment calculated at the rate of six pies in the rupee of his rent, or such other amount as may be fixed from time to time by the Local Government, shall be realized (in addition to the rent) by the Collector of Puri from every rent-paying raiyat in each village of the estate, and credited to the Forest Department as forest Revenue on account of general use of the Protected Forest ;
- (iii) that where the user is a dhobi, potter, blacksmith, or other person following some industry which consumes an unusually large quantity of fuel, such user shall obtain from the Divisional Forest Officer on annual license to be paid for at the rate of one rupee, or such other rate or rates as may be fixed from time to time by the Local Government ;
- (iv) that professional graziers of goats and sheep may only graze such animals in localities to be set aside for the purpose by the Collector of Puri, and that all professional graziers shall pay the following grazing fees, or such other fees as may be fixed from time to time by the Local Government :—

Per buffalo (of any age) ...	Eight annas per annum, or for any period of less than a year.
Any other animal (of any age)...	Four annas per annum, or for any period of less than a year.

6. No land in the Khurda Protected Forest may be cleared or broken up for "toila," i.e., temporary cultivation, except with the written permission of the Collector of Puri, and subject to the condition that trees of the species reserved under section 29 (including stems of any age) may not be felled, lopped, burnt, or in any way injured.

5.—NORTH-WEST PROVINCES AND OUDH GAZETTE.

25th April, 1892.—No. 1721, 11-349C.—Mr. P. A. Leete, Assistant Conservator of Forests, attached to the Garhwal Division of the Central Circle, on special duty, to the Naini Tal Division in the same circle, on special duty, with effect from the 1st May, 1892.

No. 1785, 2-350C.—Mr. E. L. Haslett, Extra-Assistant Conservator of Forests, attached to the Direction of the Central Circle, on special duty, to the Garhwal Division in the same circle, on special duty, with effect from the 1st May, 1892.

2nd May, 1892.—No. 1929, 2-83C.—Mr. L. Mercer, Officiating Deputy Conservator of Forests, Saharanpur Division, privilege leave for seventeen days, with effect from the 16th April, 1892, or subsequent date.

2nd May, 1892.—No. 1933, 2-276C.—Mr. A. P. Grenfell, Assistant Conservator of Forests, to the charge of the Saharanpur Forest Division of the School Circle, during the absence on leave of Mr. L. Mercer, or until further orders.

4th May, 1892.—No. 1988, 2-403C.—Mr. A. G. Hobart-Hampden, Deputy Conservator of Forests, Naini Tal Forest Division, held charge of the office of Conservator of Forests, Central Circle, in addition to his own duties, from the 3rd to the 24th April, 1892, both days inclusive.

5th May, 1892.—No. 2089, 2-267C.—Mr. A. P. Grenfell, Assistant Conservator of Forests, attached to the Jaunsar Forest Division, to the Saharanpur Division, to do duty under the Divisional Officer, with effect from the 1st April, 1892.

6.—PUNJAB GAZETTE.

21st May, 1892.—No. 246.—*Notification.*—In supersession of so much of *Punjab Government Gazette Notification No. 412*, dated October 4th, 1886, as is contained in the first six lines of the tabular statement of executive Forest charges thereto attached, the Hon'ble the Lieutenant-Governor directs that the executive Forest charges of Bashahr and Umballa be arranged hereafter as follows :—

Executive Forest charge.	COMPRISING.		Revenue Commissionership to which attached.
	Revenue District.	Rivers.	
1. Bashahr ...	The leased forest of Bashahr.	The River Sutlej from Rampur to Naila.	Delhi.
2. Umballa ...	Jullundur, Ludhiana, Umballa, and Simla.	The River Sutlej from Naila to the boundary of the Montgomery District.	Delhi & Jullundur.

The 25th May, 1892.—No. 253.—*Notification.*—Mr. G. G. Minniken, Deputy Conservator of Forests, on return from deputation in the Patiala State, assumed charge of the Bashahr Forest Division on the forenoon of the 5th May, 1892, relieving Mr. J. H. Lacey.

No. 256.—Notification.—Consequent on his services being placed at the disposal of the Government of India, Mr. A. E. Wild, Deputy Conservator of Forests, made over charge of the Hazara Forest Division to Mr. A. M. Reuther, Deputy Conservator of Forests, on the afternoon of the 16th April, 1892.

7.—CENTRAL PROVINCES GAZETTE.

25th May, 1892.—No. 3451.—Under Section 65 of Act VII of 1878 (the Indian Forest Act), the Chief Commissioner is pleased to invest Mr. Kashinath Kesho Thakur, M.A., Extra-Assistant Commissioner and Magistrate, 1st Class, in the Chanda District, with power to try summarily any forest offence punishable only with imprisonment for a term not exceeding six months, or fine not exceeding five hundred rupees, or both.

8.—BURMA GAZETTE.

25th April, 1892.—No. 145.—With reference to this department Notification No. 36, dated the 26th February, 1890, the Chief Commissioner appoints Mr. H. Moore-Lyons, Myoök, to succeed the Deputy Commissioner, Amherst district, as the Forest Settlement Officer who hold the enquiry ordered in that notification.

28th April, 1892.—No. 146.—With reference to this department Notification No. 112, dated the 28th March, 1892, Mr. T. H. Aplin, Deputy Conservator of Forests, received charge from Mr. J. W. Oliver, Conservator of Forests, of the Western Forest Circle, Upper Burma, on the 14th April, 1892, after noon.

23rd April, 1892.—No. 1.—With reference to Revenue Department Notification No. 264 (Forests), dated Rangoon, the 7th November, 1891, Lieutenant G. E. T. Green, Assistant Commissioner, assumed charge of his duties as Forest Settlement Officer for the proposed reserves notified in Revenue Department Notification No. 197 (Forests), dated the 13th November, 1890, on the afternoon of the 26th November, 1891.

5th May 1892.—No. 47.—Mr. R. F. Lewis, Extra Assistant Conservator, 4th grade, is promoted to be Extra-Assistant Conservator 3rd grade, substantive *pro tem.*, with effect from the date on which he assumed charge of his duties in the Ruby Mines district. On his transfer from the Ruby Mines district he will revert to his substantive rank.

29th April, 1892.—No. 1.—With reference to Revenue Department Notification No. 134, dated Rangoon, the 20th April, 1892, Mr. A. M. Burn-Murdoch, Assistant Conservator of Forests, made over, and Mr. C. W. A. Bruce, Assistant Conservator of Forests, received, charge of the Minbu Forest division, on the afternoon of the 22nd April, 1892.

27th April, 1892.—No. 1.—Mr. P. W. Healy, Extra Assistant Conservator of Forests, reported his arrival in Moulmein on the 18th instant and has been posted to the Attaran and Ye sub-division of the Salween-Atiaran division of which he assumed charge on the same date.

9th May, 1892.—No. 150.—Under the provisions of section 30 of the Forest Department Code, Mr. P. W. Healy is appointed to be an Extra Assistant Conservator of Forests, 4th grade, and is posted to the Tenasserim Forest circle.

10th May, 1892.—No. 151.—With reference to this department Notification No. 139, dated the 21st April 1892, imposing a duty on firewood in Upper Burma, the Chief Commissioner directs that the rule

published in that notification shall not come into force until the 1st August 1892.

12th May, 1892.—No. 152.—The following alterations of rank are ordered in the Forest Department :—

- (1) With effect from the 26th February 1891, and in supersession of so much of this department Notification No. 164, dated 4th August 1891, as related to Mr. Palmer :

Mr. C. W. Palmer, Deputy Conservator, 3rd grade, to be Deputy Conservator, 2nd grade,

- (2) With effect from the 15th June 1891 :

Mr. F. W. Thellusson, Deputy Conservator, 3rd grade, to be Deputy Conservator, 2nd grade.

- (3) Consequent on the re-organization of the Indian Forest Service, and with effect from the date on which Mr. Gradon assumed charge of his duties as Instructor at the Forest School, Dehra Dun :

Mr. A. F. Gradon to be an Assistant Conservator, 1st grade, and to officiate as Deputy Conservator, 4th grade.

- (4) With effect from the 2nd November 1891 :

Mr. H. Carter, Assistant Conservator, 1st grade, to officiate as Deputy Conservator, 4th grade.

Mr. E. A. O'Bryen, Assistant Conservator, 1st grade, to officiate as Deputy Conservator, 4th grade.

Mr. W. T. T. McHarg, Assistant Conservator, 2nd grade, to officiate as Assistant Conservator, 1st grade.

Mr. C. W. A. Bruce, Assistant Conservator, 2nd grade, to officiate as Assistant Conservator, 1st grade.

- (6) With effect from the 29th December, 1891, the date from which the transfer to Burma of Mr. Jellicoe, Deputy Conservator, took effect, and consequent on the re-organization of the Indian Forest Service :—

Mr. T. H. Aplin, Deputy Conservator, 2nd (officiating 1st) grade, to revert to his substantive rank.

Mr. F. J. Branthwaite, Assistant Conservator 1st (officiating Deputy Conservator 4th) grade, to revert to his substantive rank.

Mr. H. Carter, Assistant Conservator, 1st (officiating Deputy Conservator 4th) grade, to revert to his substantive rank.

4th May, 1892.—No. 524F.—Mr. T. H. Aplin, Deputy Conservator of Forests, Burma, is appointed to officiate as Conservator, 3rd grade, in charge of the Western Circle in Upper Burma, with effect from the 15th April, 1892 and until further orders.

The 14th May, 1892.—No. 155.—Mr. Maurice Kavanagh, who has been appointed on probation to be an Extra-Assistant Conservator of Forests in this province, reported his arrival in Rangoon on the 13th May, 1892, after noon.

Mr. Kavanagh is posted to the Chindwin Forest division, Western Circle, Upper Burma.

18th May, 1892.—No. 7.—With reference to Revenue Department Notification No. 118F. dated the 30th March last, Lieutenant E. C. Townsend, Assistant Commissioner, was employed on Forest Settlement duty in the Pegu circle from the 27th April, to 15th May, 1892.

9.—ASSAM GAZETTE.

9th May, 1892.—No. 3947G.—The following is published :

The undermentioned officer has been by Her Majesty's Secretary of State for India granted an extension of leave as advised in list dated the 24th March 1892 :

Name.	Service.	Appointment.	Period and nature of extension.
Mr. J. E. Barrett	...	Assistant Conservator of Forests.	Six months extraordinary leave without pay.

* This extension cancels the permission to return to duty granted to Mr. Barrett as advised in list dated the 12th ultimo.

20th May, 1892.—No. 4251G.—On the report of the Central Examination Committee, the Chief Commissioner directs the publication, for general information, of the results of the Half-yearly Examination of Deputy Commissioners, Assistant Commissioners, Extra Assistant Commissioners, and others, held on the 2nd, 3rd, 4th, and 5th May

Name.	Subjects taken up by Candidates.		Subjects in which passed.		Compulsory subjects in which still required to be passed.	
	Higher Standard.	Lower Standard.	Higher Standard.	Lower Standard.	Higher Standard.	Lower Standard.
Forest Officer.						
Mr. A. M. Long...	Forest Law ...	Land Revenue ...	Forest Law ...	Land Revenue
J. C. Kelley ...	Forest Law ...	Assamese ...	Forest Law ...	Assamese
Babu Nilkanta Mukerji. ...	Forest Law ...	Land Revenue ...	Forest Law ...	Land Revenue

10.—HYDERABAD RESIDENCY GAZETTE.

7th May, 1892.—No. 134.—Mr. G. F. Prevost, Deputy Conservator of Forests and District Forest Officer, Ellichpur, is granted six month's special leave on urgent private affairs, under article 348 of the Civil Service Regulations, with effect from the 15th June, 1892, or the subsequent date on which he may avail himself of the leave.

11.—MYSORE GAZETTE.—

4th May, 1892.—No. 48.—Mr. B. Hirasingh, Forest Probationer, is transferred to the charge of Shikarpur Forest Sub-Division. He assumed charge of his office on the forenoon of the 7th April, 1892.

Mr. Venkatnaranappa, Sub-Assistant Conservator of Forests, Shikarpur Sub-Division, is transferred to the Tumkur District; to join on the expiration of his leave.

12th May 1892.—C. Srinivasa Rao, Ranger, Bangalore District, is transferred to the Kolar District.

Mr. W. R. L. King, Ranger, Kolar District, is transferred to the Bangalore District to be posted to Closepet Range.

17th May, 1892.—No. 70.—Mr. H. Muttappa, Sub-Assistant Conservator of Forests, is granted privilege leave of absence for two weeks with effect from such date as he may avail himself of the same.

VIII.—EXTRACTS FROM OFFICIAL GAZETTES.

1.—GAZETTE OF INDIA.

20th May, 1892.—No 594F.—Consequent on the retirement from the service of the Lieutenant-Col. F. Bailey, R.E., Conservator of Forests, 1st grade, the following promotions are made among Conservators, with effect from 4th April 1892.

Mr. A. L. Home, Conservator, 2nd grade, to the 1st grade.

Mr. J. W. Oliver, Conservator, 3rd grade, and officiating in the 2nd grade, is confirmed in the latter grade.

Mr. R. H. E. Thompson, Deputy Conservator, 1st grade, and Officiating Conservator, 3rd grade, is confirmed in the latter appointment, and will officiate in the 2nd grade until further orders.

25th May, 1892.—No. 2105—F.—His Excellency the Viceroy and Governor-General is pleased to confer upon Hira Singh, Extra Assistant Conservator of Forests in Ajmere-Merwara, the title of Sardar as a personal distinction.

2.—MADRAS GAZETTE.

26th May, 1892.—No. 244.—Under section 2 of the Madras Forest (Act V. of 1882). His Excellency the Governor in Council is pleased to invest M. R. Ry. T Shama Rao, Deputy Tahsildar and Third-class Magistrate of Sathiavedu, Chingleput District, with powers to try forest offences.

26th May, 1892.—*Privilege Leave.*—To Mr. M. Callanan, Ranger, Third Grade, Cuddapah District, for two months, from 15th June 1892, under article 291 of the Civil Service Regulations.

Leave.—The Board of Revenue has granted eight days privilege leave under article 291 of the Civil Service Regulations, to M. R. Ry. Somasundaram Sastry Avargal, Forest Settlement Officer Nellore, Bellary and Anantapur Districts, from or after the 4th June 1892.

1st June 1892.—No. 243.—Mr. S. C. Moss, Extra Assistant Conservator, Second Grade, is appointed to act as District Forest Officer of Tinnevely during the absence of Mr. C. Du Pré Thornton on leave, or until further orders.

15th June 1892.—C. Venkataraman Iyer, Ranger on Rs. 50, is transferred from South to North Coimbatore.

20th June, 1892. In the "remarks" column of the Notification No. 221, dated 23rd May 1891, published at page 680 of Part I of the *Fort St. George Gazette*, dated 31st May 1892—

For the word "Do." against the name "Mr. C. D. McCarthy" read "with effect from 20th January 1892";

For the word "Do." against the name "Mr. C. DuPré Thornton" read "with effect from 21st January 1892"; and

For the word "Do." against the name "Mr. A. B. Jackson" read "to draw Rs. 250 till he passes the prescribed vernacular examination."

tric
e Dis
rred to
ib-Assistant
ice for two
he same.

8.—BOMBAY GAZETTE.

26th May, 1892.—Consequent on the return from privilege leave of Mr. G. S. Hinge, Extra Assistant Conservator of Forests, III Grade, Mr. E. G. Oliver, Deputy Conservator of Forests and Divisional Forest Officer, West Khandesh, delivered over and the former received charge of the Sub-Division Forest Office on the 13th instant, before noon.

28th May, 1892.—No. 4532.—His Excellency the Governor in Council is pleased to appoint—

Mr. Bhagvandas Harkisondas Dalal, L.C.E., to be substantive *pro tem.* Fourth Grade Extra Assistant Conservator of Forests in the Northern Circle; and

Mr. D. M. Bijur to be substantive *pro tem.* Fourth Grade Extra Assistant Conservator of Forests in the Southern Circle.

31st May, 1892.—Messrs. W. F. D. Fisher and L. S. Osmaston, Assistant Conservators of Forests, respectively delivered over and received charge of the South Sub-Division Forest Office, South Thana, on the 10th instant, after office hours

28th May, 1892.—Mr. B. G. Dashpande, Extra Assistant Conservator, who had been posted to Ratnagiri as per Government Resolution No. 4084, dated 11th May 1892, relinquished charge of his duties in Belgaum on the afternoon of 30th April 1892, received charge of the Ratnagiri Sub-Division from Mr. Wartak, Forest Ranger, on the 14th May 1892, after office hours, and then proceeded to Alibag and took charge of the Ratnagiri Divisional Office from Mr. Bell on the forenoon of 17th idem.

1st June, 1892.—Mr. Dattatraya Manjunath Bijur, who was appointed Extra Assistant Conservator in Government Resolution No. 4532, of the 28th May, 1892, reported himself for duty this day, during office hours.

7th June, 1892.—Mr. Chunilal Gulabchand Dalia, appointed to act as Extra Assistant Conservator of Forests, Fourth Grade, under Government Resolution No. 4226, dated 16th May 1892, in the Revenue Department, assumed charge of the duties of the Sub-Division Officer, Surat, on the forenoon of the 28th May 1892.

30th May, 1892.—Messrs. A. Lucas and H. F. Silcock respectively delivered over and received charge of the office of Forest Demarcation Officer, Dangs, and Assistant Political Agent, Khandesh, on 19th instant, in the afternoon.

9th June, 1892.—Mr. K. B. Phadke, Extra Assistant Conservator of Forests, Fourth Grade, delivered over charge of his duties in the Surat Division to the Divisional Forest Officer, Surat, on the 19th May 1892, after office hours, and received charge of the South Sub-Division Forest Office, South Thana, from the Divisional Forest Officer, South Thana, on 3rd June 1892, before office hours.

14th June, 1892.—Messrs. A. D. Wilkins and S. Hornidge, Deputy Conservators of Forests, respectively delivered over and received charge of the Divisional Forest Office, Ahmednagar, on the afternoon of the 9th instant.

Messrs. Joseph Baptista and V. D. P. Rebeiro, Extra-Assistant Conservators of Forests, respectively delivered over and received charge of the North Sub-Division Forest Office of the North Thana Division on the afternoon of the 1st June 1892.

Mr. J. H. Clabby, Extra Assistant Conservator of Forests, Fourth Grade, and Assistant Demarcation Officer, Thana, relinquished charge of his duties in the Thana District on the 3rd instant, in the afternoon, and took charge of the office of the Sub-Division Forest Officer, Poona, on the 4th idem, before office hours.

7th June, 1892.—Messrs. R. P. Ryan and G. A. Hight, Deputy Conservators of Forests, respectively delivered over and received charge of the Bijapur Forest Division on the afternoon of 30th ultimo.

Mr. T. R. D. Bell, Deputy Conservator, delivered over charge of the Divisional Forest Office, Kolaba, to Mr. N. K. Thanedar, Huzur Deputy Collector, on the afternoon of the 29th May 1892.

2. Mr. R. P. Ryan, Deputy Conservator, received the charge from Mr. Thanedar on the afternoon of the 1st instant.

4.—BENGAL GAZETTE.

27th May, 1892.—No. 2081.—In order to carry out the reorganization of the Indian Forest Service as finally sanctioned in the Circular No. 30F, dated the 29th December, 1891, issued by the Government of India, certain changes are required in the Upper Controlling Staff of the Forest Department in Bengal, as stated in the following paragraphs.

1. With effect from the 26th February, 1891, the date from which the Lieutenant-Governor is pleased to introduce the new scheme into Bengal—

Mr. E. G. Chester, Deputy Conservator, 3rd grade, to be Deputy Conservator, 2nd grade.

Mr. R. L. Heinig, Assistant Conservator, 1st grade, and Officiating Deputy Conservator, 4th grade, to be confirmed in the latter grade.

Mr. C. G. Rogers, Assistant Conservator, 1st grade, (on deputation to the Forest School, Dehra Dun), to officiate as Deputy Conservator, 4th grade, *vice* Mr. M. S. Fowler, Deputy Conservator, 4th grade—on leave.

Mr. H. D. D. French, Assistant Conservator, 1st grade, *sub. pro tem.*, to be Assistant Conservator, 1st grade, and to officiate as Deputy Conservator, 4th grade, *vice* Mr. Rogers (seconded).

Mr. H. H. Haines, Officiating Assistant Conservator, 1st grade, to be confirmed in that grade.

Mr. W. H. Lovegrove, Assistant Conservator, 2nd grade, to be Assistant Conservator, 1st grade, *sub. pro tem.*, *vice* Mr. Rogers (seconded).

2. With effect from the 21st March, 1891, the date on which Mr. M. S. Fowler, Deputy Conservator, 4th grade, returned from the leave granted to him in notification, dated the 16th December, 1890—

Mr. C. G. Rogers, Officiating Deputy Conservator, 4th grade, to revert to his substantive appointment of Assistant Conservator, 1st grade (seconded).

Mr. H. D. D. French, Officiating Deputy Conservator, 4th grade, to revert to his substantive appointment of Assistant Conservator, 1st grade.

3. With effect from the 4th May, 1891, the date on which Mr. H. H. Davis, Deputy Conservator, 1st grade, proceeded on furlough—

Mr. R. H. M. Ellis, Deputy Conservator, 2nd grade, and Officiating Deputy Conservator, 1st grade, to continue to officiate in the latter grade, *vice* Mr. Davis.

Mr. G. A. Richardson, Deputy Conservator, 3rd grade, to officiate as Deputy Conservator, 2nd grade, *vice* Mr. Ellis.

4. With effect from the 9th May, 1881, the date on which Mr. W. M. Green, Deputy Conservator, 3rd grade, proceeded on three months' privilege leave.

Mr. C. A. G. Lillingston, Deputy Conservator, 4th grade, to officiate as Deputy Conservator, 3rd grade.

Mr. C. G. Rogers, Assistant Conservator, 1st grade (seconded), to officiate as Deputy Conservator, 4th grade, *vice* Mr. Lillingston.

Mr. H. D. D. French, Assistant Conservator, 1st grade, to officiate as Deputy Conservator, 4th grade, *vice* Mr. Rogers (seconded).

5. With effect from the 2nd July, 1891, the date on which Mr. M. S. Fowler, Deputy Conservator, 4th grade, proceeded on nine months' medical leave out of India—

Mr. H. H. Haines, Assistant Conservator, 1st grade, to officiate as Deputy Conservator, 4th grade.

6. With effect from the 14th July, 1891, the date on which Mr. H. D. D. French, Officiating Deputy Conservator, 4th grade, proceeded on privilege leave—

Mr. W. H. Lovegrove, Assistant Conservator, 1st grade, *sub. pro tem.*, to officiate as Deputy Conservator, 4th grade.

7. With effect from the 31st July, 1891, the date on which Mr. M. S. Fowler, Deputy Conservator, 4th grade, died—

Mr. C. G. Rogers, Assistant Conservator, 1st grade, and Officiating Deputy Conservator, 4th grade (on deputation to the Forest School, Dehra Dun), to be confirmed in the latter grade (seconded).

Mr. H. D. D. French, Assistant Conservator, 1st grade, and Officiating Deputy Conservator, 4th, to be Deputy Conservator, 4th grade, *sub. pro tem.*, *vice* Mr. Rogers, (seconded).

Mr. W. H. Lovegrove, Assistant Conservator, 1st grade, *sub. pro tem.*, and officiating Deputy Conservator, 4th grade, to the Assistant Conservator 1st grade, and to continue to officiate as Deputy Conservator 4th grade.

8. With effect from the 9th August, 1891, the date on which Mr. W. M. Green, Deputy Conservator, 3rd grade, returned from privilege leave—

Mr. C. A. G. Lillingston, Officiating Deputy Conservator, 3rd grade, to revert to the substantive appointment of Deputy Conservator, 4th grade.

Mr. W. H. Lovegrove, Officiating Deputy Conservator, 4th grade, to revert to his substantive appointment of Assistant Conservator, 1st grade.

9. With effect from the 1st October, 1891—

Mr. G. A. Richardson, Officiating Deputy Conservator, 2nd grade, to revert to his substantive appointment of Deputy Conservator, 3rd grade.

Mr. F. B. Manson, Deputy Conservator, 3rd grade, to officiate as Deputy Conservator, 2nd grade, *vice* Mr. Ellis.

10. With effect from the 13th October, 1891, the date on which Mr. H. D. D. French, Deputy Conservator, 4th grade, *sub pro tem.*, returned from privilege leave—

Mr. H. H. Haines, Officiating Deputy Conservator, 4th grade, to revert to his substantive appointment of Assistant Conservator, 1st grade.

11. With effect from the 1st February, 1892, the date from which a post of Deputy Conservator, 3rd grade, was transferred to Bengal from Burma—

Mr. C. A. G. Lillingston, Deputy Conservator, 4th grade, to officiate as Deputy Conservator, 3rd grade.

Mr. H. H. Haines, Assistant Conservator, 1st grade, to officiate as Deputy Conservator 4th grade, *vice* Mr. Lillingston

12. The following Notifications in this Department are hereby cancelled:—

Notifications dated 21st April, 1891, and 28th October, 1891.

Notifications, Nos. 3929 For and 3930 For., dated the 29th December, 1891.

3rd June, 1892.—No. 2199.—It is hereby notified that Mr. F. B. Manson, Deputy Conservator of Forests, who, in notification, No. 3861 For., dated the 21st December, 1891, was posted to the charge of the Jalpaiguri Forest Division and entrusted with the special duty of preparing a Working Plan for the forests of that Division, ceased to be employed on the special work, with effect from the 1st May, 1892.

3rd June, 1892.—No. 2200.—Mr. C. C. Hatt, Assistant Conservator of Forests, attached to the Jalpaiguri Forest Division, is transferred to the Darjeeling Forest Division, with effect from the 25th May, 1892.

13th June, 1892.—No. 2273.—Mr. C. A. G. Lillingston, Officiating Deputy Conservator of Forests, third grade, Singhbhum Forest Division, is posted to the charge of the Chittagong Forest Division, *vice* Mr. R. H. M. Ellis, Officiating Deputy Conservator of Forests, first grade, transferred to Assam.

Mr. C. G. D. Fordyce, Deputy Conservator of Forests, third grade, who was transferred from Assam to Bengal by the Government of India's Notification, No. 612F., dated the 20th May, 1892, is posted to the charge of the Singhbhum Forest Division

14th June, 1892.—No. 2274F.—Mr. F. B. Manson, Deputy Conservator of Forests, in charge of the Jalpaiguri Forest Division, is granted three months' privilege leave, under article 291 of the Civil Service Regulations, with effect from the 25th June, 1892, or such subsequent date as he may avail himself of it.

Mr. W. M. Green, Deputy Conservator of Forests, on deputation as Personal Assistant to the Conservator of Forests, is posted to the charge of the Jalpaiguri Forest Division, during the absence, on leave, of Mr. Manson, or until further orders.

5.—N.-W. PROVINCES AND OUDH GAZETTE.

9th June 1892.—No 485F.—In supersession of Notifications No. 300, dated 28th February, 1880, No. 410F, dated 26th June, 1885, No. 807F, dated 19th October, 1889, and in accordance with the provisions of section 45 of the Indian Forest Act (VII of 1878), the Hon'ble the Lieutenant-Governor, North-Western Provinces, and Chief Commissioner of Oudh, is pleased to direct as follows:—

I.—The area within which all unmarked wood and timber shall be deemed to be the property of Government, until any person establishes his right and title thereto, shall be those specified below:—

- (a) All reserved and protected forests in the North-Western Provinces and Oudh.
- (b) The Jumna and its tributaries in British territory above the North-Western Railway Bridge at Rajghat, including an area within a direct distance of three miles from either bank of the main stream of the Jumna or of its tributary, the Tons, taking these streams at their cold season levels.
- (c) The Ganges and its tributaries in British territory above Garmukhtesar in the Meerut district, including an area within a direct distance of three miles from either bank of the main stream of the Ganges river, taking that stream at its cold season level.
- (d) The Rámanga and its tributaries in British territory above the road from Nagina to Afzalgarh, including an area within a direct distance of three miles from either bank of the main stream of the Rámanga river, taking that stream at its cold season level.
- (e) The Sarda, the Koriala, the Chanka, the Ghogra, and their tributaries in British territory above the road from Bahraighat to Bahraich, including an area within a direct distance of three miles from either bank of the main stream of the Sarda, Koriala, Chanka and Ghogra rivers, respectively, taking those streams at their cold season level.
- (f) The Rapti and its tributaries within British territory to junction of the Rapti with the Ghogra, including an area within a direct distance of three miles from either bank of the Rapti river, taking that stream at its cold season level.

II.—Within the areas specified in clauses (b) and (c) of Rule I, outside reserved and protected forests, the inhabitants of all villages bordering on the Ganges and Jumna or their tributaries, and all travellers shall be permitted to collect and take away for fuel, free of charge, headloads of timber of any of the kinds specified in section 45, Act VII of 1878, in pieces not exceeding six feet in length and two feet in length and two feet in girth.

III.—Outside the areas specified in clauses (a), (b) and (c) of Rule I, all wood and timber of the kinds referred to in section 45, Act VII of 1878, shall be exempt from the provisions of that section, excepting sal, sissu, deodar, tûn, asaina, haldu, chir and sundan timber in pieces exceeding two feet in girth and four feet in length.

17th June 1892.—No. 2836.—In Notification No. 462, dated 6th February, 1891, regarding the promotion of Messrs W. Shakespear, S. Eardley-Wilmot, F. B. Bryant, and L. Mercer, for "18th November" read "13th December."

22nd June 1892—No. 2938.—With effect from the 2nd July, 1891, the date on which Mr. A. Smythies, Deputy Conservator of Forests, 2nd grade, was appointed Deputy Director of the Forest School—

Mr. S. Eardley-Wilmot, Deputy Conservator, 3rd grade, to be Deputy Conservator, 2nd grade, continuing to officiate as Conservator of Forests, 3rd grade, under the Government of India;

Mr. F. B. Bryant, Officiating Deputy Conservator, 3rd grade, to be confirmed in that grade;

Mr. B. A. Rebsch, Officiating Deputy Conservator, 4th grade, to be confirmed in that grade.

No. 2939.—With effect from the 10th October, 1891, the date on which Mr. S. Eardley-Wilmot was appointed to be a Conservator of Forests, 3rd grade—

Mr. N. Hearle, Officiating Deputy Conservator, 2nd grade, to be confirmed in that grade.

No. 2940.—With effect from the 29th December 1891, the date on which his name was transferred to the North-Western Provinces 1st. Mr. E. A. Down to be Deputy Conservator, 3rd grade.

No. 2941.—With effect from the 6th March, 1892, *vice* Mr. A. Campbell, deceased—

Mr. L. Mercer, Officiating Deputy Conservator, 4th grade, to be confirmed in that grade;

Mr. A. P. Grenfell, Officiating Assistant Conservator, 1st grade, to be confirmed in that grade.

No. 2947.—The Notification from this Department, No. 3343, dated 28th July, 1891, regarding the temporary promotion of Mr. B. B. Osmaston, is hereby cancelled.

No. 2948.—With effect from the 1st July, 1891, the date on which M. L. Mercer, Officiating Deputy Conservator of Forests, 4th grade, proceeded on three months' privilege leave—

Mr. A. P. Grenfell, Officiating Assistant Conservator of Forests, 1st grade, to officiate as Deputy Conservator of Forests, 4th grade

No. 2949.—With effect from the 2nd July, 1891, the date on which Mr. A. Smythies was appointed Deputy Director of the Forest School—

Mr. F. B. Bryant, Deputy Conservator of Forests, 3rd grade, to officiate as Deputy Conservator of Forests, 2nd grade;

Mr. B. A. Rebsch, Deputy Conservator of Forests, 4th grade, to officiate as Deputy Conservator of Forests, 3rd grade;

Mr. B. B. Osmaston, Assistant Conservator of Forests, 1st grade, to officiate as Deputy Conservator of Forests, 4th grade.

No. 2950.—With effect from the 17th July, 1891, the date on which Mr. W. Shakespear, Officiating Conservator of Forests, reverted to his substantive appointment as Deputy Conservator of Forests 2nd grade—

Mr. F. B. Bryant, Officiating Deputy Conservator of Forests, 2nd grade, to revert to his substantive appointment as Deputy Conservator of Forests, 3rd grade;

Mr. B. A. Rebsch, Officiating Deputy Conservator of Forests, 3rd grade, to revert to his substantive appointment as Deputy Conservator of Forests, 4th grade;

Mr. A. P. Grenfell, Officiating Deputy Conservator of Forests, 4th grade, to officiate as Assistant Conservator of Forests, 1st grade.

No. 2951.—With effect from the 12th August, 1891, the date on which Mr. M. Hill, Officiating Deputy Conservator of Forests, 4th grade, proceeded on three months' privilege leave—

Mr. A. P. Grenfell, Officiating Assistant Conservator of Forests, 1st grade, to officiate as Deputy Conservator of Forests, 4th grade.

No. 2952.—With effect from the 1st October, 1891, the date on which Mr. L. Mercer, Officiating Deputy Conservator of Forests, 4th grade, returned from privilege leave—

Mr. A. P. Grenfell, Officiating Deputy Conservator of Forests, 4th grade, to officiate as Assistant Conservator of Forests, 1st grade.

No. 2953.—With effect from the 7th November, 1891, the date on which Mr. F. B. Bryant, Deputy Conservator of Forests, 3rd grade, proceeded on furlough—

Mr. B. A. Rebsch, Deputy Conservator of Forests, 4th grade, to officiate as Deputy Conservator of Forests, 3rd grade.

No. 2954.—With effect from the 29th December, 1891, the date on which Mr. A. F. Brown, Deputy Conservator of Forests, 3rd grade, was transferred to the Imperial list and Mr. E. A. Down was brought into the provincial list of the North-Western Provinces and Oudh—

Messrs. A. Campbell and B. A. Rebsch, Officiating Deputy Conservators of Forests, 3rd grade, to revert to their substantive appointments as Deputy Conservators of Forests, 4th grade ;

Messrs. M. Hill and B. B. Osmaston, Officiating Deputy Conservators of Forests, 4th grade, to revert to their substantive appointment, as Assistant Conservators of Forests, 1st grade.

No. 2955.—With effect from the 6th March, 1892, the date on which Mr. Mercer was confirmed as Deputy Conservator of Forests, 4th grade—

Mr. M. Hill, Assistant Conservator of Forests, 1st grade to officiate as Deputy Conservator of Forests, 4th grade.

No. 2956.—With effect from the 8th April, 1892, the date on which Mr. E. A. Down, Deputy Conservator of Forests, 3rd grades proceeded on furlough—

Mr. B. A. Rebsch, Deputy Conservator of Forests, 4th grade, to officiate as Deputy Conservator of Forests, 3rd grade ;

Mr. B. B. Osmaston, Assistant Conservator of Forests, 1st grade, to officiate as Deputy Conservator of Forests, 4th grade.

No. 2957.—With effect from the 18th April, 1892, the date on which Mr. L. Mercer, Deputy Conservator of Forests, 4th grade, proceeded on privilege leave—

Mr. A. P. Grenfell, Assistant Conservator of Forests, 1st grade, to officiate as Deputy Conservator of Forests, 4th grade.

No. 2958.—With effect from the 5th May, 1892, the date on which Mr. L. Mercer, Deputy Conservator of Forests, 4th grade, returned from privilege leave—

Mr. A. P. Grenfell, Officiating Deputy Conservator of Forests, 4th grade, to revert to his substantive appointment as Assistant Conservator of Forests, 1st grade.

6.—PUNJAB GAZETTE.

4th July, 1892.—No. 276.—In continuation of Punjab Government Notification No. 380, dated 30th October, 1891, and consequent on the return from deputation in the Patiala State of Mr. G. G. Minniken, Deputy Conservator of Forests, 3rd Grade, that officer will continue to officiate as Deputy Conservator of Forests, 2nd Grade, from the 21st of April, 1891.

No. 277.—Consequent on the departure of Mr. G. G. Minniken, Officiating Deputy Conservator of Forests, 2nd Grade, to Patiala State, the following promotions shall have effect from the 30th November, 1891 :—

- (1) Mr. F. O. Lemarchand, Officiating Deputy Conservator of Forests, 2nd Grade, to be Conservator of Forests, 2nd Grade, sub. *pro tem.* ;
- (2) Mr. E. A. Down, Deputy Conservator of Forests, 3rd Grade, sub. *pro tem.*, to be Officiating Deputy Conservator of Forests, 2nd Grade ;
- (3) Mr. A. M. Reuther, Officiating Deputy Conservator of Forests, 3rd Grade, to be Deputy Conservator of Forests, 3rd Grade, sub. *pro tem.* ;
- (4) Mr. J. H. Lace, Officiating Deputy Conservator of Forests, 3rd Grade, to be Deputy Conservator of Forests, 3rd Grade, sub. *pro tem.* ;
- (5) Mr. A. L. McIntire, Deputy Conservator of Forests, 4th Grade, sub. *pro tem.*, to be officiating Deputy Conservator of Forest 3rd Grade ;
- (6) Mr. R. J. P. Pinder, Officiating Deputy Conservator of Forests, 4th Grade, to be Deputy Conservator of Forests, 4th Grade, to be Deputy Conservator of Forests, 4th Grade, sub. *pro tem.* ;
- (7) Mr. E. R. Murray, Officiating Deputy Conservator of Forests, 4th Grade, to be Deputy Conservator of Forests, 4th Grade, sub. *pro tem.*

No. 278.—In continuation of Punjab Government Notification No. 243, dated 16th May, 1892, the following reversions shall have effect from the 14th of December, 1891, being the date of return of Mr. E. Forrest, Officiating Deputy Conservator of Forests, 2nd Grade, from furlough :—

- (1) Mr. F. O. Lemarchand, Deputy Conservator of Forests, 2nd Grade, sub. *pro tem.*, to be Officiating Deputy Conservator of Forests, 2nd Grade ;
- (2) Mr. E. A. Down, Officiating Deputy Conservator of Forests, 2nd Grade, to be Deputy Conservator of Forests, 3rd Grade, sub. *pro tem.* ;
- (3) Mr. A. L. McIntire, Officiating Deputy Conservator of Forests, 3rd Grade, to be Deputy Conservator of Forests, 4th Grade, sub. *pro tem.*

No. 279.—Consequent on the departure on privilege leave of Mr. E. A. Down, Deputy Conservator of Forests, 3rd Grade, sub. *pro tem.*, the following promotions shall have effect from the 4th December, 1891 :—

- (1) Mr. L. Gishborne Smith, Officiating Deputy Conservator of Forests, 3rd grade, to be Deputy Conservator of Forests, 3rd Grade, sub. *pro tem.* ;
- (2) Mr. A. L. McIntire, Deputy Conservator of Forests, 4th Grade, sub. *pro tem.*, to be Officiating Deputy Conservator of Forests, 3rd Grade.

7th June 1892.—No. 284.—The furlough granted to Mr. A. E. Wild, Forest Department, in *Punjab Government Gazette* Notification No. 48, dated 1st February 1892, is hereby cancelled.

7.—CENTRAL PROVINCES GAZETTE.

18th May, 1892.—No. 16.—Amrit Lal, Forester, 2nd grade, in the Hoshangabad Forest Division, having complied with the conditions laid down in Section 29 (1) (a) of the Forest Department Code, is promoted, under Section 47 of the said Code, to Ranger, 6th grade, or probation for one year, with effect from the 1st May, 1892.

9th June, 1892.—No. 1872.—Mr. A. M. F. Caccia, Assistant Conservator of Forests of the 3rd grade, is promoted to the 2nd grade of Assistant Conservators, with effect from the 26th February 1891.

Notification No. 6457, dated the 9th September, 1891, is hereby cancelled.

No. 1877.—Privilege leave for three months, under Article 291 of the Civil Service Regulations, is granted to Mr. H. B. Anthony, Deputy Conservator of Forests, Raipur, with effect from the 5th May, 1892, or the subsequent date or which he may be permitted to avail himself of it.

No. 1838.—Rule III of the rules made by the Chief Commissioner under Section 75 (d) of Act VII of 1878 (as amended by Act V of 1890) and published under Notification No. 3556, dated the 12th June 1890, is modified as follows, and published for general information :—

III. A monthly return (in the form of a copy made on loose sheets) of all such cases shall be submitted by each officer, through the Deputy Commissioner of the district, to the Conservator of the Circle, whom it should ordinarily reach by the 15th of the month succeeding that to which the return relates.

18th May 1892.—Whereas the Malguzar of Mauzah Ha'adgaon, in the Umarer Tahsil of the Nagpur District, has leased out his Forest to a contractor without the permission of the Deputy Commissioner; and whereas there is danger of the forest being destroyed, inasmuch as by the terms of his lease the lessee is authorized to cut and carry away every tree in the forest with a few exceptions, it is hereby declared, under Rule IV of the rules for the control and management of Malguzari forest lands, that the forest in Mauzah Haladgaon requires special protection.

11th June, 1892.—No. 1900.—The undermentioned officers of the Forest Department are declared to have passed the prescribed Departmental Examination in the subjects specified below :—

Mr. J. J. Hobday, B. A., Extra Assistant	} In Land Revenue and Forest Law.
Conservator	
Mr. W. G. Gilmore Forest Ranger ...	In Forest Law.

8.—BURMA GAZETTE

21th May, 1892.—No. 2.—With reference to Revenue Department Notification No 137F, dated Rangoon, the 21st April, 1892, Mr. E. A. O'Bryen, Assistant Conservator of Forests, received charge of the Katha division from Mr. E. S. Carr, Deputy Conservator of Forests, on the forenoon of the 16th May, 1892.

25th May 1892.—No. 162.—Mr. J. Messer Assistant Conservator of Forests, is transferred from Prome to Rangoon as personal Assistant to the Conservator of Forests. Pegu Circle.

25th May, 1892.—No. 165.—Mr. M. Laurie, i.c.s., Assistant Commissioner, is appointed as a temporary measure to be Settlement Officer in the Mandalay and Hyaukse districts.

25th May, 1892.—No. 2.—With reference to Revenue Department Notification No. 155, dated Rangoon, the 14th May 1892, Mr. Maurice Kavanagh, Extra Assistant Conservator of Forests, reported his arrival at Momywa, and assumed charge of the Revenue subdivision on the forenoon of the 20th May 1892.

30th May, 1892.—No. 169.—Under the provisions of section 34 of the Upper Burma Forest Regulation, 1887, the Chief Commissioner directs that the following rule shall be substituted for Rule 22 of the rules published in this Department Notification No. 59, dated the 11th April 1889.

22. (1) No taungya shall be cut in any area bearing teak trees except with the permission of the Deputy Commissioner or the Forest Officer in charge of the division or sub-division.
- (2) On and after the 1st December, 1892 no cutch trees measuring at their base 2 feet or more in girth standing on any land at the disposal of Government, shall be felled, lopped, girdled, or injured by fire or otherwise when clearing land for cultivation, except with the permission of the Deputy Commissioner or the Forest Officer in charge of the division or subdivision.
- (3) The local Government may exempt any defined tract from the operation of this rule and withdraw any such exemption.

No. 170.—Under section 34 of the Upper Burma Forest Regulation, VI of 1887, the Chief Commissioner directs that, with effect from the 1st June, 1892, the fee per cauldron for making catechu in Upper Burma shall be Rs 60 instead of Rs. 20 as heretofore.

For the words and figures *being at the rates of Rs 20 per cauldron* in Appendix II (catechu license) of the rules under the Upper Burma Forest Regulation, VI of 1887, shall be read the words and figures *being at the rate of Rs. 60 per cauldron*.

No. 171.—Under the provisions of section 6 of the Burma Forest Act, 1881, the Chief Commissioner appoints Mr. W. T. T. McHarg, Assistant Conservator of Forests, to be the Forest Officer, who shall assist the Forest Settlement Officer in the enquiry ordered in this department Notification No. 36, dated the 26th February, 1890.

31st May, 1892.—No. 172.—Mr. H. N. Thompson, Assistant Conservator of Forests, is transferred from Kindat to the charge of the Chindwin Forest division.

No. 173.—Under the provisions of Article 371 of the Civil Service Regulations Mr. J. Copeland, Deputy Conservator of Forests, is granted furlough to Europe for one year, with effect from the 8th June, 1892 or the subsequent date on which he may avail himself of it.

No. 174.—Mr. C. E. Muriel, Deputy Conservator of Forests, is transferred from Mōnywa to the charge of the Pyinman Forest division.

1st June 1892.—No. 8.—With reference to Revenue Department Notification No. 162F; dated the 25th May, 1892, Mr. Joseph Messer, Assistant Conservator of Forests, assumed charge of his duties as Personal Assistant to the Conservator of Forests, Pegu circle, on the forenoon of the 26th ultimo.

8th June 1892.—No. 180.—The following alterations of rank are ordered in the Forest Department :—

- (1) With effect from the 15th June, 1891, Mr. J. C. Murray, Deputy Conservator, 4th (officiating 3rd) grade, to be a Deputy Conservator, 3 grade.
- (2) With effect from the 1st February, 1892, consequent on the promotion of Mr. P. J. Carter to be a Conservator, on the temporary reduction of the 3rd grade of Deputy Conservators from six to five, and on the temporary increase of the 4th grade of Deputy Conservators from six to seven :
 - Mr. H. Slade, Deputy Conservator, 3rd grade, to be a Deputy Conservator, 2nd grade.
 - Mr. H. Hobart-Hampden, Deputy Conservator, 4th (officiating 3rd) grade, to revert to his substantive rank.
- (3) With effect from the 13th February 1892, consequent on the departure on furlough of J. Nisbet, Conservator :
 - Mr. T. H. Aplin, Deputy Conservator, 2nd grade, to officiate as Deputy Conservator, 1st grade.
 - Mr. H. B. Ward, Deputy Conservator, 3rd grade, to officiate as Deputy Conservator, 2nd grade.
 - Mr. H. Hobart-Hampden, Deputy Conservator, 4th grade, to officiate as Deputy Conservator, 3rd grade.
 - Mr. F. J. Branthwaite, Assistant Conservator, 1st grade, to officiate as Deputy Conservator, 4th grade.
- (4) With effect from the 4th March, 1892, consequent on the departure on privilege leave of Mr. H. A. Hoghton, Deputy Conservator :
 - Mr. C. E. Muriel, Deputy Conservator, 4th grade, to officiate as Deputy Conservator, 3rd grade.
 - Mr. H. Carter, Assistant Conservator, 1st grade, to officiate as Deputy Conservator, 4th grade.
- (5) With effect from the 15th April, 1892, consequent on the promotion of Mr. T. H. Aplin to officiate as a Conservator :
 - Mr. C. W. Palmer, Deputy Conservator, 2nd grade, to officiate as Deputy Conservator, 1st grade.
 - Mr. A. Weston, Deputy Conservator, 3rd grade, to officiate as Deputy Conservator, 2nd grade.
 - Mr. G. Q. Corbett, Deputy Conservator, 4th grade, to officiate as Deputy Conservator, 3rd grade.
 - Mr. E. A. O'Bryen, Assistant Conservator, 1st grade, to officiate as Deputy Conservator, 4th grade.

- (6) With effect from the 16th April, 1892, consequent on the departure on privilege leave of Mr. H. B. Ward, Deputy Conservator :
- Mr. J. C. Murray, Deputy Conservator, 3rd grade, to officiate as Deputy Conservator, 2nd grade.
 - Mr. H. Jackson, Deputy Conservator, 4th grade, to officiate as Deputy Conservator, 3rd grade.
 - Mr. W. F. L. Tottenham, Assistant Conservator, 1st grade, to officiate as Deputy Conservator, 4th grade.
- (7) With effect from the 16th May, 1892, consequent on the departure on furlough of Mr. E. S. Carr, Deputy Conservator :
- Mr. J. Copeland, Deputy Conservator, 4th (officiating 3rd, grade, to officiate as Deputy Conservator, 2nd grade.
 - Mr. H. Calthrop, Deputy Conservator, 4th grade, to officiate as Deputy Conservator, 3rd grade.
 - Mr. W. T. T. McHarg, Assistant Conservator, 2nd (officiating 1st) grade, to officiate as Deputy Conservator, 4th grade.

6th June, 1892.—No. 3.—With reference to Revenue Department Notification No. 127, dated Rangoon, the 31st May, 1892, Mr. C. E. Muriel, Deputy Conservator of Forests, made over and Mr. H. N. Thompson, Assistant Conservator of Forests received charge of, the Chindwin division on the afternoon of the 1st instant.

9th June, 1892.—No. 187.—Mr. T. J. Jellicoe was appointed to be a Deputy Conservator of Forests, 1st grade, in Burma, with effect from the 29th December, 1891.

11th June, 1892.—No. 3.—With reference to Revenue Department Notification No. 174 (Forests), dated Rangoon, the 31st May, 1892, Mr. J. Copeland, Deputy Conservator of Forests, made over, and Mr. C. E. Muriel, Deputy Conservator of Forests, received charge of, the Pynmana division on the afternoon of the 9th June, 1892.

15th June, 1892.—No. 189.—Mr. Cuthbert William Berry Anderson, who has been appointed on probation to be an Extra Assistant Conservator of Forests in this province, reported his arrival in Rangoon on the 15th June, 1892, before noon.

Mr. Anderson is posted to the Chindwin Forest division, West Circle, Upper Burma.

16th June, 1892.—No. 198.—Under the provisions of section 35 clause (a) of the Burma Forest Act, 1811, the Chief Commissioner declares, that with effect from the date of this notification, the under-mentioned tree standing on land at the disposal of Government shall be a reserved tree within the local limits specified :—

Kaunghmu, in the Mergui District of the Tenasserim division.

17th June, 1892.—No. 149.—At the departmental examinations held at Bassein, Moulmein, Bhamo, Mandalay, Minbu, Myingyan, and Yamethinin on the 6th and 7th June, 1892 the following officer passed the examination in Burmese by the standard specified below :—

Lower Standard.

Mr. W. A. Hearsey, Extra Assistant Conservator of Forests.

9.—ASSAM (GAZETTE).

20th June, 1892.—No 5214G.—Privilege leave of absence for three months, under article 291 of the Civil Service Regulations, is granted to Mr. D. P. Copeland, Deputy Conservator of Forests, Kamrup Forest Division, in charge of the Darrang Forest Division, with effect from the 20th July 1892, or the subsequent date on which he may avail himself of it.

20th June, 1892.—No. 5215G.—Mr. A. M. Long, Assistant Conservator, attached to the Kamrup Forest Division, is placed in charge of that division during the absence on privilege leave of Mr. D. P. Copeland, or until further orders, with effect from the date of receiving charge.

20th June, 1892.—No. 5216G.—Mr. J. C. Kelly, Extra Assistant Conservator, in charge of the Nowgong Forest Division, is placed in charge of the Darrang Forest Division, in addition to his own duties, until further orders, with effect from the date of receiving charge.

11.—MYSORE STATE GAZETTE.

25th May, 1892.—Mr. King, Ranger, is promoted from the 4th to the 3rd grade with effect from the 1st instant.

III.—EXTRACTS FROM OFFICIAL GAZETTES.

I.—GAZETTE OF INDIA.

1st July, 1892.—No. 840 -F.—The following transfers are made in the interests of the public service :

- (i) Mr. E. R. Murray, Deputy Conservator of Forests, 4th grade, sub *pro tempore*, Punjab, to the Madras Presidency as permanent Deputy Conservator, 4th grade.
- (ii) Mr. C. Somers-Smith, Assistant Conservator of Forests, 2nd grade, Madras Presidency, to the Punjab.

7th July, 1892.—No. 509.—With reference to Notification No. 189, dated the 22nd March last, Mr. C. G. Rogers Instructor at the Forest School, Dehra Dun, was on privilege leave from 30th March to 28th June 1892 (both dates inclusive.)

2.—MADRAS GAZETTE.

22nd June, 1892.—No. 284.—Mr. A. W. Lushington, Deputy Conservator of Forests, Madras, has been granted by the Right Honorable the Secretary of State for India an extension of three months leave on medical certificate, in continuation of the leave notified at page 1117, Part I of the *Fort St. George Gazette*, dated 1st December, 1891.

4th June, 1892.—*Promotions*.—The following promotions and transfers are made in the staff of Upper Subordinates of the Forest Department of the Northern Circle :—

Name.	Present grade.	Grade to which promoted.	Nature of promotion.	Remarks.
L. Hanumanthulu.	Forester, First Class.	Ranger, Fifth Class.	Acting.	With effect from 1st May 1892, <i>vice</i> Ranger M. Rathnasami Pillai, suspended.
K. Aswatham Naid.	Do. Second Class.	Do.	Do.	With effect from 1st May 1892, <i>vice</i> Ranger Balaji Singh, temporarily reduced to Forester.

Transfer.—

Name.	From district.	To district.	Remarks.
L. Hanumanthulu	... Bellary ...	Ganjam ...	

17th June, 1892.—P. R. Rath Nasami Pilley, Forest Ranger, Fifth Class, Godavari District, is reduced to Forester, First Class, with effect from 27th April 1892.

19th June, 1892.—L. Hanumanthulu, Acting Ranger, Fifth Class, is confirmed in the same appointment from 1st May 1892, *vice* Ruthnasami Pillai, reduced to Forester, First Class.

22nd July, 1892.—No. 326.—Mr. P. M. Lushington, District Forest Officer, Kurnool, privilege leave for three months, from or after 19th July, 1892, under article 291 of the Civil Service Regulation, 2nd Edition.

25th July, 1892, No. 327.—Mr. J. T. Lever, Deputy Collector, Fifth Class, to be Special Forest Settlement Officer for the Godavari, Kistna and Kurnool Districts.

3.—BOMBAY GAZETTE.

28th June, 1892.—Messrs. C. Fawcett and George Scott respectively delivered over and received charge of the Revenue, Magisterial and Forest Settlement work of the Mán, Khatáv and Khánápur Tálukas in the Sátára District on the 31st ultimo, in the afternoon.

4th July, 1892.—No. 2756.—Mr. R. P. Ryan, Deputy Conservator of Forests and Divisional Forest Officer, Kolaba, is allowed privilege leave of absence for one month and thirteen days from the 15th June, 1892.

4th July, 1892.—Messrs. F. H. Silcock and A. Lucas respectively delivered over and received charge of the office of the Forest Demarcation Officer, Dángs, and Assistant Political Agent, Khandesh, on 20th ultimo, in the forenoon.

4.—BENGAL GAZETTE.

9th July, 1892.—No. 2592.—In consequence of the change of the designation of *Sub-Assistant Conservators of Forests* to that of *Extra-Assistant Conservators of Forests*, prescribed in the Government of India, Revenue and Agricultural Department, Circular No. 18F, dated the 29th July, 1891, it is hereby notified that the latter title should be substituted for the title of Sub-Assistant Conservators, wherever it appears in the Notification of this Department, dated the 14th October, 1890, published at pages 997-98, Part I of the *Calcutta Gazette* of the 15th idem, conferring the powers of "Forest officers" therein specified on certain officers of the Forest Department.

18th July, 1892.—No. 2719.—Mr. Alfred Hailes Mee is appointed to officiate as an Extra-Assistant Conservator of Forests of the fourth grade on a pay of Rs. 100, with effect from the 1st April, 1892.

Mr. Mee is posted to the Sunderban Forest Division.

11th July, 1892.—No. 2719.—Mr. F. Trafford, Assistant Conservator of Forests, attached to the Singphum Forest Division, is granted three months' examination leave, under section 59J. of the Forest Department Code, with effect from the 1st July, 1892, or from such subsequent date as he may avail himself of it.

b.—N. W. PROVINCES AND OUDH GAZETTE.

29th June, 1892.—No. 3065.—Mr. B. B. Osmaston, Officiating Deputy Conservator of Forests, Central Circle, special leave for four months and nine days, with effect from the 17th June 1892, or subsequent date

29th June, 1892.—No. 3069.—Mr. J. M. Blanchfield, Extra Assistant Conservator of Forests, in charge of the Kumaun Forest Division, to hold charge of the Ganges Forest Division, in addition to his other duties, during the absence on leave of Mr. B. B. Osmaston, or until further orders.

30th June, 1892.—No. 572.—The Hon'ble the Lieutenant-Governor and Chief Commissioner is pleased to declare the undermentioned gentlemen to have passed the Departmental Examination of Junior Officers held on 18th April 1892 and following days in the subjects specified below :—

IV.—FOREST OFFICER.

Forest Law.

Mr. J. C. Tulloch, Assistant Conservator of Forests.

Vernacular.

By the Higher Standard.

Mr. J. C. Tulloch, Assistant Conservator of Forests.

V.—CANDIDATES FOR THE FOREST DEPARTMENT.

Vernacular.

Babu Baraja Gopal Nandi.

12th July, 1892.—No. 3293.—Mr. N. Hearle, Deputy Conservator of Forests, Dehra Dun Division, privilege leave for two months and twenty-eight days, with effect from 1st August 1892, or subsequent date.

15th July, 1892.—No. 3329.—The undermentioned officer has been granted by her Majesty's Secretary of State for India extension of leave :—

Name.	Service.	Appointment.	Period and nature of leave.
Mr. E. A. Down	Deputy Conservator of Forests.	Six months' on medical certificate.

6.—PUNJAB GAZETTE.

23rd July, 1892.—No. 342.—Consequent on his transfer to the Mooltan Forest Division, Babu Ladha Singh, Extra Assistant Conservator of Forests, was relieved of his duties in the Kangra Forests, Division on the forenoon of the 20th June 1892.

25th July, 1892.—No. 347.—Mr. A. V. Monro, Assistant Conservator of Forests, and Babu Ladha Singh, Extra Assistant Conservator of Forests, respectively made over and received charge of the Mooltan Forest Division on the afternoon of the 27th June 1892 consequent on the departure of the former on privilege leave for three months.

7.—CENTRAL PROVINCES GAZETTE.

30th June, 1892.—No. 4345.—The following officers of the Forest Department are declared to have passed the prescribed Departmental Examination in Forest Law :—

Mr. H. S. K. Edie, Assistant Conservator of Forests.

Mr. R. C. Thompson, Extra-Assistant Conservator of Forests.

12th July, 1892.—No. 4673.—Mr. R. C. Thompson, Extra-Assistant Conservator of Forests, is declared to have passed the prescribed Examination in Hindi by the Lower Standard.

8th July, 1892.—No. 2327.—Consequent on the appointment of Mr. A. F. Gradon, Officiating Deputy Conservator of Forests, 4th grade, as Instructor at the Forest School, Dehra Dun [*vide* Government of India, Revenue and Agricultural Department, Notification No. 916-F, dated the 10th August 1891], the following promotions are ordered, with effect from the 16th June 1891 :—

Name.	From	To
Mr. A. W. Blunt ...	Assistant Conservator of Forests, 1st grade, sub. <i>pro tem.</i>	Deputy Conservator of Forests, 4th grade.
Mr. M. Muttannah.	Officiating Assistant Conservator of Forests, 1st grade.	Assistant Conservator of Forests, 1st grade, sub. <i>pro tem.</i>

No. 2329.—Consequent on the return and transfer to the Central Provinces of Mr. L. A. W. Rind, Deputy Conservator of Forests, 3rd grade, the following reversions and promotions will have effect from the 26th June 1891 :—

Name.	From	To
Mr. G. F. Prevost ...	Officiating Deputy Conservator of Forests, 2nd grade (Berar.)	Deputy Conservator of Forests, 3rd grade (Berar.)
Mr. L. A. W. Rind...	Deputy Conservator of Forests, 3rd grade.	Officiating Deputy Conservator of Forests, 2nd grade.
Mr. H. B. Anthony.	Officiating Deputy Conservator of Forests, 3rd grade.	Deputy Conservator of Forests, 4th grade, sub. <i>pro tem.</i>
Mr. A. E. Lowrie ...	Deputy Conservator of Forests, 4th grade sub. <i>pro tem.</i>	Officiating Deputy Conservator of Forests, 4th grade.
Mr. A. W. Blunt ...	Officiating Deputy Conservator of Forests, 4th grade.	Assistant Conservator of Forests, 1st grade, sub. <i>pro tem.</i>
Mr. M. Muttannah...	Assistant Conservator of Forests, 1st grade sub. <i>pro tem.</i>	Officiating Assistant Conservator of Forests, 1st grade.

No. 2331.—Consequent on the appointment of Mr. J. McKee as Officiating Conservator of Forests, Assam [*vide* Government of India, Revenue and Agricultural Department, Notification No. 1024-F, dated the 10th September 1891], the following promotions are ordered, with effect from the 1st September, 1891 :—

Name.	From	To
Mr. G. F. Prevost ...	Deputy Conservator of Forests, 3rd grade, (Berar).	Officiating Deputy Conservator of Forests, 2nd grade (Berar.)
Mr. H. B. Anthony.	Deputy Conservator of Forests, 4th grade, sub. <i>pro tem.</i>	Officiating Deputy Conservator of Forests, 3rd grade.
Mr. A. E. Lowrie ...	Officiating Deputy Conservator of Forests, 4th grade.	Deputy Conservator of Forests, 4th grade, sub. <i>pro tem.</i>
Mr. A. W. Blunt ...	Assistant Conservator of Forests, 1st grade, sub. <i>pro tem.</i>	Officiating Deputy Conservator of Forests, 4th grade.
Mr. M. Muttannah.	Officiating Assistant Conservator of Forests, 1st grade.	Assistant Conservator of Forests, 1st grade, sub. <i>pro tem.</i>

21st July, 1892.—No. 2514.—Mr. A. A. Watson, Assistant Conservator of Forests, has been granted by Her Majesty's Secretary of State for India six months' leave on medical certificate, in extension of the fifteen months' leave on medical certificate granted him by Notification No. 917, dated the 22nd March, last.

.—BURMA GAZETTE.

20th June, 1892.—No. 199.—Under the provisions of clause (a) of section 35 of the Burma Forest Act, 1881, the Chief Commissioner declares that with effect from the 1st January 1893, pyinkado trees standing on any land at the disposal of Government shall be reserved trees within the local limits of the South Tehasserim Forest Division.

No. 200.—Under the provisions of section 37 of the Burma Forest Act, 1881, the Chief Commissioner directs that with effect from the 1st January, 1893—

(i) the following shall be substituted for the clause (1) (d) of Rule 8 of the rules under the Act :—

(d) such timber is cut, sawn, converted, or removed under and subject to the conditions of a license granted by the Deputy-Commissioner, or Forest Officer of the district, or by any officer empowered by the Deputy-Commissioner in that behalf, in one or other of the Forms Nos. VI, VIA, VII, VIIA, VIII, IXA, and IXB, given in the Appendix to these rules and ;

(ii) in the second line of License Forms VI and VII prescribed by this department Notification No. 14, dated the 21st January, 1892, the words " other than pyinkado " shall be inserted after the words " timber of the unreserved kinds."

21st June, 1892.—No. 4.—With reference to Revenue Department-Notification No. 196 dated Rangoon, the 18th June, 1892, Mr. H. N. Thompson, Assistant Conservator of Forests, Chindwin Division, made over, and Mr. H. H. Forteach, Assistant Conservator of Forests, received, charge of the Upper Chindwin subdivision on the forenoon of the 25th May, 1892.

23rd June, 1892.—No. 203.—Under the provisions of Article 291 of the Civil Service Regulations privilege leave for three months and 14 days is granted to Mr. C. W. Palmer, Deputy Conservator of Forests, with effect from the 8th July, 1892, or the subsequent date on which he may avail himself of it.

No. 204.—Mr. C. R. Dun, Assistant Conservator of Forests, is transferred from Maymyo to the charge of the Bhamo Forest Division.

28th June, 1892.—No. 206.—Mr. H. A. Hoghton, Deputy Conservator of Forests, is transferred from Toungoo to the headquarters of the Pegu Forest circle, Rangoon.

29th June, 1892.—No. 207.—Mr. W. T. T. McHarg, Assistant Conservator of Forests, is transferred from Moulmein to the charge of the Katha Forest Division.

No. 208.—Mr. P. W. Healy, Extra Assistant Conservator of Forests, is transferred from Moulmein to the charge of the Agency division and the Kado sub-division.

No. 209.—Under the provisions of Article 291 of the Civil Service Regulation privilege leave for three months and 15 days is granted to Mr. E. A. O'Bryen, Assistant Conservator of Forests, with effect from the 1st July, 1892, or the subsequent date on which he may avail himself of it.

No. 210.—Under the provisions of Article 291 of the Civil Service Regulations privilege leave for three months and 15 days is granted to Mr. C. H. Hobart-Hampden, Deputy Conservator of Forests, with effect from the 14th July 1892, or the subsequent date on which he may avail himself of it.

No. 211.—Mr. H. Carter, Assistant Conservator of Forests, in charge of the Working Plans division, Pegu Circle, is appointed to the charge of the Prome Forest Division in addition to his other duties during the absence of Mr. Hobart-Hampden on privilege leave, or until further orders.

30th June, 1892.—No. 212.—Under the provisions of Article 291 of the Civil Service Regulations privilege leave for one month is granted to Mr. J. Messer, Assistant Conservator of Forests, with effect from the 9th June 1892.

29th June, 1892.—No. 9.—Mr. H. A. Hoghton, Deputy-Conservator of Forests, reported his return from the privilege leave granted him in Revenue Department Notification No. 64F., dated the 26th February, 1892, on the afternoon of the 18th instant.

No. 10.—With reference to Revenue Department Notification No. 9, dated 28th June, 1892, Mr. H. A. Hoghton, Deputy Conservator of Forests, assumed charge of his duties at the headquarters of the Pegu circle on the forenoon of the 26th instant.

27th June, 1892.—No. 1.—Mr. W. T. T. McHarg, officiating Deputy-Conservator of Forests, made over, and Mr. P. W. Healy, Extra Assistant Conservator of Forests, received, charge of the Agency Division on the afternoon of the 24th June, 1892.

22nd June, 1892.—No. 5.—With reference to Revenue Department Notification No. 189, dated Rangoon, the 15th June, 1892, Mr Cuthbert William Berry Anderson reported his arrival at Mònywa on the afternoon of the 21st June, 1892.

13th July, 1892.—No. 11.—With reference to Revenue Department Notification No. 212 F, dated the 30th ultimo, Mr J. Messer, Assistant Conservator of Forests, availed himself of the privilege leave granted to him on the forenoon of the 9th idem.

No. 12.—With reference to the aforesaid Notification Mr. J Messer, Assistant Conservator of Forests, reported his return from privilege leave on the 9th July 1892, and assumed charge of his duties as Personal Assistant to the Conservator of Forests on the forenoon of the same day

12th July, 1892.—No. 4.—With reference to Revenue Department Notification No. 204 (Forests), dated the 23rd June, 1892, Mr. C. R. Dun, Assistant Conservator of Forests, relinquished charge of the Myitgnè sub-division on the afternoon of the 27th June, and assumed charge of the Bhambo Division from Mr. C. W. Palmer, Deputy Conservator of Forests, on the afternoon of the 7th July, 1892.

No. 5.—Mr. C. W. Palmer, Deputy Conservator of Forests, availed himself of the privilege leave granted him in Revenue Department Notification No. 203, dated the 23rd June, 1892, on the forenoon of the 8th July 1892.

No. 6.—With reference to Revenue Department Notification No. 207, dated the 29th June, 1892, Mr. W. T. T. McHarg, Assistant Conservator of Forests, assumed charge of the Katha Division from Mr. E. A. O'Bryen, officiating Deputy Conservator of Forests, on the afternoon of the 8th July, 1892.

No. 7.—Mr. E. A. O'Bryen officiating Deputy Conservator of Forests, availed himself of the privilege leave granted to him in Revenue Department Notification No. 209, dated the 29th June, 1892, on the forenoon of the 9th July, 1892.

16th July, 1892.—No. 182.—At the departmental examinations held at Moulmein, Bhamo, Minbu, and Yamèthin on the 6th and 7th June, 1892, the following Forest Officers passed the examination in Law and Revenue for Assistant Conservators of Forests:—

Mr. S. Carr, Assistant Conservator.

Mr. C. R. Dun, Assistant Conservator.

Mr. W. A. Hearsey, Extra Assistant Conservator.

Mr. P. W. Healy, Extra Assistant Conservator.

16th July, 1892.—No. 218.—In exercise of the power conferred by section 34 of the Upper Burma Forest Regulation, 1887, the Chief Commissioner extends the provisions of Rule 16 (c) of the Upper Burma Forest Rules to the Meiktila district.

19th July, 1892.—No. 219.—Under the provisions of section 70 of the Burma Forest Act, 1881, the Chief Commissioner invests Mr. P. W. Healy, Extra Assistant Conservator of Forests, in charge of the Kado Forest sub-division, with the following powers, that is to say:—

- (1). The powers of a Civil Court to compel the attendance of witnesses and the production of documents.
- (2). Power to issue search warrants under the Code of Criminal Procedure.
- (3). Power to hold enquiries into forest offences, and in the course of such enquiries to receive and record evidence.

11.—MYSORE GAZETTE.

23rd June, 1892.—No. 111.—Mr. Venkatnarnappa, Sub-Assistant Conservator of Forests, Tumkur District, who was granted privilege leave for two months in Notification No. 474. dated 13th, March 1892, having availed himself of only 48 days thereof, the unexpired portion, viz., 12 days, is hereby cancelled.

28th June, 1892.—First Grade Forest Ranger Monteiro is transferred from the Mysore District to the Kolar District to join on his return from the two months medical leave granted him.

Ranger Srinivas Rao, 4th Grade, who stands posted to the Kolar District, is transferred to the Mysore District for being posted to the Gundlupet Range *vice* Ranger Monteiro—To join forthwith.

8th July, 1892.—Ranger H. Ramaiya, 6th Grade, is promoted to 5th Grade with effect from the 1st instant.

III.—EXTRACTS FROM OFFICIAL GAZETTES.

1.—GAZETTE OF INDIA.

12th August, 1892.—No. 1037-F.—The following transfers are made in the interests of the public service :

Mr. H. A. Hoghton, Deputy Conservator of Forests, Burma, to the Central Provinces.

Mr. H. B. Anthony, Deputy Conservator, Central Provinces, to Burma.

2.—MADRAS GAZETTE.

25th July, 1892.—No. 331.—Mr. H. J. Porter, Deputy Conservator of Forest, Third Grade, to act as Deputy Conservator, Second Grade, from 21st October 1891 to 19th November, 1891.

No. 332.—Mr. C. E. Brasier, Deputy Conservator of Forests, Third Grade, to act as Deputy Conservator, Second Grade, from 20th November, 1891.

The above appointments are in lieu of Mr. Brasier's appointment as Acting Deputy Conservator of Forests, Second Grade, from 21st October, 1891.

22nd July, 1892.—Leave on medical certificate to Mr. W. H. Blacker, Ranger, sub. *pro tem.* North Arcot, for three months, under article 369 of the Civil Service Regulations, with effect from 14th July, 1892.

20th August, 1892.—No. 340.—Mr. T. N. Hearsey, Extra Assistant Conservator of Forests, Third Grade, to act as District Forest Officer, Kurnool, *vice* Mr. P. M. Lushington on leave, or until further orders.

4th August, 1892.—The following candidates have passed the Departmental Test held in July, 1892 :—

District.	Name.	Passed subject.	Marks.
Salem	M. Ahmed Hussain	Code and Accounts.	
South Arcot	K. Narayanaswami Aiyar	Do.	
	Mir Jaffir Ali Kirmani Sahib	Forest Law.	
	Srinivasachari	Do.	
North Arcot	M. Ramachandra Rao	Do.	
	Vasudeva Reddi	Do.	
	K. L. Munisami Aiyar	Code and Accounts and Forest Law.	
	S. Subramania Aiyar	Code and Accounts.	
	Rajagopal Mudaliar	Forest Law.	

5th August, 1892.—M. Subrayalu Naidu, Forester, First Grade, South Arcot, has passed the Departmental Test prescribed in para. 43 of the Code in surveying and Levelling.

8th August, 1892.—Probationary Ranger S. Eggia Narayana Shastri, Cuddapah, to revert to Forester, First Grade, with effect from 1st August, 1892.

8th August, 1892.—M. Subraiyalu Nayudu, Forester, First Grade, South Arcot, to officiate as Ranger, Fifth Grade, with effect from 1st August 1892.

10th August, 1892.—R. Sundrum Pillai, Ranger on Rs. 80, Nilgiri District, is granted privilege leave for two months, under article 291 of the Civil Service Regulations, from the date of his availing himself of the same.

27th July, 1892.—Mr. J. H. McLaughlin, Forest Ranger, Godavari District, is granted two months' privilege leave.

17th August, 1892.—No. 367.—Privilege leave for one month and sixteen days is granted to Mr. F. A. Lodge, District Forest Officer of Cuddapah, from 17th August, 1892, or from the date of his availing himself of the same.

19th August, 1892.—No. 368.—Mr. E. R. Murray, Deputy Conservator of Forests, Fourth Grade, is granted privilege leave for two months' with effect from the date of his relief in the Punjab by Mr. Somers Smith.

15th August, 1892.—No. 369.—T. Muhammad Ali Khan Sahib, Retired Assistant Conservator of Forests, Third Grade, will be considered to have been Assistant Conservator of Forests, First Grade, with effect from 21st October, 1891 to the date of his retirement.

17th August, 1892.—No. 370.—Mr. R. McIntosh, Assistant Conservator of Forests, Second Grade, to act as District Forest Officer, Cuddapah, during Mr. F. A. Lodge's absence on leave or until further orders.

19th August, 1892.—The Board of Revenue (Land Revenue) has granted one month's privilege leave, under article 291 of the Civil Service Regulations, to M. R. Ry. V. Alwar Chetty, District Forest Officer of Kistna.

19th August, 1892.—No. 376.—

Name.	Present Grade.	Grade to which promoted.	Nature of promotion.	Remarks.
Mr. W. C. Hayne	Deputy Conservator of Forests, Second Grade.	Deputy Conservator of Forests, First Grade.	Acting	With effect from 10th April, 1892
„ F. A. Lodge	Deputy Conservator of Forests, Third Grade.	Deputy Conservator of Forests, Second Grade.	Do.	Do.

16th August, 1892.—The following officers have passed the Departmental Examination held in July 1892, in Parts (a) and (b) of paragraph 56 of the Forest Code :—

		O. N. Kundaawami Pillai	Second Clerk, District Forest Office.	
Nilgiri District	...	S. Vyasa Row	Third Clerk.	do.
		C. S. Cheloova Iyer	Forester on Rs.	30.
		P. E. Barlow	" "	25.
		S. V. Ramanujam Chetty	" "	20.
South Coimbatore District.		C. S. Vennal Naidu	" "	20.
Madura District	...	S. Muthirilandi Pillai	" "	20.
		David Veda Manickam	Depôt Keeper.	
Tinnevely District	...	F. S. White	Forester on Rs.	40.
		T. S. Vanniswami Iyer	Forest Supervisor.	
North Malabar District		T. R. Ramaswami Iyer	Third Clerk, District Forest Office.	
South Canara District		B. D'Sa	Forester on Rs.	20.

18th August, 1892.—V. P. Ramalingam Pillai, Ranger on Rs. 125, on return from leave (1st September, 1892) is transferred from Nilgiris to Tinnevely.

T. Malaya Pillai, Ranger on Rs. 80, is transferred from Tinnevely to North Malabar.

N. M. Rego, Range on Rs. 80, is transferred from North Malabar to South Canara.

19th August, 1892.—G. Arulamandam Pillai, Forester on Rs. 40 and sub. *pro tem* Ranger on Rs. 50, Tinnevely District, is confirmed in the latter grade.

22nd August, 1892.—N. Arumuga Mudaliar, Ranger on Rs. 100, South Coimbatore, is granted furlough for five months, under Article 371 of the Civil Service Regulations, with effect from 20th September, 1892.

3.—BOMBAY GAZETTE.

27th July, 1892.—No. 6114.—The undermentioned officer passed as examination in Sindhi according to the Lower Standard on the 4th instant :—

Mr. L. H. Napier, Assistant Conservator of Forests, Sukkur.

27th July, 1892.—Messrs. L. S. Osmaston, Assistant Conservator of Forests, First Grade, and G. P. Millett, Deputy Conservator of Forests, Fourth Grade, respectively delivered over and received charge of the office of the Divisional Forest Officer, South Thana, on the 23rd July, 1892, before office hours.

1st August, 1892.—Mr. J. A. McIver, Forest Settlement Officer, Thana, is allowed privilege leave of absence for one month from 3rd instant under Article 291, Civil Service regulations.

9th August, 1892.—No. 3216.—Mr. L. S. Osmaston, Assistant Conservator of Forests, and Divisional Forest Officer, South Thana, is allowed furlough on medical certificate for six months under Article 343 of the Civil Service Regulations.

10th August, 1892.—No. 3222.—Mr. R. H. Madan, L. C.E., Extra Assistant Conservator of Forests and Divisional Forest Officer, Surat, is allowed privilege leave of absence for two months.

2nd August, 1892.—Messrs G. A. Hight and R. P. Ryan, Deputy Conservators of Forests, respectively delivered over and received charge of the Bijapur Divisional Forest Office on the forenoon of the 28th July, 1892.

12th August, 1892.—No. 6483.—His Excellency the Governor in Council is pleased to appoint Mr. G. P. Millett to hold charge of the office of the Divisional Forest Officer, South Thana, in addition to his own, during the absence of Mr. L. S. Osmaston or pending further orders.

12th August, 1892.—No. 6484.—His Excellency the Governor in Council is pleased to appoint Mr. W. A. Wallinger to act as Divisional Forest Officer, Surat, during the absence of Mr. R. H. Madan, L.C.E., on privilege leave, or pending further orders.

16th August, 1892.—No. 3296.—Mr. B. J. Haselden, Divisional Forest Officer, C. D., Kanara, is allowed furlough for one year.

No. 3302.—Mr. G. A. Hight, Divisional Forest Officer, Dharwar, is allowed furlough for one year from the 10th of September, 1892, or from such subsequent date as he may avail himself of it.

17th August, 1892.—No. 6613.—His Excellency the Governor in Council is pleased to appoint.—

Mr. W. R. Woodrow to act as Divisional Forest Officer, Dharwar, in addition to his own duties, with effect from the date of Mr. Hight's departure on leave; pending further orders.

Mr. T. R. D. Bell, on return from leave, to act as Divisional Forest Officer, C. D. of Kanara vice Mr. Haselden, pending further orders.

9th August, 1892.—Mr. W. R. Gaunde, Extra Assistant Conservator of Forests, First Grade, who was granted privilege leave for three months' under Government Resolution No. 17..., dated 20th April, 1892, Financial Department, reported himself for duty on the 5th instant, before office hours, to the Conservator of Forests, N. C., as directed by him, and was attached to his office.

12th August, 1892.—*Erratum*.—Please read "22nd" instead of "23rd" in the 5th line of the Conservator's notification dated 27th July, 1892, published on page 782 of the *Bombay Government Gazette* dated 4th August, 1892, Part I.

9th August, 1892.—Messrs F. R. Desai and E. G. Oliver, Deputy Conservators of Forests, respectively delivered over the received charge of the office of the Divisional Forest Officer, East Khandesh, on the 4th instant, in the afternoon.

4.—BENGAL GAZETTE.

9th August, 1892.—No. 2984.—Mr. C. C. Hatt, Assistant Conservator of Forests, attached to the Darjeeling Forest Division, is granted two months' examination leave, under section 59J of the Forest Department Code, with effect from the 1st August, 1892, or from any subsequent date on which he may avail himself of it.

August, 1892.—No. 3041.—Mr. C. A. G. Lillingston, Deputy Conservator of Forests, Chittagong Forest Division, is granted three months' privilege leave, under article 29, of the Civil Service Regulation, with effect from the 11th July, 1892.

Mr. C. G. D. Fordyce, Deputy Conservator of Forests, is posted, in supersession of the orders contained in this Department Notification, No. 2273For., dated the 13th June, 1892, to the charge of the Chittagong Forest Division, during the absence, on leave, of Mr. Lillingston, or until further orders.

Mr. E. J. N. James, Extra Assistant Conservator of Forests, is appointed to have charge of the Singbhum Forest Division until further orders.

18th August, 1892.—No. 3099.—The Lieutenant-Governor is pleased to direct that the following be substituted for this Department Notification, No. 2081For., dated the 27th May, 1892, published at page 591, Part I of the *Calcutta Gazette* of the 1st June, 1892, with reference to the changes rendered necessary by the re-organisation of the Indian Forest Service as finally sanctioned by the Government of India's Circular, No. 30F., dated the 29th December, 1891, and to the orders contained in their Circular No. 14F, dated the 31st May, 1892 :—

1. With effect from the 26th February, 1891, the date from which the Lieutenant-Governor is pleased to introduce the new scheme into Bengal—

Mr. E. G. Chester, Deputy Conservator, 3rd grade, to be Deputy Conservator, 2nd grade.

Mr. R. L. Heimig, Assistant Conservator, 1st grade, and Officiating Deputy Conservator, 4th grade, to be confirmed in the latter grade.

Mr. C. G. Rogers, Assistant Conservator, 1st grade (on deputation to the Forest School, Dehra Dun), to officiate as Deputy Conservator, 4th grade, *vice* Mr. M. S. Fowler, Deputy Conservator, 4th grade, on leave.

Mr. H. D. D. French, Assistant Conservator, 1st grade, *pro tem*, to be Assistant Conservator, 1st grade, and to officiate as Deputy Conservator, 4th grade, *vice* Mr Rogers (seconded).

Mr. H. H. Haines, Officiating Assistant Conservator, 1st grade, to be confirmed in that grade.

Mr. W. M. Lovegrove, Assistant Conservator, 2nd grade, to be Assistant Conservator, 1st grade, *vice* Mr. Rogers (seconded).

2 With effect from the 21st March, 1891, the date on which Mr. M. S. Fowler, Deputy Conservator, 4th grade, returned from the leave granted to him in notification dated the 16th December, 1890—

Mr. C. G. Rogers, Officiating Deputy Conservator, 4th grade, to revert to his substantive appointment of Assistant Conservator, 1st grade (seconded).

Mr. H. D. D. French, Officiating Deputy Conservator, 4th grade, to revert to his substantive appointment of Assistant Conservator, 1st grade.

3. With effect from the 4th May, 1891, the date on which Mr. H. H. Davis, Deputy Conservator, 1st grade, proceeded on furlough—

Mr. R. H. M. Ellis, Deputy Conservator, 2nd grade, and Officiating Deputy Conservator, 1st grade, to continue to officiate in the latter grade, *vice* Mr. Davis.

Mr. G. A. Richardson, Deputy Conservator, 3rd grade, to officiate as Deputy Conservator, 2nd grade, *vice* Mr. Ellis.

4. With effect from the 9th May, 1891, the date on which Mr. W. M. Green, Deputy Conservator, 3rd grade, proceeded on three months' privilege leave—

Mr. C. A. G. Lillingston, Deputy Conservator, 4th grade, to officiate as Deputy Conservator 3rd grade.

Mr. C. G. Rogers, Assistant Conservator, 1st grade (seconded), to officiate as Deputy Conservator, 4th grade, *vice* Mr. Lillingston.

Mr. H. D. D. French, Assistant Conservator, 1st grade, to officiate as Deputy Conservator, 4th grade, *vice* Mr. Rogers (seconded).

5. With effect from the 2nd July, 1891, the date on which Mr. M. S. Fowler, Deputy Conservator, 4th grade, proceeded on nine months' medical leave out of India.—

Mr. H. H. Haines, Assistant Conservator, 1st grade, to officiate as Deputy Conservator, 4th grade.

6. With effect from the 14th July, 1891, the date on which Mr. H. D. D. French, Officiating Deputy Conservator, 4th grade, proceeded on privilege leave.—

Mr. W. H. Lovegrove, Assistant Conservator, 1st grade, to officiate as Deputy Conservator, 4th grade.

7. With effect from the 31st July, 1891, the date on which Mr. M. S. Fowler, Deputy Conservator, 4th grade, died—

Mr. C. G. Rogers, Assistant Conservator, 1st grade, and Officiating Deputy Conservator, 4th grade (on deputation to the Forest School, Debra Dun), to be confirmed in the latter grade (seconded).

Mr. H. D. D. French, Assistant Conservator, 1st grade, and Officiating Deputy Conservator, 4th grade, to be Deputy Conservator 4th grade, *vice* Mr. Rogers (seconded).

8. With effect from the 9th August, 1891, the date on which Mr. W. M. Green, Deputy Conservator, 3rd grade, returned from privilege leave.—

Mr. C. A. G. Lillingston, Officiating Deputy Conservator, 3rd grade, to revert to his substantive appointment of Deputy Conservator, 4th grade.

Mr. W. H. Lovegrove, Officiating Deputy Conservator, 4th grade, to revert to his substantive appointment of Assistant Conservator, 1st grade.

9. With effect from the 1st October, 1891.—

Mr. G. A. Richardson, Officiating Deputy Conservator, 2nd grade, to revert to his substantive appointment of Deputy Conservator, 3rd grade.

Mr. F. B. Manson, Deputy Conservator, 3rd grade, to officiate as Deputy Conservator, 2nd grade, *vice* Mr. Ellis.

10. With effect from the 13th October, 1891, the date on which Mr. H. D. D. French, Deputy Conservator, 4th grade, returned from privilege leave.—

Mr. H. H. Haines, Officiating Deputy Conservator, 4th grade, to revert to his substantive appointment of Assistant Conservator, 1st grade.

11. With effect from the 1st February, 1892, the date from which a post of Deputy Conservator, 3rd grade, was transferred to Bengal from Burma.—

Mr. C. A. G. Lillingston, Deputy Conservator, 4th grade, to officiate as Deputy Conservator, 3rd grade.

Mr. H. H. Haines, Assistant Conservator, 1st grade, to officiate as Deputy Conservator, 4th grade, *vice* Mr. Lillingston.

12. The following Notifications in this Department are hereby cancelled.—

Notifications, dated 21st April, 1891 and 28th October, 1891.

Notification, Nos. 3929F- and 3940F., dated 29th December, 1891.

19th August, 1892.—No. 3118.—Consequent on the transfer of Mr. R. H. M. Ellis, Officiating Deputy Conservator, first grade, Bengal, to Assam, and of Mr. C. G. D. Fordyce, Deputy Conservator, third grade, Assam, to Bengal, the following promotions are made in the Upper Controlling Staff of the Bengal Forest Department, with effect from the 16th May, 1892 :—

Mr. F. B. Manson, Officiating Deputy Conservator, second grade, is confirmed in that grade, *vice* Mr. R. H. M. Ellis, transferred to Assam.

Mr. E. G. Chester, Deputy Conservator, second grade, is appointed to officiate in the first grade of Deputy Conservators, *vice* Mr. H. H. Davis, on furlough, *vice* Mr. R. H. M. Ellis, transferred.

Mr. C. G. D. Fordyce, Deputy Conservator, third grade, is appointed to officiate in the second grade of Deputy Conservators, *vice* Mr. E. G. Chester.

19th August, 1892.—No. 3119.—Consequent on the grant of three months' privilege leave to Mr. F. B. Manson, Deputy Conservator of Forests, second grade, the following temporary promotions are made in the Upper Controlling Staff of the Bengal Forest Department, with effect from the 27th June, 1892 :—

Mr. G. A. Richardson, Deputy Conservator of Forests, third grade, is appointed to officiate in the second grade of Deputy Conservators, *vice* Mr. F. B. Manson.

Mr. R. L. Heinig, Deputy Conservator of Forests, fourth grade, is appointed to officiate in the third grade of Deputy Conservators, *vice* Mr. G. A. Richardson.

Mr. W. H. Lovegrove, Assistant Conservator of Forests, first grade, is appointed to officiate in the fourth grade of Deputy Conservators, *vice* Mr. R. L. Heinig.

5.—N.-W. P AND. OUDH GAZETTE.

4th August, 1892.—No. 686F—Whereas, by Government of India, Revenue and Agricultural Department (Forests), Circular No. 18F, dated 29th July, 1891, the designation of Sub-Assistant Conservator of

1. Nos. 301 and 302, dated 28th February, 1880.

2. No. 1004, dated 2nd November, 1880.

3. No. 489F dated 26th June, 1889.

4. No. 48F dated 27th January, 1890.

Department Notifications detailed on the margin.

17th August, 1892.—No. 3818 Mr. A. P. Grenfell, Assistant Conservator of Forests, 1st grade, to hold charge of the Dehra Dun

Division, in addition to the charge of the Sabaraupur Division, with effect from the 1st August, 1892, during the absence on privilege leave of Mr. N. Hearle, Deputy Conservator of Forests, 2nd grade, or until further orders.

6.—PUNJAB GAZETTE.

2nd August, 1892.—No. 358 S.—*Notification*.—With reference to the Notification by the Government of India in the Revenue and Agricultural Department, No. 840F, dated 1st July, 1892, the services of Mr. E. R. Murray, Deputy Conservator of Forests, are placed at the disposal of the Government of Madras with effect from such date as he may be relieved of his duties in the Punjab.

8th August, 1892.—No. 364.—*Notification*.—In Punjab Government Notification No. 532F., and 533F., dated the 8th December, 1879, investing Forest Officers with certain powers under the Forest Act, 1878, the designation "*Extra Assistant Conservator*" should be substituted for "*Sub-Assistant Conservator*," wherever it occurs.

20th August, 1892.—No. 379.—In consequence of the amalgamation of the Controlling Staff of the Forest Department of the Punjab with those of the Central Provinces, Berar and Coorg, in accordance with Government of India Circular No. 30F., dated the 29th December, 1891, the following list is published showing the names and position of the officers on the combined lists on the 29th December 1891:—

Serial No. in list.	Name.	Position.	
1	Mr. R. H. E. Thompson	Deputy Conservator of Forests, 1st Grade.	Officiating Conservator.
2	„ J. C. McDonell ...	Ditto ...	Seconded, on deputation.
3	„ A. E. Wild ...	Ditto ...	Officiating Conservator.
4	„ F. B. Dickinson ...	Ditto ...	Ditto ditto.
5	„ C. F. Elliot ...	Ditto ...	Substantive (provisional).
6	„ J. McKee ..	Deputy Conservator of Forests, 2nd Grade.	Officiating Conservator.
7	„ G. G. Minniken ...	Ditto ...	Seconded, on deputation.
8	„ W. P. Thomas ...	Ditto ..	Officiating Deputy Conservator of Forests, 1st Grade.
9	„ G. H. Foster ...	Ditto ...	Ditto ditto.
10	„ E. Forrest ...	Ditto ...	Substantive (provisional) and Officiating Deputy Conservator of Forests, 1st Grade.

Serial No. in list.	Name.	Position.	
11	Mr. L. A. W. Rind ...	Ditto ...	Substantive (provisional).
12	„ F. O. Lemarchand...	Deputy Conservator of Forests, 3rd Grade.	Officiating Deputy Conservator of Forests, 2nd Grade.
13	„ G. F. Prevost ...	Ditto ...	Ditto ditto.
14	„ A. J. Mein ...	Ditto ...	On furlough.
15	„ J. Ballantine ...	Supernumerary Deputy Conservator of Forests, 3rd Grade.	Sub. <i>pro tem.</i> , second-ed.
16	„ E. Dobbs ...	Ditto ...	Substantive (provisional), Officiating Deputy Conservator of Forests, 2nd Grade.
17	„ W. King ...	Deputy Conservator of Forests, 4th Grade.	On furlough.
18	„ J. H. Lace ...	Deputy Conservator of Forests, 3rd Grade.	Substantive (provisional), Officiating Deputy Conservator of Forests, 2nd Grade.
19	„ L. G. Smith ...	Deputy Conservator of Forests, 4th Grade.	Officiating Deputy Conservator of Forests, 3rd Grade.
20	„ J. L. Pigot ..	Ditto ...	Seconded, on deputation.
21	„ F. S. Barker ...	Ditto ...	Officiating Deputy Conservator of Forests, 3rd Grade.
22	„ H. Moore ...	Ditto ...	Ditto ditto.
23	„ G. F. Taylor ...	Supernumerary Deputy Conservator of Forests, 4th Grade.	Substantive (provisional), Officiating Deputy Conservator of Forests, 3rd Grade.
24	„ A. L. McIntire ...	Deputy Conservator of Forests, 4th Grade.	Ditto ditto.
25	„ H. B. Anthony ...	Ditto ...	Substantive (provisional).
26	„ F. C. Hicks ...	Ditto ...	Ditto ditto.
27	„ R. J. P. Pinder ...	Assistant Conservator of Forests, 1st Grade.	Officiating Deputy Conservator of Forests, 4th Grade.
28	„ A. E. Lowrie ...	Ditto ...	Ditto ditto.
29	„ A. A. Watson ...	Ditto ...	On furlough.
30	„ E. R. Murray ...	Ditto ...	Officiating Deputy Conservator of Forests, 4th Grade.
31	„ G. S. Hart ...	Assistant Conservator of Forests, 2nd Grade.	On leave.

Serial No. in list.	Name.	Position.	
32	Mr. C. P. Fisher ...	Assistant Conservator of Forests, 1st grade.	Substantive (provisional). Officiating Deputy Conservator of Forests, 4th Grade.
33	„ A. V. Monro ...	Ditto ...	Ditto ditto.
34	„ A. W. Blunt ...	Ditto ...	Ditto ditto.
35	„ M. Muttannah ...	Ditto ...	Substantive (provisional).
36	„ P. H. Clutterbuck ...	Assistant Conservator of Forests, 2nd Grade.	Officiating Assistant Conservator of Forests, 1st Grade.
37	„ A. M. F. Caccia ...	Ditto ...	Ditto ditto.
38	„ E. M. Coventry ..	Ditto ...	Ditto ditto.
Super-numerary.	„ V. S. Menzies ..	Ditto ...	Ditto ditto.

20th August 1892.—No. 380.—Consequent on the appointment to the Central Provinces of Mr. H. S. K. Edie, *vide* Government of India Notification No. 532F., dated the 6th May 1892, the amalgamated list of the Punjab, Central Provinces, Berar and Coorg will, on the 31st December 1891, stand as follows :—

Serial No. in list.	Name.	Position.	
1.—38 Super-numerary.	} Same names as in notification	...	{ No. 379, dated 20th August 1892.
Do.		H. S. K. Edie...	Ditto

20th August 1892.—No. 381.—Consequent on the transfer to the Imperial List of Mr. A. E. Wild on his appointment as Conservator of Forests, 3rd Grade, *vide* Government of India Notification No. 5266-F., dated the 6th May 1892, the following promotions shall have effect from the 17th January 1892 :—

Mr. C. F. Elliott, Deputy Conservator of Forests, 1st Grade, substantive (provisional), to be Deputy Conservator of Forests, 1st Grade.

Mr. W. P. Thomas, Officiating Deputy Conservator of Forests, 1st Grade, to be Deputy Conservator of Forests, 1st Grade, substantive (provisional).

Mr. E. Forrest, Deputy Conservator of Forests, 2nd Grade, substantive (provisional), and Officiating Deputy Conservator of Forests 1st Grade, to be Deputy Conservator of Forests, 2nd Grade, and to continue to officiate in the 1st Grade.

Mr. F. O. Lemarchand, Officiating Deputy Conservator of Forests, 2nd Grade, to be Deputy Conservator of Forests, 2nd Grade, substantive (provisional).

Mr. J. Ballantine, Supernumerary Deputy Conservator of Forests, 3rd Grade, sub. *pro tem.*, on deputation, to be Deputy Conservator of Forests, 3rd Grade.

Mr. L. G. Smith, Officiating Deputy Conservator of Forests, 3rd Grade, to be Deputy Conservator of Forests, 3rd Grade, substantive (provisional).

Mr. G. F. Taylor, Supernumerary Deputy Conservator of Forests, 4th Grade, substantive (provisional), and Officiating Deputy Conservator of Forests, 3rd Grade, to be Deputy Conservator of Forests, 4th Grade, and to continue to officiate in the 3rd Grade.

Mr. R. J. P. Pinder, Officiating Deputy Conservator of Forests, 4th Grade, to be Deputy Conservator of Forests, 4th Grade, substantive (provisional).

Mr. G. S. Hart, Assistant Conservator of Forests, 2nd Grade, on leave, to be Assistant Conservator of Forests, 1st Grade.

20th August.—No. 382.—Consequent on the departure of Mr. F. S. Barker, Officiating Deputy Conservator of Forests, 3rd Grade, on leave on medical certificate for 12 months, the following promotions shall have effect from the 22nd January 1892 :—

Mr. H. B. Anthony, Deputy Conservator of Forests, 4th Grade, substantive (provisional, to officiate as Deputy Conservator of Forests, 3rd Grade.

Mr. M. Muttanah, Assistant Conservator of Forests, 1st Grade, substantive (provisional), to officiate as Deputy Conservator of Forests, 4th Grade.

20th August 1892.—No. 383.—Consequent on the return from furlough of Mr. W. King, Deputy Conservator of Forests, 4th Grade, the following changes shall have effect from the 8th February 1892 :—

Mr. W. King, Deputy Conservator of Forests, 4th Grade, to be Deputy Conservator of Forests, 3rd Grade, substantive (provisional) and Officiating Deputy Conservator of Forests, 2nd Grade.

Mr. J. H. Lace, Officiating Deputy Conservator of Forests, 2nd Grade, to revert to Deputy Conservator of Forests, 3rd Grade, substantive (provisional).

Mr. L. G. Smith, Deputy Conservator of Forests, 3rd Grade, substantive (provisional), to be Deputy Conservator of Forests, 4th Grade, and Officiating Deputy Conservator of Forests, 3rd Grade.

Mr. H. B. Anthony, Officiating Deputy Conservator of Forests, 3rd Grade, to revert to Deputy Conservator of Forests, 4th Grade, substantive (provisional).

Mr. M. Muttannah, Officiating Deputy Conservator of Forests, 4th Grade, to revert to Assistant Conservator of Forests, 1st Grade, substantive (provisional).

20th August 1892.—No. 364.—Consequent on the return from leave of Mr. G. S. Hart, Assistant Conservator of Forests, 1st Grade, the following changes shall have effect from the 13th February 1891 :—

Mr. G. S. Hart, Assistant Conservator of Forests, 1st Grade, to be Officiating Deputy Conservator of Forests, 4th Grade.

Mr. C. W. Blunt, Officiating Deputy Conservator of Forests, 4th Grade, to revert to Assistant Conservator of Forests, 1st Grade, substantive (provisional).

20th August 1892.—No. 385.—Consequent upon the death of Mr. C. J. Mein, Deputy Conservator of Forests, 3rd Grade, the re-transfer from Assam to the Punjab of Mr. A. M. Reuther, Deputy Conservator of Forests, 4th Grade, and the transfer of Mr. J. L. Pigot, Deputy Conservator of Forests, 4th Grade, from the Central Provinces to Assam, the following changes shall have effect from the 2nd of March 1892 :—

Mr. E. Dobbs, Deputy Conservator of Forests, 3rd Grade, substantive (provisional), and Officiating Deputy Conservator of Forests, 2nd Grade, to be Deputy Conservator of Forests, 3rd Grade, and to continue to officiate in the 2nd Grade.

Mr. C. M. Reuther, Deputy Conservator of Forests, 4th Grade, to be Deputy Conservator of Forests, 3rd Grade, substantive (provisional).

Mr. C. L. McIntire, Deputy Conservator of Forests, 4th Grade, substantive (provisional), and Officiating Deputy Conservator of Forests, 3rd Grade, to be Deputy Conservator of Forests, 4th Grade.

Mr. C. P. Fisher, Assistant Conservator of Forests, 1st Grade, substantive (provisional), and Officiating Deputy Conservator of Forests, 4th Grade, to be Assistant Conservator of Forests, 1st Grade, and to continue to officiate as Deputy Conservator of Forests, 4th Grade.

Mr. A. V. Monro, Officiating Deputy Conservator of Forests, 4th Grade, to revert to Assistant Conservator of Forests, 1st Grade, substantive (provisional).

20th August 1892.—No. 386.—Consequent on the appointment of Mr. R. H. E. Thompson, Deputy Conservator of Forests, 1st Grade, as Conservator of Forests, 3rd Grade, *vide* Government of India Notification No. 594-F., dated the 20th May 1892, the following promotions shall have effect from the 4th April 1892 :—

Mr. J. McKee, Deputy Conservator of Forests, 2nd Grade, and Officiating Conservator of Forests to be Deputy Conservator of Forests, 1st Grade, and to continue to officiate as Conservator of Forests.

Mr. L. A. W. Rind, Deputy Conservator of Forests, 2nd Grade, substantive (provisional), to be Deputy Conservator of Forests, 2nd Grade.

Mr. G. F. Prevost, Officiating Deputy Conservator of Forests, 2nd Grade, to be Deputy Conservator of Forests, 2nd Grade, substantive (provisional).

Mr. W. King, Deputy Conservator of Forests, 3rd Grade, substantive (provisional), and Officiating Deputy Conservator of Forests,

2nd Grade, to be Deputy Conservator of Forests, 3rd Grade, and to continue to officiate in the 2nd Grade.

Mr. L. G. Smith, Officiating Deputy Conservator of Forests, 3rd Grade, to be Deputy Conservator of Forests, 3rd Grade, substantive (provisional).

Mr. H. B. Anthony, Deputy Conservator of Forests, 4th Grade, substantive (provisional), to be Deputy Conservator of Forests, 4th grade.

Mr. C. E. Lowrie, Officiating Deputy Conservator of Forests, 4th Grade, substantive (provisional).

Mr. C. V. Monro, Assistant Conservator of Forests, 1st Grade, substantive (provisional) to be Assistant Conservator of Forests, 1st Grade.

Mr. P. H. Clutterbuck, Officiating Assistant Conservator of Forests, 1st Grade, to be Assistant Conservator of Forests, 1st Grade, substantive (provisional).

No. 387.—Consequent on the return from deputation in the Patiala State of Mr. G. G. Minniken, Deputy Conservator of Forests, 2nd Grade, the following changes shall have effect from the 5th May, 1892:—

Mr. G. G. Minniken, Deputy Conservator of Forests, 2nd Grade to be Deputy Conservator of Forests, 1st Grade, substantive (provisional).

Mr. W. P. Thomas, Deputy Conservator of Forests, 1st Grade, substantive (provisional) to be Deputy Conservator of Forests, 2nd Grade, and to officiate in the 1st Grade.

Mr. E. Forrest, Officiating Deputy Conservator of Forests 1st Grade, to revert to Deputy Conservator of Forests, 2nd Grade.

Mr. G. F. Prevost, Assistant Conservator of Forests, 2nd Grade, substantive (provisional), to be Deputy Conservator of Forests, 3rd Grade, and to officiate in the 2nd Grade.

Mr. W. King, Officiating Deputy Conservator of Forests, 2nd Grade, to revert, to Deputy Conservator of Forests, 3rd Grade.

Mr. L. G. Smith, Deputy Conservator of Forests, 3rd Grade, substantive (provisional), to be Deputy Conservator of Forests, 4th Grade, and to officiate in the 3rd Grade.

Mr. G. F. Taylor, Officiating Deputy Conservator of Forests, 3rd Grade, to revert to Deputy Conservator of Forests, 4th Grade.

Mr. C. E. Lowrie, Deputy Conservator of Forests, 4th Grade, substantive (provisional), to be Assistant Conservator of Forests, 1st Grade, and to officiate as Deputy Conservator of Forests, 4th Grade.

Mr. C. P. Fisher, Officiating Deputy Conservator of Forests, 4th Grade to revert to Assistant Conservator of Forests, 1st Grade.

Mr. P. H. Clutterbuck, Assistant Conservator of Forests, 1st Grade, substantive (provisional) to be Assistant Conservator of Forests, 2nd Grade, and to officiate in the 1st Grade.

No. 388.—Consequent on the departure on three months' privilege leave of Mr. H. B. Anthony, Deputy Conservator of Forests, 4th Grade, the following promotion shall have effect from the 8th of June 1892:—

Mr. C. P. Fisher, Assistant Conservator of Forests, 1st Grade, to be Officiating Deputy Conservator of Forests, 4th Grade.

26th August, 1892.—No. 395.—Consequent on his transfer from Madras to the Punjab, Mr. C. Somers Smith, Assistant Conservator of Forests, 2nd Grade, reported his arrival at Lahore on the forenoon of the 21st July, 1892, from which date he has been attached to the Direction Division.

7.—CENTRAL PROVINCES GAZETTE.

26th July, 1892.—No. 2617.—Mr. Ramchandra, Extra-Assistant Conservator of Forests, in charge of the Moharli Sub-Division, Chanda, is transferred to the Balaghat Forest Division.

No. 2618.—Khan Saheb Mahomed Ghouse, Extra-Assistant Conservator of Forests, Balaghat Forest Division, is granted three months' privilege leave, under Article 291 of the Civil Service Regulations, from such date as he may be relieved of his duties by Mr. Ramchandra, Extra-Assistant Conservator of Forests. On the expiration of the three months' privilege leave, granted him, Khan Saheb Mahomed Ghouse, is posted to the Raipur Forest Division, of which he will assume charge.

27th July, 1892.—No. 2640.—Mr. R. C. Thompson, Probationary Extra-Assistant Conservator of Forests, is temporarily attached to the Nagpur Division, which he joined (on return from the Forest School) on the 14th April 1892.

No. 2641.—Mr. R. C. Thompson, is transferred from the Nagpur Division to the Pranhita-Godavari Sub-Division of the Chanda Division.

No. 2642.—Mr. P. E. Clutterbuck, Assistant Conservator of Forests, on being relieved of the charge of the Pranhita-Godavari Sub-Division, is appointed to be Working Plans Officer.

No. 2643.—Mr. P. H. Clutterbuck, Assistant Conservator of Forests, and Mr. R. C. Thompson, Probationary Extra-Assistant Conservator of Forests, respectively surrendered and received charge of the Pranhita-Godavari Sub-Division on the afternoon of the 10th June, 1892.

No. 2644.—Mr. H. B. Anthony, Deputy Conservator of Forests, availed himself, on the forenoon of the 8th June 1892, of the leave granted him by Notification No. 1877 of of the 9th June 1892, making over charge of his office to the Deputy Commissioner, Raipur.

27th July, 1892.—No. 2645.—Pending the return from leave of Mr. H. B. Anthony, or until further orders, Mr. P. H. Clutterbuck, is appointed to the charge of the Raipur Division, in addition to his other duties.

No. 2646.—Colonel W. S. Brooke, Deputy Commissioner, Raipur and Mr. P. H. Clutterbuck, Assistant Conservator of Forests, respectively surrendered and received charge of the Raipur Forest Division on the forenoon of the 24th June, 1892.

8.—BURMA GAZETTE.

25th July, 1892.—No. 220.—Mr. G. R. Long, Assistant Conservator of Forests, is transferred from Tharrawaddy to the Toungoo division.

28th July, 1892.—No. 221.—Mr. W. F. L. Tottenham, Assistant Conservator of Forests, is transferred from Bassein to the charge of the Thayetmyo Forest division.

No. 222.—Under the provisions of Article 340 (b) of the Civil Service Regulations Mr. F. W. Thellusson, Deputy Conservator of Forests, is granted furlough for 15 months, with effect from the 1st August, 1882, or the subsequent date on which he may avail himself of it.

No. 223.—The following temporary alterations of rank are ordered in the Forest Department :—

(1) With effect from the 10th June, 1892, consequent on the departure on furlough of Mr. J. Copeland, Deputy Conservator :

Mr. H. C. Hoghton, Deputy Conservator, 4th (officiating 3rd) grade, to officiate as Deputy Conservator, 2nd grade.

Mr. C. H. Hobart-Hampden, Deputy Conservator, 4th (officiating 3rd) grade, to officiate as Deputy Conservator, 2nd grade.

Mr. G. F. R. Blackwell, Assistant Conservator, 1st (officiating Deputy Conservator, 4th) grade, to officiate as Deputy Conservator, 3rd grade.

Mr. C. W. A. Bruce, Assistant Conservator, 2nd (officiating 1st) grade, to officiate as Deputy Conservator, 4th grade.

(2) With effect from the 19th June, 1892, consequent on the return from privilege leave of Mr. H. C. Hoghton, Deputy Conservator :

Mr. C. H. Hobart-Hampden, Deputy Conservator, 4th (officiating 2nd) grade, to officiate as Deputy Conservator, 3rd grade.

Mr. G. F. R. Blackwell, Assistant Conservator, 1st (officiating Deputy Conservator, 3rd) grade, to officiate as Deputy Conservator, 4th grade.

Mr. C. W. A. Bruce, Assistant Conservator, 2nd (officiating Deputy Conservator, 4th) grade, to officiate as Assistant Conservator, 1st grade.

(3) With effect from the 8th July, 1892, consequent on the departure on privilege leave of Mr. C. W. Palmer, Deputy Conservator :

Mr. F. W. Thellusson, Deputy Conservator, 2nd, to officiate as Deputy Conservator, 1st grade.

Mr. C. H. Hobart-Hampden, Deputy Conservator, 4th, to officiate as Deputy Conservator, 2nd grade.

Mr. G. F. R. Blackwell, Assistant Conservator, 1st, to officiate as Deputy Conservator, 3rd grade.

Mr. C. W. A. Bruce, Assistant Conservator, 2nd, to officiate as Deputy Conservator, 4th grade.

4th August, 1892.—No. 224.—Under the provisions of Article 291 of the Civil Service Regulations privilege leave for for two months is granted to Mr. C. W. A. Bruce, Assistant Conservator of Forests, with effect from the 1st September, 1892, or the subsequent date on which he may avail himself of it.

No. 225.—Mr. C. M. Burn-Murdoch, Assistant Conservator of Forests, is transferred from Taungdwingyi to the charge of the Minbu Forest division during the absence of Mr. C. W. A. Bruce on privilege leave, or until further orders.

No. 226.—Mr. R. F. Lewis, Extra Assistant Conservator of Forests, is temporarily transferred from the Ruby Mines subdivision of

the Katha Forest division to the Pyinmana subdivision of the Pyinmana Forest division.

29th July, 1892.—No. 14.—With reference to Revenue Department Notification No. 220, dated Rangoon, the 25th July, 1892, Mr. G. R. Long, Assistant Conservator of Forests, made over charge of his duties in the Tharrawaddy division on the forenoon of the 28th July 1892.

9th August, 1892.—No. 31.—The Chief Commissioner directs that, with effect from the 1st September, 1892, the Chindwin Forest division shall be divided into two divisions, to be called respectively the Upper Chindwin Forest division, with headquarters at Kindat, and the Lower Chindwin Forest division, with headquarters at Monywa.

The local limits of the Upper Chindwin Forest division shall be those of the Upper Chindwin district, excluding on the west of the Chindwin river that portion which is drained by the Myittha river and the Palusawa creek and their tributaries, and on the east of the Chindwin river the portion of the district drained by the Mèsein creek and its feeders, and the part of the district which lies to the south of that stream. They will also include that portion of the Katha district which is drained by tributaries of the Chindwin river.

The local limits of the Lower Chindwin Forest division shall include so much of the Upper Chindwin district as is not included in the Upper Chindwin Forest division, that portion of the Lower Chindwin district which is drained by the Chindwin river, that portion of the Pakokku district which is drained by the Myittha river and the Taungdwin creek, and that portion of the Ye-u district of which the drainage is into the Chindwin river above Monywa.

No. 232.—Mr. H. H. Forteath, Assistant Conservator of Forests, is appointed to the charge of the Upper Chindwin Forest division.

No. 233.—Mr. H. N. Thompson, Assistant Conservator of Forests, is appointed to the charge of the Lower Chindwin Forest division.

No. 234.—Under the provisions of clause (b) of section 35 of the Burma Forest Act, 1881, the Chief Commissioner declares that from the date of this notification the undermentioned trees standing on any land at the disposal of Government shall be reserved trees within the local limits hereinafter named :

Kanyin }
Thingan } in all districts of the Arakan Commissionership.

No. 235.—Under the provisions of Article 369 of the Civil Service Regulations leave on medical certificate for 25 days is granted to Maung Shwe Ka, Extra Assistant Conservator of Forests, with effect from the 19th May, 1892 to the 13th June, 1892, in extension of the leave granted him in this department Notification No. 96, dated the 17th May 1892.

8th August, 1892.—No. 15.—With reference to Revenue Department Notification Nos. 116 and 117, dated the 29th March, 1892, Mr. W. F. L. Tottenham, Assistant Conservator of Forests, and Mr. H. B. Ward, Deputy Conservator of Forests, respectively made over and received charge of the Western division on the forenoon of the 2nd instant.

11th August, 1892.—No. 16.—With reference to Revenue Department Notifications Nos. 221 and 222, dated Rangoon, the 8th July,

1892, Messrs. F. W. Thellusson, Deputy Conservator of Forests, and W. F. L. Tottenham, officiating Deputy Conservator of Forests, respectively made over and received charge of the Thayetmyo division on the afternoon of the 9th instant.

9.—ASSAM GAZETTE.

4th August, 1892.—No. 6839G.—Mr. J. C. Kelly, Extra Assistant Conservator of Forests, received charge of the Darrang Forest Division from Mr. D. P. Copeland on the afternoon of the 24th July, 1892.

4th August, 1892.—No. 6850.—Mr. D. P. Copeland, Deputy Conservator of Forests, made over charge of the Kamrup Forest Division to Mr. A. M. Long, Assistant Conservator of Forests, on the afternoon of the 27th July, 1892.

5th August, 1892.—No. 6884G.—In order that effect may be given to the re-organisation scheme of the Indian Forest Service, as finally sanctioned by the Government of India in Revenue and Agricultural Department Circular No. 30F., dated the 29th December 1891, the following appointments and officiating appointments in the Upper Controlling Staff of the Forest Department in Assam are notified :

(1) With effect from the 26th February, 1891, the date from which the Chief Commissioner introduces the new scheme into Assam :—

Mr. J. T. Jellicoe, Officiating Deputy Conservator, First Grade, to be Deputy Conservator, First Grade, *vice* Mr. E. E. Fernandez, seconded.

Mr. A. J. Mein, Deputy Conservator, Third Grade, to officiate as Deputy Conservator, Second Grade.

Mr. C. G. C. Fordyce, Deputy Conservator, Fourth Grade, to officiate as Deputy Conservator, Third Grade.

Mr. T. J. Campbell, Assistant Conservator, First Grade, to be Deputy Conservator, Fourth Grade.

Mr. H. G. Young, Assistant Conservator, First Grade, to officiate as Deputy Conservator, Fourth Grade.

Mr. C. P. Fisher, Officiating Assistant Conservator, First Grade, to officiate as Deputy Conservator, Fourth Grade, *vice* Mr. T. J. Campbell, on leave.

(2) With effect from the 1st May, 1891, in consequence of Mr. J. T. Jellicoe officiating as Conservator—

Mr. A. J. Mein, Officiating Deputy Conservator, Second Grade, to officiate as Deputy Conservator, First Grade.

M. C. G. D. Fordyce, Officiating Deputy Conservator, Third Grade, to officiate as Deputy Conservator, Second Grade.

Mr. D. P. Copeland, Deputy Conservator, Fourth Grade, to officiate as Deputy Conservator, Third Grade.

(3) With effect from the 7th of May, 1891, in consequence of Mr. A. J. Mein going on leave—

Mr. C. G. D. Fordyce, Officiating Deputy Conservator, Second Grade, to officiate as Deputy Conservator, First Grade.

Mr. D. P. Copeland, Officiating Deputy Conservator, Third Grade, to officiate as Deputy Conservator, Second Grade.

Mr. H. G. Young, Officiating Deputy Conservator, Fourth Grade, to officiate as Deputy Conservator, Third Grade.

(4) With effect from the 1st September, 1891, in consequence of Mr. J. T. Jellicoe reverting to Deputy Conservator, First Grade—

Mr. C. G. D. Fordyce, Officiating Deputy Conservator, First Grade, to revert to Officiating Deputy Conservator, Second Grade.

Mr. D. P. Copeland, Officiating Deputy Conservator, Second Grade, to revert to Officiating Deputy Conservator, Third Grade

Mr. H. G. Young, Officiating Deputy, Conservator, Third Grade, to revert to Officiating Deputy Conservator, Fourth Grade.

(5) With effect from the 19th of September, 1891, the date from which he passed his Departmental examinations—

Mr. W. F. Lloyd, Assistant Conservator, Second Grade, to officiate as Deputy Conservator, Fourth Grade, *vice* Mr. Copeland acting as Deputy Conservator, Third Grade.

(6) With effect from the 16th November, 1891, in consequence of the return of Mr. J. Campbell from leave—

Mr. W. F. Lloyd, Officiating Deputy Conservator, Fourth Grade, to revert to Assistant Conservator, Second Grade, but to officiate as Assistant Conservator, First Grade, *vice* Mr. C. P. Fisher.

(7) With effect from the 4th December, 1891, in consequence of M. J. T. Jellicoe proceeding on privilege leave—

Mr. C. G. D. Fordyce, Officiating Deputy Conservator, Second Grade, to officiate as Deputy Conservator, First Grade.

Mr. D. P. Copeland, Officiating Deputy Conservator, Third Grade, to officiate as Deputy Conservator, Second Grade.

Mr. T. J. Campbell, Deputy Conservator, Fourth Grade, to officiate as Deputy Conservator, Third Grade.

Mr. W. F. Lloyd, Officiating Assistant Conservator, First Grade, to officiate as Deputy Conservator, Fourth Grade.

(8) With effect from the 29th December, 1891, in consequence of transfers made in Revenue and Agricultural Department Notification No. 1348F., dated the 29th December, 1891—

Mr. W. E. D'Arcy, Deputy Conservator, Second Grade, to be Deputy Conservator, First Grade.

Mr. C. G. D. Fordyce, Officiating Deputy Conservator, First Grade, to be Deputy Conservator, Third Grade, but to continue to officiate as First Grade Deputy Conservator, owing to Mr. Fernandez being seconded, and Mr. D'Arcy officiating as Conservator in the North-Western Provinces.

Mr. A. M. Reuther, Deputy Conservator, Fourth Grade, to officiate as Deputy Conservator, Second Grade.

Mr. D. P. Copeland, Officiating Deputy Conservator, Second Grade, to officiate as Deputy Conservator, Third Grade.

Mr. T. J. Campbell, Officiating Deputy Conservator, Third Grade, to revert to his substantive appointment as Deputy Conservator, Fourth Grade.

(9) With effect from the 2nd March, 1892, in consequence of transfers made in Government of India, Revenue and Agricultural Department, Notification No. 612F., dated the 20th May, 1892.—

Mr. R. H. M. Ellis, Deputy Conservator, Second Grade, to be Deputy Conservator, First Grade, *vice* Mr. Fernandez, seconded.

Mr. J. L. Pigot, Deputy Conservator, Third Grade, to be Deputy Conservator, Second Grade, *vice* Mr. Ellis, promoted, and to be seconded.

Mr. D. P. Copeland, Officiating Deputy Conservator, Third Grade, to be Deputy Conservator, Second Grade, *vice* Mr. Pigot, seconded.

Mr. H. G. Young, Officiating Deputy Conservator, Fourth Grade, to be confirmed in that grade.

Mr. J. E. Barrett, Assistant Conservator, First Grade, to be Deputy Conservator, Fourth Grade.

M. W. F. Lloyd, Officiating Deputy Conservator, Fourth Grade, to be confirmed in that grade.

(10) The following Notifications are hereby cancelled :—

Notification No.	5683G.,	dated the 9th July, 1891.
"	"	5786G., dated the 10th July, 1891.
"	"	5971G., dated the 17th July, 1891.
"	"	8277G., dated the 29th September, 1891.
"	"	9874G., dated the 25th November, 1891.
"	"	11015G., dated the 31st December, 1891.
"	"	1977G., dated the 10th March, 1892.

10th August, 1892.—No. 7017G.—Mr. R. H. M. Ellis, Deputy Conservator of Forests, received change of the Lakhimpur Forest Division from Mr. C. G. D. Fordyce, Deputy Conservator of Forests, on the forenoon of the 27th July 1892.

3rd August, 1892.—No. 3648R.—*Erratum*.—In Notification No. 31, dated the 1st October 1879, published at page 572 of the *Assam Gazette* of the 4th October 1879, for the words "Sub-Assistant Conservators" substitute "Extra Assistant Conservators."

11th August, 1891.—No. 7108G.—*Erratum*.—In Notification No. 6884G., dated the 5th August, 1892, publish at page 482 of the *Assam Gazette* of the 6th idem, insert the following as paragraph (8)A :

With effect from the 2nd March, 1892, in consequence of Revenue and Agricultural Department Notifications Nos. 550F, and 612F., dated the 13th and 20th, May 1892, respectively—

Mr. J. L. Pigot, Deputy Conservator, Third Grade, to officiate as Deputy Conservator, Second Grade, *vice* Mr. A. M. Reuther, re-transferred to the Punjab.

In paragraph 9 of the same Notification for the words "2nd March" read "16th May"; and for the portion beginning—

"Mr. J. E. Barrett, Assistant Conservator, First Grade," down to the end of the paragraph, read—

"Mr. J. E. Barrett, Assistant Conservator, First Grade, to be substantive Deputy Conservator, Fourth Grade, *vice* Mr. D. P. Copeland, promoted.

"Mr. W. Lloyd, Officiating Deputy Conservator, Fourth Grade, to be Assistant Conservator, First Grade, *vice* Mr. H. G. Young, promoted, and to be substantive Deputy Conservator, Fourth Grade."

17th August, 1892.—No. 7234G.—Mr. R. H. M. Ellis, Deputy Conservator of Forests, in charge of the Lakhimpur Forest Division is placed in charge of the Sibsagar Forest Division, in addition to his own duties, until further orders.

17th August, 1892.—No. 7235G.—Mr. R. H. M. Ellis, Deputy Conservator of Forests, received charge of the Sibsagar Forest Division on the afternoon of the 4th August, 1892.

22nd August, 1892.—No. 7352G.—Mr. D. P. Copeland, Deputy Conservator of Forests, having passed in the Garo language according to the tests laid down in the rules prescribed by General Department Notification No. 255, dated the 17th July, 1887, for the examination of Forest Officers, is presented with the authorised reward of Rs. 500.

25th August, 1892.—No. 7490G.—Privilege leave of absence for eighteen days, under article 291 of the Civil Service Regulations, is granted to Mr. W. F. Lloyd, Deputy Conservator of Forests, in charge of the Working Plans Division, with effect from the 10th October, 1892, or the subsequent date on which he may avail himself of it.

11.—MYSORE STATE GAZETTE.

13th July, 1892.—No. 1716—G. 422-92.—Mr. G. Rama Rao, Forest Probationer on Special duty in the Kolar District, is granted 2 days' casual leave from such date as he may avail himself of the same.

18th August, 1892.—No. 2704.—G. 675-92.—Mr. H. Muttappa, Sub-Assistant Conservator of Forests, Hassan District, having availed himself of the 2 weeks privilege leave of absence granted to him in Notification No. 70 of the 17th May, 1892, from the 6th June, 1892 and returned to duty on the forenoon of the 21st idem, the said leave is hereby extended by one day.

VIII.—EXTRACTS FROM OFFICIAL GAZETTES.

2.—MADRAS GAZETTE.

8th August, 1889.—The following passed the Departmental Test in Forest Law, Code and Accounts held in July, 1892 :—

Forester N. Sundaram, Vizagapatam District,

U. Ramachendra Rao, Kurnool District.

26th August, 1892.—The three months' sick leave granted to Acting Ranger Mr. Blacker and notified in page 1096 of Part II of the *Fort St. George Gazette*, dated 2nd August, 1892, is commuted into privilege leave, under article 291 of the Civil Service Regulations.

3rd September, 1892.—Leave on Medical Certificate. Ranger Mr. Bower, for ten days, from 25th August, 1892, under article 369 of the Civil Service Regulations.

9th September, 1892.—No. 427.—Mr. A. W. Lushington, Deputy Conservator of Forests, Madras, has been permitted by the Right Honorable the Secretary of State for India to return to duty within the period of his leave.

9th September, 1892.—No. 421.—Mr. E. R. Murray, Deputy Conservator of Forests, Fourth Grade, to be District Forest Officer, Kurnool,

9th September, 1892.—No. 422.—Mr. P. M. Lushington, Assistant Conservator of Forests, First Grade (acting), to be District Forest Officer, Godavari.

15th September, 1891.—No. 436.—The examination leave granted to Mr. Thornton, Assistant Conservator of Forests, Second Grade, as per page 1105 of the *Fort St. George Gazette*, dated August 30th, 1892, is cancelled, and in lieu of it examination leave for three months is granted to him with effect from or after 20th October, 1892.

15th September, 1892.—No. 437.—Under article 291 of the Civil Service Regulations, 2nd Edition, privilege leave for twenty-six days, from 25th June 1892, is granted to Mr. C. DuPré Thornton, Assistant Conservator of Forests, Second Grade, and District Forest Officer, Tinnevely.

15th September 1892.—No. 438.—Mr. S. O. Moss, Extra Assistant Conservator of Forests, Second Grade, is appointed to act as District Forest Officer of Tinnevely during the absence of Mr. Thornton on examination leave, or until further orders.

22nd September 1892.—No. 448.—Mr. A. W. Peet, Conservator of Forests, Madras, has been permitted by the Right Honorable the Secretary of State for India to return to duty within the period of his leave.

22nd September 1892.—V. Kalyanarama Aiyar, Probationary Ranger, Fifth Class, Anantapur District, is confirmed in that appointment.

31st August, 1892.—No. 6943.—Mr. G. M. Ryan, Divisional Forest Officer, Sukkur, held charge of the Jerruck Forest Division, in addition to his own, from 15th May, to 14th June, 1892, both days inclusive.

3.—BOMBAY GAZETTE.

2nd September, 1892.—Mr. W. R. Gaunde, Extra Conservator of Forests, delivered over charge of his duties in the Conservator's Office on the afternoon of the 16th August, and received that of the Sub-Division Office, Nasik, from Mr. W. A. Wallinger, Extra Assistant Conservator of Forests, on the 19th idem, after office hours.

Messrs. C. G. Dalia, acting Extra-Assistant Conservator of Forests, Fourth Grade, and W. A. Wallinger, Extra Assistant Conservator of Forests, Second Grade, respectively delivered over and received charge of the Divisional Forest Office, Surat, on the afternoon of the 20th August.

6th September, 1892.—No. 7107.—In exercise of the power conferred by Section 75 (a) of the Indian Forest Act VII, of 1878, and of other powers enabling him in this behalf, the Governor in Council is pleased to make the following rules, in supersession of all previous rules on the same subjects, for prescribing and limiting the powers and duties of Forest Officers under the said Act :—

1. Forest administration, as a branch of land-revenue administration, is under the chief controlling authority which, by Section 4 of the Bombay Land Revenue Code, 1879, is vested in the Commissioner, subject to the Governor in Council. All Forest Officers, as well as Revenue Officers, who are concerned in the management of forests, are therefore subject in all matters relating to forest administration to the Commissioner.

2. The Collector of each district, in subordination to the Commissioner and subject to the orders of Government, is responsible for the due management of the forests therein; and for this purpose all Forest Officers within the district shall be subject to the orders of the Collector. Divisional Forest Officers will be Assistants to the Collector for forest purposes.

All Divisional Forest Officers and their subordinates shall in all but purely technical matters be subordinate to the Collector of the district in which they are serving.

3. The duties and powers of Assistant and Deputy Collectors in charge of talukas in respect of forest matters shall be regulated by the same provisions which are laid down in Section 10 of the Bombay Land Revenue Code, 1879, in respect of revenue administration generally.

4. Subject to the other provisions of these rules, each Conservator of Forests in his own circle or Deputy Conservator in independent charge of a circle is invested with the direction of all professional operations of technical forestry.

5. Except in so far as is otherwise directed in rules or orders of Government, the departmental control of all Forest Officers in a circle vests in the Conservator of Forests of that Circle or in that of the Deputy Conservator in independent charge of a circle.

6. Divisional Forest Officers shall, in the posting and distribution of the subordinate forest establishment, comply with any orders they may receive from the Collector.

7. No appointments to offices higher than that of round guard shall be made by the Conservator or other Forest Officer without consulting and obtaining the consent thereto of the Collector of the District.

8. In all matters relating to local supply or the rights and privileges of the people in or in respect of forests, orders shall be issued by the Collector alone and not by any Forest Officer, and such orders shall be communicated to those concerned through the ordinary revenue channels.

This rule applies also to pastures and fodder reserves, the management and control of which is vested exclusively in the Collector, subject to the orders of the Commissioner and of Government, and with respect to which the Conservator of Forests is to act in the capacity of consultative officer only, advising and giving his opinion on all questions of a professional or technical character referred to him by any of the said authorities.

9. No forest compartment shall be closed, whether for planting or reboisement or for punitive purposes, except under the order or with the approval of the Collector.

This rule does not apply to the closure of compartments which have been recently felled in strict accordance with a duly sanctioned working plan.

10. All orders issued by a Conservator to any Divisional Forest Officer and all correspondence between the Conservator and any such officer shall be forwarded through the Collector, who will record such remarks thereon or, in matters other than such as are described in rule 4, give such directions with regard thereto as he thinks fit.

In the event of a difference of opinion between a Collector and the Conservator of Forests, either officer may refer the matter to the Commissioner, who will either dispose of the reference himself, or, if he thinks it necessary, obtain the orders of Government.

11. In matters relating to departmental finance or to appointment, transfer, or leave of establishment, in which the orders of Government are required, a Conservator may report to Government direct.

12. Every Divisional Forest Officer shall prepare and submit, before the end of June or middle of July in each year, the provisional plan of operations, which he proposes to carry out in the ensuing year in the area under his official charge, to the Collector of the District.

13. The Collector shall—

(a) consider all plans submitted to him under the last preceding rule, with special reference to any proposed closure of forest areas against grazing or other privileges, and shall see that due provision is made for local wants, and

(b) if he considers any such plans open to objection in such connection, shall return the same with any comments, and for compliance with any directions he may make, to the officer by whom they may have been submitted.

14. The Collector shall forward to the Conservator of the Circle such plans as meet with his approval.

15. Before the commencement of each season information as to the principal operations to be carried out in each district shall be communicated to the Collector thereof.

16. It shall be the duty of the local Forest Officers to inform the Collector as to the places where any cutting is to be made, or special protection is needed, so that the Collector may make known, through his Assistants and other subordinates, to the local public the places :

(a) where supplies of wood, grass or rab, &c., may be obtained, and

(b) where the grazing of cattle is prohibited or allowed.

17. It shall be the duty of all Revenue Officers to give every possible assistance to the Divisional Forest Officers by giving information of all cases of forest fires or of offences committed in forests, and of any neglect of duty by forest subordinates which may come to their notice, and to impress on their subordinates a sense of their obligation to protect the Government forests against theft or injury.

18. It shall be the duty of the Collector and his Assistants from time to time to inspect the offices and accounts of all Rangers within their charge, taking care that range officers are not withdrawn from important out-door duties to attend inspections.

19. Letters from a Divisional Forest Officer to a Mámíátdar should ordinarily be sent through the Assistant Conservator in charge.

20. Orders by Forest Officers to village officers shall ordinarily be sent through the Mámíátdar to whom the village officers are subordinate, but may, if urgent, be sent direct, provided that in every such case copies of the order shall at the same time be sent to the Assistant Collector in charge and to such Mamlatdar as aforesaid.

21. Compartments of a forest block shall be felled in regular rotation as they fall due.

22. (1) If it becomes necessary to delay the felling of a compartment beyond the time at which such felling would, according to regular rotation be due, the Collector of the District shall, in consultation with the Conservator of the Circle and subject to the sanction of the Commissioner of the Division, make arrangements for meeting the requirements of the villagers in the locality.

(2) For such purpose the villagers may, if necessary, and if no other arrangement is practicable, be permitted to enter the compartment the felling whereof has been so delayed and lop for themselves the material to which, but for such delay, they would have been entitled.

23. When a Maháikari or Chief Constable, or any Revenue or Police Officer of higher rank camps in the limits of a forest village or "in the limits of a forest beat or round," the Forest Guard shall report himself to such officer and bring his diary with him for inspection.

A Forest Guard need not report himself more than once to the same officer in one season, but should present himself on other occasions if sent for.

24. The officer to whom report is made should, time permitting, inspect the Forest Guard's diary, and put such questions to him as may seem expedient with a view to ascertaining whether he is attentive to his duties. The village officers should also be questioned on the point.

A Revenue or Police Officer examining a Forest Guard's diary shall write the word "seen" below the last entry, attaching his signature and the date of inspection.

25. Time and opportunity permitting, the officers named should visit any forest block, plantation or special work in charge of the Forest Guard, who should, if possible, attend such officer on his visit.

26. No Revenue or Police officer shall call a Forest Guard off his beat, nor shall a Forest Guard leave his beat in order to report himself to such officer.

27. Rule 24, 25 and 26 do not apply to Collectors, or Commissioners, who will exercise their own discretion in the matters therein dealt with.

28. Subject to the orders of Government—

(a) the Commissioner in Sind shall have the direction, regulation and general control of all matters other than financial connected with forest administration in that province;

(b) the Commissioners of the Northern, Central and Southern Division shall be responsible for the entire executive administration of forest affairs within their respective divisions, and shall for the purpose of such administration—

(a) issue orders and instructions to Collectors, Conservators and Deputy Conservators in independent charge of circles;

(b) interpret the orders of Government whenever doubts may arise in applying such orders;

(c) settle all matters in which any difference of opinion arise between the Forest Department and other departments;

(d) promote generally the harmonious working of the Revenue and Forest Departments; and

(e) except in matters relating to departmental finance and to appointment, leave or transfer of establishment, in which the orders of Government are required, receive, consider and with their own views in each case, when such reference is necessary, refer to Government all reports respecting forest matters submitted to them whether from the Revenue or from the Forest Department.

15th September, 1892.—Messrs. B. J. Haselden and T. R. D. Bell, Assistant and Deputy Conservators, respectively delivered over and received charge of the Divisional Forest Office, Central Division of Kánara on the afternoon of the 7th instant.

20th September, 1892.—Messrs. F. Gleadow and A. D. Wilkins, Deputy Conservators of Forests, respectively delivered over and received charge of the office of the Divisional Forest Officer, Poona, on the 11th September, 1892, before office hours.

19th September, 1892.—Messrs. G. A. Hight and W. R. Woodrow, Deputy Conservators, respectively delivered over and received charge of the Dhárwár Divisional Forest Office on the forenoon of the 14th instant.

4.—BENGAL GAZETTE.

27th September, 1891.—No 3548F.—Consequent on the grant of three months' privilege leave to Mr. C. A. G. Lillingston, Officiating Deputy Conservator, third grade, with effect from the 11th July 1892, the following promotions are made in the Upper Controlling Staff of the Bengal Forest Department from that date :—

Mr. C. G. Rogers, Deputy Conservator, fourth grade, on deputation to the Forest School (seconded), to officiate as Deputy Conservator, third grade.

Mr. H. D. D. French, Deputy Conservator, fourth grade, to officiate as Deputy Conservator, third grade, *vice* Mr. C. G. Rogers, seconded.

5.—N.-W. P. AND OUDH GAZETTE.

21st September, 1892.—No. 4390C.—The undermentioned officer has been granted by Her Majesty's Secretary of State for India permission to return to duty :—

Name.	Service.	Appointment.	Date on which permitted to return.
Mr. F. B. Bryant,	Indian Forest.	Deputy Conservator of Forests.	Within the period of his leave.

6.—PUNJAB GAZETTE—

29th August, 1892.—No. 408.—Mr. C. Somers-Smith, Assistant Conservator of Forests, has been attached to the Chamba Division with effect from the 11th August, 1892.

No. 413.—Messrs. E. R. Murray and R. J. P. Pinder, Officiating Deputy Conservators of Forests, respectively made over and received charge of the Jhelum Forest Division on the afternoon of the 11th August, 1892, consequent on the transfer of the former officer to Madras to and his departure on two months privilege leave granted him by the Madras Government.

23rd September, 1892—No. 725.—Mr. J. H. Lace, Deputy Conservator of Forests, Punjab, has obtained one month's privilege leave, under Article 291 of the Civil Service Regulations, with effect from the forenoon of the 19th September, 1892.

7.—CENTRAL PROVINCES GAZETTE.

30th August, 1892.—No. 3113.—Leave on medical certificate for one year, under Article 369 of the Civil Service Regulations, is granted to Dr. E. Dobbs, Deputy Conservator of Forests, with effect from the date on which he may avail himself of it.

Notification No. 2753, dated the 5th instant, is hereby cancelled.

No. 3114.—Consequent on the grant of leave to Dr. E. Dobbs, Deputy Conservator of Forests, Mr. V. S. Menzies, Assistant Conservator of Forests, Nagpur-Wardha Division, is transferred to the Seoni Division, of which he will assume charge.

No. 3115.—During the absence of Mr. Menzies, Assistant Conservator of Forests, or until further orders, Mr. H. S. K. Edie, Assistant Conservator of Forests, will hold charge of the Nagpur-Wardha Forest Division.

5th September, 1892.—No. 3177.—In consequence of the amalgamation of the controlling staff of the Forest Department of the Punjab, with those of the Central Provinces, Berar and Coorg, in accordance with Government of India Circular No. 30-F., dated the 29th December, 1891, the following list is published, showing the names and position of the officers on the combined lists on the 29th December, 1891 :—

Serial number in list.	Name.	Position.
For details see Punjab Gazette Notification No. 379 dated 20th August, 1892, in September 1892 number of <i>Indian Forester</i> .		

5th September 1892.—No. 3178.—Consequent on the appointment to the Central Provinces of Mr. H. S. K. Edie, *vide* Government of India Notification No. 532-F., dated the 6th May, 1892, amalgamated list of the Punjab, Central Provinces, Berar and Coorg will, on the 31st December, 1891, stand as follows :—

Serial number in list.	Name.	Position.
For details, see Punjab Gazette Notification No. 380 dated 20th August, 1892, in September 1892 number of the <i>Indian Forester</i> .		

5th September, 1892.—No. 3179.—Consequent on the transfer to the Imperial List of Mr. A. E. Wild, on his appointment as Conservator of Forests, 3rd grade, *vide* Government of India Notification No. 526-F., dated the 6th May, 1892, the following promotions shall have effect from the 17th January, 1892 :—

For details see Punjab Gazette Notification No. 381 dated 20th August, 1892, as above.

5th September, 1892.—No. 3180.—Consequent on the departure of Mr. F. S. Barker, Officiating Deputy Conservator of Forests, 3rd grade, on leave on medical certificate for 12 months, the following promotions shall have effect from the 22nd January, 1892 :—

For details see Punjab Gazette Notification No. 382, dated 20th August, 1892, as above.

5th September, 1892.—No. 3181.—Consequent on the return from furlough of Mr. W. King, Deputy Conservator of Forests, 4th grade, the following changes shall have effect from the 8th February 1892 :—

For details see Punjab Gazette Notification No. 383 dated 20th August, 1892, as above.

5th September, 1892.—No. 3182.—Consequent on the return from leave of Mr. G. S. Hart, Assistant Conservator Forests, 1st grade, the following changes shall have effect from the 13th February, 1892 :—

For details see Punjab Gazette Notification No. 384 dated 20th August, 1892, as above.

5th September, 1892.—No. 3183.—Consequent upon the death of Mr. A. J. Mein, Deputy Conservator of Forests, 3rd grade, the re-transfer from Assam to the Punjab of Mr. A. M. Reuther, Deputy Conservator of Forests, 4th grade, and the transfer of Mr. J. L. Pigot, Deputy Conservator of Forests, 4th grade, from the Central Provinces to Assam, the following changes shall have effect from the 2nd March, 1892 :—

For details see Punjab Gazette Notification No. 385, dated 20th August, 1892, as above.

5th September 1892.—No. 3184.—Consequent on the appointment of Mr. R. H. E. Thompson, Deputy Conservator of Forests, 1st grade, as Conservator of Forests, 3rd grade, *vide* Government of India Notification No. 594-F., dated the 20th May, 1892, the following promotions shall have effect from the 4th April, 1892 :—

For details see Punjab Gazette Notification No. 386, dated 20th August, 1892, as above.

5th September, 1892.—No. 3185.—Consequent on the return from deputation in the Patiala State of Mr. G. G. Minniken, Deputy Conservator of Forests, 2nd grade, the following changes shall have effect from the 5th May, 1892 :—

For details see Punjab Gazette Notification No. 387 dated 20th August, 1892, as above.

5th September, 1892.—No. 3186.—Consequent on the departure on three months' privilege leave of Mr. H. B. Anthony, Deputy Conservator of Forests, 4th grade, the following promotion shall have effect from the 8th June, 1892 :—

For details see Punjab Gazette Notification No. 388, dated 20th August, 1892, as above.

8th September 1892.—No. 3221.—With reference to *Central Provinces Gazette* Notification No. 3114, dated the 30th August, 1892, Messrs. E. Dobbs, Deputy Conservator of Forests, and V. S. Menzies, Assistant Conservator of Forests, respectively surrendered and received charge of the Seoni Forest Division on the forenoon of the 16th August, 1892.

No. 222.—With reference to *Central Provinces Gazette* Notification No. 3115, dated the 30th August, 1892, Messrs. V. S. Menzies and H. S. K. Edie, Assistant Conservators of Forests, respectively surrendered and received charge of the Nagpur Forest Division on the afternoon of the 12th August, 1892.

5th September 1892.—Mohan Lall, Forest Ranger, in the Mandla Forest Division, is reduced from the 1st grade of Forest Ranger on Rs. 120 per mensem, to Forest Ranger, 2nd grade, on Rs. 100 per mensem, with effect from the 23rd May, 1892,

Syed Ali Muttaki, Forest Ranger, 2nd grade, in the Mandla Forest Division, is promoted to Forest Ranger, 1st grade, with effect from the 23rd May, 1892, *vice* Mohan Lall, Forest Ranger, reduced.

13th September 1892.—Mr. S. R. Parsons, a passed private student of the Imperial Forest School, Dehra Dún, is appointed Forest Ranger, 5th grade, on a salary of Rs. 60 per mensem, with effect from the 15th August, 1892, and is posted to the Jubbulpore Forest Division.

8.—BURMA GAZETTE.

25th August, 1892.—No. 248.—Mr. W. A. Hearsey, Extra Assistant Conservator of Forests, 4th grade, on probation, is confirmed in his appointment with effect from the 7th June, 1891.

No. 249 (*Corrigendum*).—In the first line of the rule published in this department Notification No. 1, dated the 7th January, 1892, for "5(a)" read "15(a)."

27th August, 1892.—No. 252.—Mr. E. B. Powell, Extra Assistant Conservator of Forests, on probation, is transferred from Myanaung to Tharrawaddy.

29th August, 1892.—No. 253.—In exercise of the powers conferred by section 34, sub-section (2), clause (h) of the Upper Burma Forests Regulation, 1887, the Chief Commissioner directs that the following rule shall be substituted for the rule published in Revenue Department Notification No. 180 (Forests), dated the 27th August, 1891:—

16d) The following rules are prescribed for the tapping of India-rubber trees in the Bhamo and Upper Chindwin districts:—

Trees may be tapped only during the mouths of December, January, February, and March; stems or aerial roots measuring less than 3 feet in girth at 3 feet above the ground, as well as the underground roots of trees and the lowest part of the stems within 3 feet from the ground may not be tapped, and no India-rubber trees may be felled, burnt, or lopped. The incisions must be not less than 2 feet apart and must not exceed 1 foot in length and 4 inches in breadth.

No. 254.—In exercise of the powers conferred by section 34 of the Upper Burma Forest Regulation, 1887, the Chief Commissioner directs that, with effect from the 1st January, 1893, the following rule shall be substituted for Rule 17 of the rules under the Regulation published in Revenue Department Notification No. 59, dated the 11th April, 1889:—

(17) Upon all bamboos and canes brought to a revenue station, duty at the rate of $12\frac{1}{2}$ per cent. *ad valorem* shall be paid.

A duty at the rate of 12 annas per viss ($3\frac{1}{2}$ lbs.) on all India-rubber extracted shall also be paid at the first revenue station reached.

31st August, 1892.—No. 255.—Under the provisions of section 59J. of the Forest Department Code, examination leave for two months is granted to Mr. P. W. Healy, Extra Assistant Conservator of Forests, with effect from the 27th August, 1892, or the subsequent date on which he may have availed himself of it.

2nd September, 1892.—No. 8.—With reference to Revenue Department Notification No. 226 (Forests), dated Rangoon, the 4th August, 1892, Mr. R. F. Lewis, Extra Assistant Conservator of Forests, relinquished charge of the Ruby Mines sub-division on the afternoon of the 8th August, 1892 and joined the Pyinmana division on the afternoon of the 11th August, 1892.

12th September, 1892.—No. 271 (*Erratum*).—In this department Notification No. 235, dated the 9th August, 1892, granting an extension of leave to Maung Shwæ Ka, Extra Assistant Conservator of Forests, for "twenty-five days" read "twenty-six days."

12th September, 1892.—No. 6.—With reference to Revenue Department Notification No. 225, dated Rangoon, the 4th August, 1892, Mr. C. W. A. Bruce, Assistant Conservator of Forests, made over,

and Mr. A. M. Burn-Murdoch, Assistant Conservator of Forests, received charge of, the Minbu division on the afternoon of the 4th instant.

16th September, 1892.—No. 279.—Mr. H. B. Anthony, who has been appointed to be a Deputy Conservator of Forests in Burma, reported his arrival in Rangoon on the 16th September, before noon, and is posted to the charge of the Toungoo forest division. Mr. Anthony will rank next after Mr. John Copeland in the 4th grade of Deputy Conservators.

19th September, 1892.—No. 280.—Mr. F. J. Branthwaite, Assistant Conservator of Forests, is transferred from Toungoo to the Pegu sub-division of the Rangoon division.

14th September, 1892.—No. 2.—Mr. P. W. Healy, Extra Assistant Conservator of Forests made over, and Mr. T. A. Hauxwell, Deputy Conservator of Forests, received, charge of the Agency division on the afternoon of the 5th September, 1892.

22nd September, 1892.—No. 304.—In the exercise of the power conferred by section 35 (a) of the Burma Forest Act, 1881, and in supercession of the Notifications in the Revenue Department cited in the margin, the Chief Commissioner declares that from the date of this Notification the undermentioned

trees standing on any land at the disposal of Government shall be reserved trees within the local limits hereinafter named :—

Thitka	}	In the whole of Lower Burma.
Thickado		
Thingan		
Kanyin		
Cutch		

Kaunghmu	}	In the whole of Lower Burma except the districts of Padauk the Arakan Commissionership.
Padauk		

Pyinma or lezani or kamaung.—In the whole of Lower Burma except the districts of Tavoy, Mergui.

Pyinkado.—In the districts of the Arakan Commissionership.

Kadut.—In the districts of Amherst, Tavoy, Mergui, and the Salween Hill Tracts, and so much of the district of Shwegyin as is in the Tenasserim forest circle.

Magale	}	In the districts of Tavoy and Mergui.
Karawe		
Anan		
Kanzaw		

9.—ASSAM GAZETTE.

7th September, 1892.—No. 8124G.—With effect from the 16th May, 1892, Mr. H. G. Young Deputy Conservator of Forests, Fourth Grade, is promoted to be substantive Deputy Conservator, Third Grade *vice* Mr. D. P. Copeland, promoted.

15th September, 1892.—No. 8379G.—Privilege leave of absence for six weeks, under article 291 of the Civil Service Regulations, is granted to Babu Jogesvar Sur, Extra Assistant Conservator of Forests, in charge of the Garo Hills Forest Division, with effect from the date on which he may avail himself of it.

15th September, 1892.—No. 8380G.—Mr. T. J. Campbell, Deputy Conservator of Forests, Goalpara, is placed in charge of the Garo Hills Forest Division during the absence on privilege leave of Babu Jogesvar Sur, or until further orders, with effect from the date of receiving charge.

10.—HYDERABAD RESIDENCY GAZETTE.

24th August, 1892.—No. 256.—Mr. L. R. Martin is appointed Probationary Extra Assistant Conservator of Forests in Berar on Rs. 100 per mensem with effect from the 24th July, 1892.

Mr. Martin reported his arrival in Amraoti on the afternoon of the 23rd July, 1892, and is posted for duty in the Ellichpur Division under the orders of the Divisional Forest Officer, Ellichpur.

Lac.

BURMA. As already stated, the vast forests of Burma are capable of producing an almost unlimited quantity of lac. The chief sources of Commercial Burmese lac are the Shan States and Upper Burma, "stick-lac" from these places being imported in considerable quantity into Calcutta, where it is re-manufactured into "shell-lac" for export.

PODOPHYLLUM EMODI.

Mr. Hooper, Quinologist to the Government of Madras, writes:—"I was very pleased to see the *Indian Forester* has commenced the series of articles on Forest Products, and am interested to find that the first article deals with *Podophyllum emodu*. It has been analysed in America, and the resin has been found to be superior to the resin of *P. peltatum*.

Analysis of resin of *Podophyllum emodi* by F. A. Thompson.

Ash	None.
Moisture	... 4.2
Oily and waxy matter soluble in benzine	... 4.0
Podophyllotoxin acid	... 13.1
Podophyllotoxin (active principle)	... 56.55
Inert matter insoluble in chloroform, and soluble in Alcohol	... 22.15
	100.00

The percentage of active principle, podophyllotoxin, in this sample is fully 25 per cent. higher than the average amount found in resin of *Podophyllum*, which varies from 40 to 45 per cent. American *Podophyllum* yields, on a large manufacturing scale, 5 per cent. of podophyllin, and, accepting 10 per cent. as the practical average from the Indian, we should have a drug worth $2\frac{1}{2}$ times in value. (*Am. Journ. Pharmacy.*)

"EAST INDIAN WALNUT."

(ALBIZZIA LEBBEK.)

The attention of Conservators of Forests and others is drawn to the fact that specimens of this widely distributed timber, to which the name "East Indian Walnut" has been given by the home trade, have been occasionally forwarded to London from the Andamans in the form of planks. The timber, when well grained, finds a ready market, selling equally well with Padauk. The Deputy Conservator of Forests, Port Blair, reports that it makes pretty furniture and works up well when carved in the Burmese style. Unfortunately the supply in the Andamans is very limited, or the timber would have been exported to London in greater quantity.

The possibility of creating a regular export trade from India in this timber appears to be well worthy of the consideration of the Forest Department as well as of Timber Merchants in India, and it is hoped that further information on the subject will be forthcoming in the pages of the *Indian Forester*.

PADAUK.

(PTEROCARPUS INDICUS.)

With reference to the article on Padauk published in the *Indian Forester* July, 1892, Appendix series, it may be mentioned that this wood has been favourably received in America. Specimens worked up as furniture and as wall-dados can be seen at the London Offices of Messrs. Ogilvy, Gillanders and Co.

EDGAR THURSTON.

INDIAN MUSEUM,
Calcutta.

LAC.

A correspondent writing from Mirzapur on behalf of a Shell-lac Factory, has asked for information as to the Lac Crop. "There are," he says, "four crops during the year. We are one of the largest buyers of lac during the year, and should be obliged if you would supply me with the statistics of the out-turn of crops from a one anna crop to a sixteen anna or full crop. This year the April-May crop was very short. We would like to know about the prospects of the coming October-November crop."

I shall be very much obliged if Forest Officers and others interested in the subject will send me any information which they may have or may be able to collect, especially with reference to lac-producing areas which are not as yet received, but any information not already contained in the Dictionary of Economic Products, from which the following extract, condensed from Mr. O'Connor's note on Lac (1876), is taken, will be very acceptable.

BENGAL AND ASSAM. In Bengal, lac is produced abundantly in the Jungle tracts of Birbhum, Chutia Nagpur, and Orissa. In various places in the Forests of Assam, it is also found in large quantities and forms a regular article of trade, a portion of the production being manufactured at Dacca, and the rest sent to Calcutta. In 1867, the Deputy Commissioner of Purulia in Chutia Nagpur, reported that the smallest average yearly supply from the district was 15,000 maunds, though the actual yield was, he believed, considerably more, while it was capable of great extension. From Singhbhum, at the same period, about 1,250 maunds of lac were exported annually. In the Gya district the supply was estimated at 12,000 maunds; in Kamrup (Assam) about 5,000 maunds, with great capacity for development; in Hazaribagh at 2,000 maunds. Mr. O'Connor, however, remarks that these figures probably do not by any means approximate to the actual yield of the districts named.

In Bengal, lac is gathered twice a year, *viz.*, from about the middle of October to the end of January, and from the middle of May to the middle of July.

THE NORTH-WEST PROVINCES. Lac is obtained in some quantities from the Garhwal forests, and is said to have been largely exported to the plains some years ago. Mr. O'Connor, however, considers it probable that most of the substance thus brought down from Garhwal is consumed in the Provinces, very little, if any, being sent to Calcutta.

ODISHA. Lac is gathered in the more wooded parts of the South-Eastern districts, and is exported to the Mirzapore factories and elsewhere.

THE PUNJAB. Baden-Powell states that the production of lac is universal in this Province. According to Mr. O'Connor, however, Punjab lac is inferior in quality, and is probably not exported, the whole production being consumed locally.

SIND. Lac is, in Sind, found only in the forests about Hyderabad, 12 miles North and South of the town. It occurs on *Acacia Arabica*, a tree which, in moister regions, appears to be exempt from the attacks of the insect. The substance thus obtained is largely used in the manufacture of the well-known lacquered-ware of Hyderabad.

CENTRAL PROVINCES. Large quantities of lac are found in all the districts of these Provinces, but particularly in the more Eastern parts. It has been stated that the Central Provinces could readily supply some 25,000 tons of stick-lac annually. A considerable amount is consumed locally for the manufacture of bracelets and other articles, but most districts also export to a greater or less extent. The incrustation is collected by jungle-tribes, Bahelyas, Rajhors, Bhirrijas, Kurkus, Dhanuks, Nahils, Bhois, and some classes of Muhammadans, who sell the produce in small quantities to Patwas, who again retail it in larger quantities to the regular dealers.

MYSORE. In this Province lac is produced in all three districts, but chiefly in Nundidrug. It is, however, not known how much might be procurable annually, the produce being collected in many places by several petty contractors, but the supply is certainly large, and probably capable of increase. At present nearly the whole production appears to be consumed locally, since the exports from Madras and Mysore are very small.

VIII.—EXTRACTS FROM OFFICIAL GAZETTES.

1.—GAZETTE OF INDIA.

21st October, 1892.—No. 1307-F.—With reference to the Notification of this Department, No. 293-F., dated 27th February 1891, an extension of furlough for two months has been granted by Her Majesty's Secretary of State to Mr. H. C. Hill, Conservator of Forests, 1st Grade.

2.—MADRAS GAZETTE.

21st September, 1892.—Forester First-grade C. Dhan Sing to act as Ranger, Fifth Grade, sub. *pro tem.*, with effect from 1st September 1892.

29th September 1892.—Leave to Ranger M. Shumsudden Sahib for two months, from 8th September 1892, under article 369 of the Civil Service Regulations.

29th September 1892.—Mr. G. W. Thompson, Ranger, Fifth Grade, to act in the Fourth Grade during Ranger Shumsudden's absence on leave.

3rd October 1892,—No. 468.—In the schedule appended to the notification under section 63 (a) of Act V of 1882, published at pages 588 and 617 of Part I of the *Fort St. George Gazette*, dated 23rd September and 7th October 1884, respectively, the term "Extra-Assistant" should be inserted before the words "or Sub-Assistant Conservator."

4th October 1892.—In supersession of the sick leave granted to Ranger Mr. Bower and notified at page 1224, Part II of the *Fort St. George Gazette*, dated 6th September 1892, that officer is granted privilege leave, under article 291 of the Civil Service Regulations, for twenty-two days from 25th August 1892.

6th October 1892.—Ranger M. L. Naraina Sastri from South Arcot to the Cuddapah District, to join at once.

Ranger M. Kothandarama Mudaliar from the Cuddapah to the Salem District.

Ranger C. N. Lakshman Row from the Salem to the South Arcot District.

11th October 1892.—No. No. 477.—Mr. R. McIntosh, Acting District Forest Officer, Cuddapah, is granted examination leave for two months.

18th October 1892.—No. 492.—Mr. F. D. M. Hooper, Acting Conservator of Forests, Northern Circle, is granted furlough for one year and six months, under article 340 (a) of the Civil Service Regulations.

18th October, 1892.—To Ranger M. Kothandarama Mudaliar privilege leave for one month from date of relief, under article 291 of the Civil Service Regulations.

16th October 1892.—To Ranger C. N. Lakshman Row privilege leave for two months from date of relief under article 269 of the Civil Service Regulations.

3.—BOMBAY GAZETTE.

7th October, 1892.—No. 7956.—His Excellency the Governor in Council is pleased to appoint Mr. G. K. Betham to act as Divisional Forest Officer, South Kanara.

12th October, 1892.—No. 8102.—Mr. A. C. Robinson, South Sub-Division Forest Officer, North Thana, passed an examination in Marathi on the 7th October, 1892.

14th October 1892.—No. 8155.—In exercise of the power conferred by Section 70 of the Indian Forest Act, No. VII of 1878, the Governor in Council is pleased to direct that, in lieu of the fines fixed

* Name of Kuran.	Name of village near which situated.
1. Sussawadi ...	1. Sussawadi. 2. Kolhar.
2. Kapurwadi ...	3. Pimpalgaon Ujani. 1. Kapurwadi. 2. Deogaon.
3. Shendi ...	1. Shendi. 2. Dangarwadi.
4. Manjarsumba ...	1. Pimpalgaon Malwi. 2. Manjarsumba. 3. Dehera.
5. Ghospuri ...	1. Gutawaree. 2. Ghospuri.

by Section 12 of the Cattle-trespass Act 1871 there shall be levied in the Nagar Taluka of the Ahmednagar District, on and after the 15th August 1892, in respect of cattle trespassing in the closed portions of the Reserved Forest Kurans mentioned in the margin,* and impounded under Section 69 of the Indian Forest Act, fines at the

following rates, viz. :—

For each buffalo	One Rupee
For each horse, mare, gelding, pony, colt, filly, bull, bullock, cow or heifer	Eight annas.
For each calf, ass, pig, ram, ewe, sheep, lamb, goat or kid	Four annas.

No. 8155A.—His Excellency the Governor in Council is pleased, under Section 2 of the Indian Forest Act, No. VII of 1878, as amended by Act No. V of 1890, to appoint the officer for the time being holding the post of Executive Commissariat Officer, Ahmednagar, to be a Forest Officer, and, under Section 75 of the same Act, is pleased to appoint the said officer to do all acts and exercise all powers that are prescribed

* Name of Kuran.	Name of village near which situated.
1. Sussawadi ...	1. Sussawadi 2. Kolhar.
2. Kapurwadi ...	3. Pimpalgaon Ujani. 1. Kapurwadi. 2. Deogaon.
3. Shendi ...	1. Shendi. 2. Dangarwadi
4. Manjarsumba ...	1. Pimpalgaon Malwi. 2. Manjarsumba. 3. Dehera.
5. Ghospuri ..	1. Gutawari. 2. Ghospuri.

by the Act or by rules made under it to be done by a Forest Officer or by any Forest Officer: such powers to be exercised in respect of the Reserved Forest Kurans in the Nagar Taluka of the Ahmednagar District specified on the margin*, which have been assigned for the use of the Commissariat Department.

4.—BENGAL GAZETTE.

1st October, 1892.—No. 3558.—In the list of revenue stations of the Sundarban Forest Division published in the notification, dated the 5th November, 1888, for “14, Cobaduk, left bank of Cobaduk river above its junction with Golputtoo river,” read “14, Cobaduk, junction of the Golputtoo and Arpangassia rivers.”

5.—N. W. P. & OUDH GAZETTE.

5th October, 1892.—No. 4622.—Mr. B. B. Osmaston, Assistant Conservator of Forests, on return from furlough, to the Direction Division of the Oudh Circle as Working Plans Officer.

No. 4625.—Mr. F. Beadon-Bryant, Deputy Conservator of Forests, on return from furlough, to the Direction Division of the Central Circle as Working Plans Officer.

5th October, 1892.—No. 4628.—Mr. W. Shakespear, Deputy Conservator of Forests, from the Pilibhit to the Ganges Division.

No. 4631.—Pandit Keshava Nand, Extra Assistant Conservator of Forests, Kheri Division, to the charge of the Pilibhit Division.

6.—PUNJAB GAZETTE,

17th October, 1892.—No. 468.—In Punjab Government Notifications Nos. 379 and 380, dated the 20 August 1892, Serial No. 20, in both lists and in the last columns, Mr. J. L. Pigot should be shown as “*Officiating Deputy Conservator of Forests, 3rd Grade*, seconded, on deputation” with effect from the 29th December 1891.

22nd October 1892.—No. 474.—*Notification*.—Mr. A. V. Monro, Assistant Conservator of Forests, on return from privilege leave, resumed charge of the Mooltan Forest Division on the forenoon of the 30th September 1892, relieving Babu Ladha Singh, Extra Assistant Conservator of Forests.

7.—CENTRAL PROVINCES GAZETTE.

28th September, 1892.—No. 3596.—Privilege leave for ninety days under Articles 277 and 291 of the Civil Service Regulations, is granted to Mr. P. H. Clutterbuck, Assistant Conservator of Forests, Raipur, with effect from the 8th September, 1892, or the subsequent date on which he may avail himself of it.

5th October, 1892.—No. 3711.—With reference to Government of India, Revenue and Agricultural Department, Notification No. 1037. F., dated the 12th August, 1892.

Mr. H. A. Hoghton, Deputy Conservator of Forests, reported his arrival at Nagpur on the forenoon of the 23rd August, 1892.

Mr. Hoghton is posted to the Seoni Forest Division.

On being relieved by Mr. Hoghton, Mr. V. S. Menzies, Assistant Conservator of Forests, Seoni Forest Division, will revert to the charge of the Nagpur-Wardha Forest Division.

No. 3712.—With reference to Notification No. 3711, dated the 5th October, 1892, Messrs. V. S. Menzies, Assistant Conservator of Forests,

and H. A. Houghton, Deputy Conservator of Forests, respectively surrendered and received charge of the Seoni Forest Division on the afternoon of the 31st August, 1891.

No. 3713.—With reference to Notification No. 3711, dated the 5th October, 1892. Messrs. H. S. K. Edie and V. S. Menzies, Assistant Conservators of Forests, respectively surrendered and received charge of the Nagpur-Wardha Forest Division the afternoon of the 5th September, 1892.

No 3714.—With reference to Notification No. 2617, dated the 26th July, 1892, Mr. Ramchandra Krishna, Extra-Assistant Conservator of Forests relinquished charge of his duties in the Chanda Forest Division on the afternoon of the 16th August 1892.

No. 3715.—Khan Sahib Munshi Mahomed Ghouse availed himself on the afternoon of the 27th August, 1892, of the leave granted him by Notification No. 2618, dated the 26th July, 1822, making over charge of the Balaghat Forest Division to Mr. Ramchandra Krishna, Extra-Assistant Conservator of Forests.

No. 3929.—Under the provisions of Government of India, Revenue and Agricultural Department, Circular No. 18-F., dated the 29th July, 1891, the following changes in the position and designation of the officers of the Lower controlling staff of the Forest service in the Central Provinces, Berar and Coorg, shall have effect from the 26th February, 1891 :—

NAME.	FROM.	To.
Mr. Chander Kumar Chatterji.	Sub-Assistant Conservator of Forests, 1st grade.	Extra-Assistant Conservator of Forests, 1st grade.
Khan Sahib Mahomed Ghouse ...	Do. do. ...	Do. do.
Mr. Mansukh Rai ...	Do. do. ...	Do. do.
Mr. Shridhar Ganesh Paranjpe ...	Do. 2nd grade ...	Do. 2nd grade.
Mr. Norman Chester McLeod ...	Do. do. ...	Do. do.
Mr. J. J. Hobday ...	Do. 3rd grade ...	Do. do.
Mr. C. H. Haldane ...	Do. 2nd grade ...	Do. 3rd grade.
Mr. Ahmed Ali ...	Do. do. ...	Do. do.
Mr. Rasul Khan ...	Do. do. ...	Do. 4th grade.
Mr. Bukhan ...	Officiating do. 3rd grade.	Officiating do.
Mr. Ramchandra Krishna	Do. do. ...	Do. do.
Mr. R. C. Thompson.	Do. do. no probation.	Do. do. on probation.

No. 3930.—Mr. Mahomed Kadar Buksh, Sub-Assistant Conservator of Forests, 3rd grade, sub. *pro tem.*, is appointed Extra-Assistant Conservator of Forests, 4th grade, sub. *pro tem.*, with effect from the 4th March, 1891.

No. 3931.—Mr. Shrinivasullu Naidu, Sub-Assistant Conservator of Forests, 3rd grade, on probation, is appointed Extra-Assistant Conservator of Forests, 4th grade, on probation, with effect from the 5th May, 1891.

No. 3932.—Mr. Ramchandra Krishna, Officiating Extra-Assistant Conservator of Forests, 4th grade, is appointed Extra-Assistant Conservator of Forests, 4th grade, sub. *pro tem.*, with effect from the 1st June, 1891.

No. 3933.—The following officers are confirmed in the 4th grade of Extra-Assistant Conservators of Forests, with effect from the 1st October, 1891 :—

Mr. Ramchandra Krishna, Extra-Assistant Conservator of Forests, 4th grade, sub. *pro tem.*

Mr. Mahomed Kadar Buksh, Extra-Assistant Conservator of Forests 4th grade, sub. *pro tem.*

Mr. Bukhan, Officiating Extra-Assistant Conservator of Forests, 4th grade.

No. 3934.—The following Extra-Assistant Conservators of Forests of the 4th grade are promoted to the 3rd grade, with effect from the 1st April, 1892 :—

Mr. Ramchandra Krishna.

Mr. Mahomed Kadar Buksh.

No. 3935.—Mr. R. C. Thompson, Extra-Assistant Conservator of Forests, 4th grade, on probation, is appointed Extra-Assistant Conservator of Forests of the 4th grade, sub. *pro tem.*, with effect from the 1st April, 1892.

No. 3936.—Mr. Shrinivasulu Naidu, Extra-Assistant Conservator of Forests, on probation, is appointed Extra-Assistant Conservator of Forests, 4th grade, with effect from the 1st April, 1892.

No. 3937 :—Mr. L. K. Martin is appointed as Extra-Assistant Conservator of Forests, 4th grade, on probation, with effect from the 24th July, 1892.

No. 3938.—Mr. F. Seager is appointed as Extra-Assistant Conservator of Forests, 4th grade, with effect from the 24th August, 1892.

No. 3939.—The position of the officers of the Lower controlling staff of the Forest service in the Central Provinces, Berar and Coorg, stood as follows on the 25th August, 1892 :—

NAME.	APPOINTMENT.	REMARKS.
Mr. Chander Kumar Chatterji.	Extra-Assistant Conservator of Forests, 1st grade.	
Khan Sahib Mahomed Ghouse ...	Do. do.	
Mr. Mausukh Rai ...	Do. do.	
Mr. Shridhar Ganesh Pranipe ...	Do. 2nd grade.	
Mr. Norman Chester McLeod ...	Do. do.	
Mr. J. J. Hobday ...	Do. do.	
Mr. C. H. Haldane ...	Do. 3rd grade.	
Mr. Ahmed Ali ...	Do. do.	
Mr. Ramchandra Krishna ...	Do. do.	
Mr. Mahomed Kadar Buksh ...	Do. do.	
Mr. Rasul Khan ...	Do. 4th grade.	
Mr. Bukhan ...	Do. do.	
Mr. R. C. Thompson ...	Do. do.	Supernumerary.
Mr. Shrinivasulu Naidu ...	Do. do.	
Mr. F. Seager ...	Do. do.	
Mr. L. K. Martin ...	Do. do.	On probation.

The 19th October.—1892.—No. 3945.—Mr. P. H. Clutterbuck, Assistant Conservator of Forests, availed himself, on the forenoon of the 6th instant, of the privilege leave granted him by Notification No. 3596, dated the 28th September, 1892, making over charge of the Raipur Division to Colonel W. S. Brooke, Deputy Commissioner.

8.—BURMA GAZETTE.

21st September, 1891.—No. 7.—With reference to Revenue Department Notification No. 105 dated Rangoon, the 16th June 1892, Mr. H. R. Thompson, Assistant Conservator of Forests, made over, and Mr. H. H. Fortheath, Assistant Conservator of Forests, received, charge of the Upper Chindwin division on the afternoon of the 1st instant.

21st September, 1892.—No. 17.—With reference to Revenue Department Notification No. 279, dated Rangoon, the 16th September, 1892, Mr. F. J. Branthwaite, Officiating Deputy Conservator of Forests, received charge of the Toungoo division on the forenoon of the 20th September, 1892.

29th September, 1892.—No. 315.—Under the provisions of Article 291 of the Civil Service Regulations, privilege leave for 85 days is granted to Mr. W. A. Hearsey, Extra Assistant Conservator of Forests, with effect from the 1st October, 1892, or the subsequent date on which he may avail himself of it.

9th October, 1892.—No. 324.—The following alterations of rank are ordered in the Forest Department :—

- (1) With effect from the 10th June, 1892 :—
Mr. C. R. Dun, Assistant Conservator of Forests, 2nd grade, to officiate as Assistant Conservator, 1st grade.
- (2) With effect from the 9th July, consequent on the departure of Mr. E. A. O'Bryen on privilege leave :
Mr. C. R. Dun, Assistant Conservator, 2nd (officiating 1st) grade, to officiate as Deputy Conservator, 4th grade.
- (3) With effect from the 20th July, 1892, consequent on the departure of Mr. C. H. Hobart-Hampden on privilege leave :
Mr. C. E. Muriel, Deputy Conservator, 4th (officiating 3rd, to officiate as Deputy Conservator, 2nd grade.
Mr. C. L. Toussaint, Assistant Conservator, 1st grade, officiating Deputy Conservator, 4th grade, to officiate as Deputy Conservator, 3rd grade.
- (4) With effect from the 2nd August, 1892, consequent on the return of Mr. H. B. Ward from privilege leave :
Mr. C. E. Muriel, Deputy Conservator, 4th (officiating 2nd) grade, to officiate as Deputy Conservator, 3rd grade.
Mr. C. L. Toussaint, Assistant Conservator, 1st grade, officiating Deputy Conservator, 3rd grade, to officiate as Deputy Conservator, 4th grade.
- (5) With effect from the 10th August, 1892, consequent on the departure of Mr. F. W. Thellusson on furlough :
Mr. T. A. Hauxwell, Deputy Conservator, 3rd (officiating 2nd) grade, to officiate as Deputy Conservator, 1st grade.
Mr. C. E. Muriel, Deputy Conservator, 4th (officiating 3rd) grade, to officiate as Deputy Conservator, 2nd grade.

Mr. C. L. Toussaint, Assistant Conservator, 1st grade officiating Deputy Conservator, 4th grade, to officiate as Deputy Conservator, 3rd grade.

- (6) With effect from the 17th August, 1892, consequent on the transfer of Mr. H. A. Houghton to the Central Provinces, and pending the arrival of Mr. H. B. Anthony :

Mr. G. Q. Corbett, Deputy Conservator, 4th (officiating 3rd) grade, to officiate as Deputy Conservator, 2nd grade.

Mr. F. J. Branthwaite, Assistant Conservator, 1st, officiating Deputy Conservator, 4th grade, to officiate as Deputy Conservator 3rd grade.

- (7) With effect from the 16th September, 1892, consequent on the transfer of Mr. H. B. Anthony to Burma :

Mr. H. B. Anthony, Deputy Conservator, 4th grade, to officiate as Deputy Conservator, 2nd grade.

Mr. G. Q. Corbett, Deputy Conservator, 4th (officiating 2nd) grade, to officiate as Deputy Conservator, 3rd grade.

Mr. F. J. Branthwaite, Assistant Conservator, 1st, officiating Deputy Conservator, 3rd grade, to officiate as Deputy Conservator, 4th grade.

13th October, 1892.—No. 325.—The following postings and transfers are ordered in the Forest Department :—

Mr. C. W. Palmer, Deputy Conservator of Forests, on his return from leave, to the charge of the Minbu Forest division.

Mr. C. W. A. Bruce, officiating Deputy Conservator of Forests on his return from leave, to the charge of the Upper Chindwin Forest division.

Mr. H. H. Forteath, Assistant Conservator of Forests, to the headquarters of the Upper Chindwin Forest division.

Mr. A. M. Burn-Murdoch, Assistant Conservator of Forests, from Minbu to the charge of the Magwe sub-division of the Minbu Forest division.

3rd October, 1892.—No. 18.—With reference to Government of India, Revenue and Agricultural Department Notification No. 1037F., dated the 12th August, 1892, Mr. H. A. Houghton, Deputy Conservator of forests, made over charge of his duties in this office on the afternoon of the 16th August, 1892.

8th October, 1892.—No. 19.—With reference to Revenue Department Notification No. 252F., dated the 27th August, 1892, Mr. E. B. Powell, Extra Assistant Conservator of Forests, made over charge of the Myanaung sub-division on the forenoon of the 12th instant and assumed charge of his duties in the Tharrawaddy division on the afternoon of the 16th instant.

No.—With reference to Revenue Department Notification No. 280 F., dated the 10th September, 1892, Mr. F. J. Branthwaite, officiating Deputy Conservator of Forests, assumed charge of the Pegu sub-division on the afternoon of the 28th ultimo.

13th October, 1892.—No. 9.—Mr. W. A. Hearsey, Extra Assistant Conservator of Forests, availed himself of the privilege leave granted to him in Revenue Department Notification No. 315 (Forests), dated Rangoon, the 29th September, 1892, on the forenoon of the 3rd October, 1892.

14th October 1892,—No. 326.—(CORRIGENDUM).—In the heading to the form prescribed in Revenue Department Notification No. 98, dated the 17th March, 1892, for “VII A” read “VII B.”

No. 327.—In exercise of the power conferred by section 37 of the Burma Forest Act, 1881, and in supersession of the notifications superseded thereby, the Chief Commissioner prescribes the following rules to regulate the matters referred to in clauses (c), (d), (g), and (h) of the said section :—

8. No person shall cut, saw, convert, or remove any tree other than a reserved tree on any land at the disposal of Government, not included in a reserved forest or village forest, or the timber of any such tree, unless either—

- (a) such tree or timber is cut, sawn, converted, or removed for the building of bridges, rest-houses, or other works of public utility ; or
- (b) such tree or timber is cut, sawn, converted, or removed for use within the revenue circle wherein, or within 5 miles of the place in which such tree or timber is produced for *bona fide* agricultural, fishery, or domestic purposes ; or
- (c) such tree or timber is cut, sawn, converted, or removed for immediate conversion into firewood within the limits of the forest in which it is cut and before passing the station at which revenue would be ordinarily payable ; or
- (d) such tree or timber is cut, sawn, converted, or removed for the purposes of burning charcoal by a person possessing a license in Form VIII ; or
- (e) such timber is cut, sawn, converted, or removed under and subject to the conditions of a license granted by the Deputy Commissioner, or Forest Officer of the district, or by any officer empowered by the Deputy Commissioner in that behalf in one or other of the Forms Nos. VI, VIA, VII, VIIA, VIIB, IXA, and IXB given in the Appendix to these rules.

Provided, however, that—

(1) No one shall cut, fell, or lop *than* trees on any such land for the purpose of manufacturing *thansha* or collect or remove *than* timber for such purpose.

(2) No person shall cut trees within two chains of the bank of any stream to which the Deputy Commissioner of the district in which the stream is situated may by public notice declare this rule to apply. The notices published under this rule shall specify the points on the stream referred to between which the cutting of trees is prohibited, and shall be served on the headmen of all villiages near and posted up at convenient places in such villiages and along the stream. The Deputy Commissioner may cancel or vary by publication in similar manner any notices issued under this rule.

(3) On all firewood brought to Rangoon there shall be levied the following fees :—

	Rs.	A.	P.
On fire wood not exceeding 6 feet in length and 2 feet in girth, per 1,000 billets	10	0	0
On firewood not exceeding 4 feet 6 inches in length and 2 feet in girth, per 1,000 billets	8	0	0
On firewood not exceeding 4 feet 6 inches in length and 1 foot in girth, per 1,000 billets	2	8	0
On firewood not exceeding 3 feet in length and 1 foot in girth, per 1,000 billets	1	0	0
On firewood small, in bundles of 10, not exceeding 1 foot in length, per 1,000 bundles	1	0	0

The above fees shall be paid at one or other of the collecting stations at Alón, Pazundaung, Botataung, Williams street wharf, or Sinmaleik, and no firewood shall be removed until the fees payable in respect thereof have been paid.

9. No person shall collect or remove wood-oil or resin, the natural produce of any land at the disposal of Government, not included in a reserved or village forest, except under and in accordance with the conditions of a license granted by the Deputy Commissioner, or Forest Officer of the district, or by an officer empowered by the Deputy Commissioner in that behalf, in one or other of the Forms X and XI, given in the Appendix to these rules.

a. No person shall burn charcoal on any land at the disposal of Government and not included in a reserved or village forest, except under and in accordance with the conditions of a license granted by the Deputy Commissioner or the Forest Officer of the district, or by any officer empowered by the Deputy Commissioner in that behalf, in Form VIII given in the Appendix to these rules.

9b. No person shall make use of the natural produce of any land at the disposal of Government and not included in a reserved or village forest other than natural produce of the kinds referred to in Rules 8 to 9a, except under and in accordance with a license granted by the Deputy Commissioner or the Forest Officer of the division or by any officer empowered by the Deputy Commissioner in that behalf for such time and on such conditions as the said Deputy Commissioner or Forest Officer may prescribe.

Provided that in any district in which the Deputy Commissioner deems it unadvisable to issue licenses for the making use of any particular kind of natural produce to which this rule applies, the Deputy Commissioner or the Forest Officer of the division may sell by public auction annually, to the highest bidder, the right to collect such produce in any defined or demarcated tract.

10. Any person infringing Rule 5, or Rule 8, or Rule 9, or Rule 9a, or Rule 9b, shall be punishable with imprisonment for a term which may extend to six months, or with fine which may extend to Rs. 500, or with both.

No. 328.—With reference to the foregoing notification, the Chief Commissioner directs that so much of clause (e) of Rule 8 as prescribes Forms VIA and VIIA shall not come into force till the 1st January, 1893.

No. 329.—In exercise of the power prescribed by section 87 of the Burma Forest Act, 1881, the Chief Commissioner directs that the figure and letter "9a" shall be substituted for the figure "8" in the form prescribed in Revenue Department Notification No. 267, dated the 17th November 1891.

No. 333.—In exercise of the power conferred by section 46 of the Burma Forest Act, 1881 the Chief Commissioner directs that in Revenue Department Notification No. 75 dated the 30th May 1890, the following words, namely.

"Clauses (a) to (d) of Rule 8 of the rules published in Revenue Department Notification No. 327, dated the 14th October, 1892,"

shall be substituted for the words—

"Clauses (a) to (c) of sub-head (1), Rule 8 of the rules published under this Department Notification No 11 (Forests) dated the 10th January 1883, as revised by this Department Notification No. 108 (Forests), dated the 1st August, 1889."

No. 331.—In exercise of the power conferred by section 43 of the Burma Forest Act, 1881, the Chief Commissioner makes the following amendments in Rules 12 and 23 of the Lower Burma Forest Rules published in Revenue Department Notification No. 15, dated the 23rd January, 1892, and No. 76, dated the 30th May 1890 :—

1. In proviso (b) of Rule 12 for "Rule 8 (b)" read "Rule 8 (b) and (d)."

2. In Rule 23, clause (a), for "Rule 8, sub-head (1), clauses (a) and (b)," read "Rule 8, clauses (a) and (b)."

No. 332.—In exercise of the power conferred by section 40 of the Burma Land and Revenue Act, 1876, and with the previous sanction of the Governor-General in Council, the Chief Commissioner makes the following rules to provide for the disposal of certain kinds of forest produce. These rules supersede Rules 121, 122, and 123 of the rules published in Revenue Department Notification No. 151, dated the 4th September 1890 :—

121. No person shall prepare or collect any produce of the kinds referred to in the abovementioned section, other than produce of the kinds referred to in Rules 8, 9, and 9a of the rules under the Burma Forest Act, 1881, published in Revenue Department Notification No. 327, dated the 14th October, 1892, except under and in accordance with, a license granted by the Deputy Commissioner, or the Forest Officer of the division, or by any officer empowered by the Deputy Commissioner in that behalf, for such time and on such conditions as the said Deputy Commissioner or Forest Officer may prescribe.

Provided that in any district in which the Deputy Commissioner deems it inadvisable to issue licenses for the making use of any particular kind of produce to which this rule applies, the Deputy Commissioner or the Forest Officer of the division may sell by public auction annually to the highest bidder the right to collect such produce in any defined or demarcated tract.

122 Any person who shall prepare or collect any produce of the kinds mentioned in Rule 121 without having acquired the right to do so in the manner provided in Rule 121 may, in addition to any other consequences to which may be liable, be punished on conviction before

a Magistrate with rigorous or simple imprisonment for a term not exceeding one month, or with a fine not exceeding Rs. 100, or with both.

17th October.—No. 333.—Mr. W. T. T. McHarg, Assistant Conservator of Forests, is transferred from Katha to the Mandalay Forest division.

No. 334 (CORRIGENDUM).—In this department Notification No. 295 dated the 20th September 1892, for "Nyaungbin" read "Nyaunglun" in the two places where the former word occurs.

20th October, 1892.—No. 349.—Mr. A. L. Home, Conservator of Forests, on his return from furlough, is posted to the charge of the Western Forest Circle, Upper Burma.

No. 350.—Mr. T. H. Aplin, Officiating Conservator of Forests, Western Circle, Upper Burma, on being relieved by Mr. A. L. Home, is posted to the charge of the Lower Chindwin Forest division.

No. 351.—Mr. H. N. Thompson, Assistant Conservator of Forests, on being relieved of the charge of the Lower Chindwin division, is appointed to do duty as subdivisinal Officer in the Lower Chindwin division.

No. 352.—Under the provisions of section 43, clause (g) of the Burma Forest Act, 1881, the Chief Commissioner is pleased to add the following place to the list of stations to which timber or other forest produce in transit shall be taken by those in charge of it for examination or for the realization of any money payable to Government in respect thereof, or in order that any mark may be affixed thereto :—

Pegu Forest Circle.

Thayetmyo division,—Minhla:

20th October, 1892.—No. 358.—In exercise of the power conferred by section 40 (2) (g) of the Upper Burma Forest Regulation, 1887, and in supersession of previous notifications, the Chief Commissioner adds the following rule to the rules under the Upper Burma Forest Regulation :—

32 (a) The undermentioned places are established as revenue stations to which forest produce shall be taken by the person in charge of it for examination, and for the realization of any money payable to Government and for the purpose of affixing marks thereto :

Eastern Forest Circle.

Division.	Revenue station.	Civil district in which station is situated.
Bhamo.	{ Bhamu Shwegu	{ Bhamo
Katha	{ Katha Dobin Kyundaung Tigyain Kyanhnyat	{ Katha.

Mandalay	}	Madaya	} Mandalay.	
		Mandalay including Nanda kyun		*Mandalay.† Sagaing.
		Ava* including Amarapura *and		
		Saging.†		
		Paleik		
		Kyaukse		
Myitha				
		The daw Railway station	} Meiktila	
		Meiktila Road Railway station ...		
Mu	}	Kyunhla	} Ye-u	
		Ye-u		
		Shwebo	} Shwebo.	
		Kyaukmyaung		
		Myinmu		Sagaing.
Pyinmana	}	Pyawbwe	} Yamethin.	
		Yamethin		
		Pyinmana	} Pyinmana.	
		Yeni		

Western Forest Circle.

Division.	Revenue Station.	Civil district in which station is situated.
Yaw	Pakókku	Pakókku.
Upper Chindwin ...	Kindat	Upper Chindwin.
Lower Chindwin ...	Alôn, Chindwin river	Lower Chindwin.
Minbu	Zigat* (including Salè)*	*Pakókku. †Myingyan.
	Mingón ^a	*Magwe.
	Mezali, Môn river ..	Minbu.

No. 359.—In exercise of the power conferred by section 40 of the Upper Burma Forest Regulation, 1887, the Chief Commissioner makes the following amendments in the rules under the said Regulation :—

Rule 15.—Omit the words “appointed by the local Government in this behalf.”

Rule 16.—Omit the words “appointed by the local Government in this behalf.”

Rule 25, clause (1).—Omit the word and figures “and 31,” and for the word “apply” read “applies.”

9.—ASSAM GAZETTE.

12th October, 1892.—No. 9131G.—Mr. J. E. Barrett, Deputy Conservator of Forests, on return from leave, is placed in charge of the Cachar Forest Division.

12th October, 1892.—No. 9132G.—Mr. G. H. Young, Deputy Conservator of Forests, Cachar Forest Division, on being relieved by Mr. J. E. Barrett, is placed in charge of the Kamrup Forest Division.

12th October, 1892.—No. 9133G.—Mr. A. M. Long, Assistant Conservator of Forests, Kamrup Forest Division, on being relieved by Mr. H. G. Young, is placed in charge of the Sibsagar Forest Division.

12th October, 1892.—No. 9184.—Mr. D. P. Copeland, Deputy Conservator of Forests, on return from privilege leave, is placed in charge of the Darrang Forest Division.

10.—HYDERABAD RESIDENCY GAZETTE.

19th September, 1892.—No. 278.—In consequence of the amalgamation of the Controlling staff of the Forest Department of the Punjab, with those of the Central Provinces, Berar and Coorg, in accordance with Government of India Circular No. 30-F., dated the 29th December, 1891, the following list is published; showing the names and position of the officers on the combined lists on the 29th December 1891 :—

Serial number in list.	Name.	Position.
Same as in Punjab Gazette, Notification No. 379 dated 20th August, 1892, <i>vide</i> September number of the <i>Indian Forester</i> .		

19th September, 1892.—No. 279.—Consequent on the appointment to the Central Provinces of Mr. H. S. K. Edie, *vide* Government of India Notification No. 532-F. dated the 6th May 1892, the amalgamated list of the Punjab, Central Provinces, Berar and Coorg, will on the 31st December 1891, stand as follows :—

Serial number in list.	Name.	Position.
Same as in Punjab Gazette, Notification No. 380 dated 20th August, 1892, in September number of the <i>Indian Forester</i> .		

19th September, 1892.—No. 280.—Consequent of the transfer to the Imperial List of Mr. A. E. Wild, on his appointment as Conservator of Forests, 3rd grade, *vide* Government of India Notification No. 526-F., dated 6th May 1892, the following promotions shall have effect from the 17th January 1892 :—

See Punjab Gazette Notification, No. 381, dated 20th August, 1892, as above.

19th September, 1892.—No. 281.—Consequent on the departure of Mr. F. S. Barker, Officiating Deputy Conservator of Forests, 3rd grade, on leave on medical certificate for 12 months, the following promotions shall have effect from the 22nd January 1892 :—

See Punjab Gazette Notification, No. 382, dated 20th August, 1892, as above.

19th September, 1892.—No. 282.—Consequent on the return from furlough of Mr. W. King, Deputy Conservator of Forests, 4th grade, the following changes shall have effect from the 8th February 1892 :—

See Punjab Gazette Notification.—No. 383 dated 20th August, 1892, as above.

19th September, 1892.—No. 283.—Consequent on the return from leave of Mr. G. S. Hart, Assistant Conservator of Forests, 1st grade, the following changes shall have effect from the 13th February 1892:—

See Punjab Gazette Notification.—No. 384 dated 20th August, 1892, as above.

19th September, 1892.—No. 284.—Consequent upon the death of Mr. A. J. Mein, Deputy Conservator of Forests, 3rd grade, the retransfer from Assam to the Punjab of Mr. A. M. Reuther, Deputy Conservator of Forests, 4th grade, and the transfer of Mr. J. L. Pigot, Deputy Conservator of Forests, 4th grade, from the Central Provinces to Assam, the following changes shall have effect from the 2nd of March 1892:—

See Punjab Gazette Notification.—No. 388 dated 20th August, 1892, as above.

19th September, 1892.—No. 285.—Consequent on the appointment of Mr. R. H. E. Thompson, Deputy Conservator of Forests, 1st grade, as Conservator of Forests, 4th grade, *vide* Government of India Notification No. 594-F., dated the 20th May 1892, the following promotions shall have effect from the 4th of April 1892:—

See Punjab Gazette Notification.—No. 386, dated 20th August, 1892, as above.

19th September, 1892.—No. 286.—Consequent on the return from deputation in the Patiala State of Mr. G. G. Minniken, Deputy Conservator of Forests, 2nd grade, the following changes shall have effect from the 5th May 1892:—

See Punjab Gazette Notification.—No. 387 dated 20th August, 1892 as above.

19th September, 1892.—No. 287.—Consequent on the departure on three months' privilege leave of Mr. H. B. Anthony, Deputy Conservator of Forests, 4th grade, the following promotion shall have effect from the 8th June 1892:—

See Punjab Gazette Notification.—No. 388 dated 20th August, 1892, as above.

22nd September, 1892.—No. 201.—In supersession of so much of *Residency Orders* notification No. 256, dated the 24th August 1892, as relates to the pay of Mr. Martin, Probationary Extra Assistant Conservator of Forests in Berar, the Resident is pleased to direct that that officer shall draw Rs. 150 per mensem with effect from the 24th July 1892.

4th October, 1892.—No. 302.—The Resident is pleased to declare that Mr. E. M. Coventry, an Assistant Conservator of Forests, in Berar, has passed the examination prescribed for Forest Officers in the Hyderabad Assigned Districts in the subject and by the standard noted below:—

Lower Standard.

1. Land Revenue.
2. Forest Law.
3. Hindustani.

11.—MYSORE GAZETTE.

12th October, 1892.—No. 5162—G. 1242-92.—The 10 days' casual leave granted to Mr. B. Ramaswami Iyer, Officiating Assistant Conservator of Forests, Kadur District, in Notification No. 94 of the 4th May 1892, is hereby commuted into privilege leave and extended to 20 days with effect from such date as he may avail himself of the same.

VIII.—EXTRACTS FROM OFFICIAL GAZETTES.

1.—GAZETTE OF INDIA.

28th October, 1892.—No. 1326 F.—Furlough for one year, under Article 340 (b) of the Civil Service Regulations, is granted to Mr. A. E. Wild, Conservator of Forests, 3rd (officiating 2nd) Grade, Central Circle, North-Western Provinces and Oudh, with effect from the 23rd October 1892, or the subsequent date on which he may avail himself of it.

No. 1328 F.—With reference to the Notification of this Department, No. 532-F, dated the 6th May 1892, the appointment as Assistant Conservators of Forests, 2nd Grade, of the officers mentioned therein, took effect from the dates specified below instead of from those given in that Notification :

- Mr. Leete,—21st December 1891.
- „ Carr,—3rd January 1892.
- „ Tulloch,—21st December 1891.
- „ Edie.—21st December 1891.
- „ Hatt,—29th December 1891.
- „ Trafford,—29th December 1891.
- „ Long,—29th December 1891.

3rd November 1892.—No. 3221—45.—The services of Mr. E. C. Cotes, Officiating Deputy Superintendent of the Indian Museum, are transferred to the Forest School at Dehra Dún for two months, with effect from the 9th October 1892, and Mr. R. L. Chapman, Officiating First Assistant, is appointed to the charge of the current duties of the Deputy Superintendent during Mr. Cotes' absence.

4th November 1892.—No. 1421-F.—Mr. A. E. Wild, Conservator of Forests, 3rd (officiating 2nd) Grade, Central Circle, North-Western Provinces and Oudh, availed himself on the forenoon of the 25th October 1892 of the furlough granted him in the Notification of this Department, No. 1326-F., dated the 28th ultimo.

No. 1423 F.—The following appointments and reversions are made in consequence of the return to duty from furlough of Messrs. Bagshawe and Home, Conservators of Forest.

- | | | |
|---|---|--|
| <p>Mr. C. Bagshawe, Conservator, 2nd Grade, is appointed temporarily to the charge of the Central Circle in the North-Western Provinces and Oudh, and will officiate in the 1st Grade of Conservators until further orders.</p> <p>Mr. E. P. Dansey, Officiating 1st Grade Conservator, Bengal, reverts to the 2nd Grade of Conservators.</p> | } | <p>With effect from
25th October
1892.</p> |
|---|---|--|

Mr. A. L. Home, Conservator, 1st Grade, is appointed to the charge of the Western Circle in Upper Burma.
 Mr. R. H. C. Whittall, Officiating 1st Grade Conservator, Punjab, reverts to the 2nd Grade of Conservators.
 Mr. P. J. Carter, Officiating 2nd Grade Conservator, Pegu Circle, Lower Burma, reverts to the 3rd Grade Conservators.
 Mr. T. H. Aplin, Officiating Conservator, 3rd Grade, Western Circle, Upper Burma, reverts to his substantive appointment of Deputy Conservator, 2nd Grade.

With effect from
 28th October
 1892.

2.—MADRAS GAZETTE.

7th November, 1892.—No. 445.—Under the provisions of section 2 of the Madras Forest Act V of 1882, the Right Honorable the Governor in Council is pleased to empower the undermentioned officers to try forest offences :—

M. R. Ry. R. V. Krishnaswami Aiyar, Deputy Tahsildar and Third-class Magistrate of Denkanikota, in the district of Salem.

9th November, 1892.—M. R. Ry. C. Venkoba Rao, Deputy Tahsildar and Third-class Stationary Sub-Magistrate of Bellary, in the district of Bellary.

7th November, 1892.—No. 446.—Under the provisions of section 2 of the Madras Forest Act V of 1882, the Right Honorable the Governor in Council is pleased to empower the undermentioned Deputy Tahsildars and Third-class Magistrates of the South Arcot district to try forest offences :—

M. R. Ry. T. Ramanjulu Nayudu, Villupuram taluk.
 M. R. Ry. P. Narayana Chari, Tiruvannamalai taluk.
 M. R. Ry. S. Kristnaswami Aiyar, Tirukoilar taluk.
 M. R. Ry. V. Murugasa Pillai, Kallakurchi taluk.
 M. R. Ry. C. P. Doraswami Chetti, Tindivanam taluk.

7th November, 1892.—To Sub-Assistant Conservator Mr. T. G. A. Gaudoin leave for three months, from 1st December 1892, under article 291 of the Civil Service Regulations.

21st November, 1892.—No. 526.—Mr. T. N. Hearsey, Acting District Forest Officer, Kurnool, is granted privilege leave for one month, under article 291 of the Civil Service Regulations.

No. 527.—Mr. H. H. Ward, Acting District Forest Officer, Godavari, is granted privilege leave for three months, under article 291 of the Civil Service Regulations.

21st November, 1892—No. 530.—Appointments.

No.	Name and designation of officer.	Present grade.	Grade to which promoted or reverted.	Nature of promotion or reversion.	With effect from
1	Mr. A. W. Lushington ...	Deputy Conservator of Forests, Third Grade.	Deputy Conservator of Forests, Second Grade.	Acting ...	Date of Mr. Lushington joining his appointment as District Forest Officer, Kistna. Date of passing the Higher Standard in Telugu.
2	Mr. F. A. Ledge ...	Acting Deputy Conservator of Forests, Second Grade.	Deputy Conservator of Forests, Third Grade.	Permanent	
3	Mr. P. M. Lushington ...	Acting Assistant Conservator of Forests, First Grade.	Deputy Conservator of Forests, Fourth Grade.	Do. ...	

No. 531.—Posting.

No.	Name of officer.	Circle.	Nature of charge.	Remarks.
1	Mr. A. W. Peet ...	Northern Circle.	Conservator of Forests.	...

14th November, 1892.—The two months' leave granted to Ranger M. Shumsuddien Sahib and notified at page 1355, Part II of the *Fort St. George Gazette*, dated 4th October 1892, is extended by one month, i. e., up to 8th December 1892, and the acting arrangement made in consequence of his absence will continue.

3. BOMBAY GAZETTE.

27th October, 1892—No. 8431.—In exercise of the power conferred by Section 4 of the Indian Forest Act, No. VII of 1878, as amended by Act No. V of 1890, and in supersession of all notifications appointing Forest Settlement Officers in Sind, His Excellency the Governor in Council is pleased to appoint Mr. R. P. Barrow, I. C. S., to do duty as Forest Settlement Officer in Sind, for the purposes set forth in Section 4, clause (c), and Section 34 of the said Act, and in respect of all lands in the Province of Sind up to this date notified as proposed Reserved Forests under Section 4 or as Reserved Forests under Section 34, which have not since been disforested under Section 26, and in respect of which the enquiry into rights contemplated by clause (c) of Section 4 of the said Act has not yet been made.

2. Under Section 16 of the said Act His Excellency the Governor in Council is also pleased to appoint the Collectors and Deputy

Commissioners in Sind to hear appeals from any orders passed by the said Forest Settlement Officer under Sections 10, 11, 14 or 15 of the said Act.

3. His Excellency the Governor in Council is pleased to direct that the enquiry and record in respect of the Protected Forests of Sind shall be made and prepared in the same manner and subject to the same provisions and right of appeal as in the case of Reserved Forests.

4th November, 1892. Under paragraph 2 of Government Resolution No. 8315 of the 22nd October 1892, Mr. Dattatraya Manjunath Bijoor, substantive *pro tem*. Extra-Assistant Conservator of Forests, is appointed to do duty as Personal Assistant to the Conservator of Forests, Southern Circle.

8th November 1892 No.—8796.—His Excellency the Governor in Council is pleased to appoint Mr. R. H. Madan, L. C. E., on return from leave, to do duty as Divisional Forest Officer, East Khandesh ; and to post Mr. H. Mainwaring, on return to duty, to the Southern Circle as Working Plans Officer.

15th November, 1892, Messrs. W. R. Woodrow and G. K. Betham, Deputy Conservators, respectively delivered over and received charge of the Southern Division of Cauara on the forenoon of the 27th October 1892.

4.—BENGAL GAZETTE.

The 7th November, 1892.—No. 3824 F.—Mr. C. G. D. Fordyce, Deputy Conservator of Forests, in charge of the Chittagong Forest Division, is granted privilege leave for two months, under article 291 of the Civil Service Regulations, with effect from the forenoon of the 17th October, 1892.

8th November, 1892.—No.—3840—Mr. H. H. Davis, Deputy Conservator of Forests, having been permitted by the Secretary of State to return to duty within the period of the leave granted to him under the order dated the 4th June 1891, is posted to the charge of the Singhbhum Forest Division.

Mr. E. J. N. James, Extra-Assistant Conservator of Forests, on being relieved of the charge of the Singhbhum Forest Division by Mr. Davis, is attached to that Division for general duty.

11th November, 1892.—No.—3902.—Mr. F. Trafford, Assistant Conservator of Forests, on the expiry of the three months' examination leave granted to him in Notification, No. 2732 F. dated the 18th, July, 1892, is transferred to the Jalpaiguri Forest Division.

11th November, 1892.—No.—3903.—Mr. W. M. Green, Deputy Conservator of Forests, is appointed to be Personal Assistant to the Conservator of Forests, Bengal, from the date of his giving over charge of the Jalpaiguri Forest Division to Mr. F. B. Manson, Deputy Conservator of Forests.

11th November, 1892.—No.3904.—The following reversions are ordered in the Upper Controlling Staff of the Bengal Forest Department from the 30th September, 1892, the date on which Mr. F. B. Manson, Deputy Conservator of Forests, returned to duty from the leave granted to him in Notification, No. 2274 F. dated the 14th June 1892 :—

Mr. G. A. Richardson, Officiating Deputy Conservator of Forests, 2nd grade, to revert to his substantive appointment of Deputy Conservator, 3rd grade.

Mr. C. G. Rogers, Officiating Deputy Conservator of Forests, 3rd grade (on deputation), to revert to his substantive appointment of Deputy Conservator, 4th grade (seconded).

Mr. H. D. D. French, Officiating Deputy Conservator of Forests, 3rd grade, to revert to his substantive appointment of Deputy Conservator, 4th grade.

11th November, 1892.—No.—3905.—Mr. F. B. Manson, Deputy Conservator of Forests, in charge of the Jalpaiguri Forest Division, is posted to the charge of the Darjeeling Forest Division.

Mr. H. H. Haines, Officiating Deputy Conservator of Forests, in charge of the Darjeeling Forest Division, is posted to the charge of the Jalpaiguri Forest Division.

11th November, 1892.—No. 3906.—The following reversions are ordered in the Upper Controlling Staff of the Bengal Forest Department from the 15th October, 1892, the date on which Mr. C. A. G. Lillingston, Deputy Conservator of Forests, returned to duty from the leave granted to him in Notification, No. 3041 F. dated the 10th August 1892 :—

Mr. R. L. Heinig, Officiating Deputy Conservator of Forests, 3rd grade, to revert to his substantive appointment of Deputy Conservator, 4th grade.

Mr. W. H. Lovegrove, Officiating Deputy Conservator of Forests, 4th grade, to revert to his substantive appointment of Assistant Conservator, 1st grade.

15th November, 1892.—No.—3861.—Consequent on the grant of two months' privilege leave to Mr. C. G. D. Fordyce, Officiating Deputy Conservator of Forests, 2nd grade, the following promotions are ordered in the Upper Controlling Staff of the Bengal Forest Department, with effect from the 17th October, 1892, or until further orders :—

Mr. G. A. Richardson, Deputy Conservator of Forests, 3rd grade, to officiate in the 2nd grade of Deputy Conservators.

Mr. R. L. Heinig, Deputy Conservator of Forests, 4th grade, to officiate in the 3rd grade of Deputy Conservators.

Mr. W. H. Lovegrove, Assistant Conservator of Forests, 1st grade, to officiate in the 4th grade of Deputy Conservators.

15th November, 1892.—No.—3951.—Under the provisions of section 25 (i) of the Indian Forest Act (VII of 1878), the Lieutenant-Governor is pleased to sanction the closing of the Reserved Forests in the Darjeeling Terai and Lower hills (Kurseong and Tista Forest Divisions), as well as those in the district of Jalpaiguri (Jalpaiguri and Buxa Forest Divisions) against hunting, shooting and fishing from the 15th December, 1892, to the 15th June, 1893, except with the written permission of the Conservator of Forests or the Local Government.

15th November, 1892.—No.—3952.—Under the provisions of section 25 (i) of the Indian Forest Act (VII of 1878), the Lieutenant-Governor is pleased to sanction the closing of the Reserved Forests in the Singbhum, Palamau and Hazaribagh Forest Divisions against hunting, shooting and fishing from the 15th December, 1892, to the 15th June, 1893, except with the written permission of the Conservator of Forests or the Local Government.

15th November, 1892.—No. 3953.—Under the provisions of section 25 (c) of the Indian Forest Act (VII of 1878), the Lieutenant-Governor is pleased to sanction the closing of the Reserved Forests in the Puri and Angul Forest Divisions against hunting and shooting from the 15th December, 1892, to the 15th June, 1893, except with the written permission of the Conservator of Forests or the Local Government.

5.—N. W. PROVINCES AND OUDH GAZETTE.

10th November, 1892.—No. 8780.—Under section 14 of Act X of 1882, Mr. B. A. Rebsch, Deputy Conservator of Forests, Bahraich, is appointed a Special Magistrate and is invested with the powers of a Magistrate of the 3rd class, within the limits of any Forest Division of which he may be in charge, for the trial of offences punishable under Act VII of 1878.

25th November 1892.—No. 5373.—With effect from the 24th June 1892, the date on which Mr. B. B. Osmaston proceeded on leave—

Mr. A. P. Grenfell, Assistant Conservator of Forests, 1st grade, to officiate as Deputy Conservator of Forests, 4th grade.

No.—5374, With effect from the 1st August 1892 the date on which Mr. N. Hearle proceeded on privilege leave.

Mr. A. G. Hobart-Hampden, Officiating Deputy Conservator of Forests, 3rd grade, to officiate as Deputy Conservator of Forests, 2nd grade ;

Mr. L. Mercer, Deputy Conservator of Forests, 4th grade, to officiate as Deputy Conservator of Forests, 3rd grade.

No.—5375. With effect from the 28th October 1892, the date on which Mr. N. Hearle returned from privilege leave and took charge of the Dehra Dún Forest Division—

Mr. A. G. Hobart-Hampden, Officiating Deputy Conservator of Forests, 2nd grade, to officiate as Deputy Conservator of Forests, 3rd grade ;

Mr. L. Mercer, Officiating Deputy Conservator of Forests, 3rd grade, to revert to his substantive appointment as Deputy Conservator of Forests, 4th grade.

6.—PUNJAB GAZETTE.

3rd November 1892.—No. 497.—Mr. C. F. Rossiter and Babu Latha Singh, Extra Assistant Conservators of Forests, respectively made over and received charge of the Montgomery Forest Division on the afternoon of the 5th October 1892, consequent on the former's departure on three months' privilege leave.

7.—CENTRAL PROVINCES GAZETTE.

1st November 1892.—No-4142.—The designation "Sub-Assistant Conservator" having been superseded by that of "Extra-Assistant Conservator," with effect from the 26th of February 1891, the Chief Commissioner is pleased to direct that from the date above specified the term "Sub-Assistant Conservators" as used in Notifications

already issued under Act VII of 1878, and under Act VII of 1887 amended by Act V of 1890, shall be held to mean "Extra-Assistant Conservators."

10th November 1892.—No. 4292.—Mr. Chunder Kumar Chatterji, Extra-Assistant Conservator of Forests, is transferred from the Chhindwara to the Nagpur Division.

10th November 1892.—No. 4293.—With reference to Notification No. 4292, dated the 18th November 1892, Mr. Chunder Kumar Chatterji and Mr. M. W. Fox-Strangways, I C. S., Deputy Commissioner, Chhindwara, respectively surrendered and received charge of the Chhindwara Forest Division on the afternoon of the 26th October 1892.

10th November 1892.—No. 4294.—With reference to Notification No. 4292, dated the 10th November 1892, Mr. Chunder Kumar Chatterji, Extra-Assistant Conservator of Forests, assumed charge of his duties in the Nagpur Division on the afternoon of the 31st October 1892.

13th November 1892.—No. 4373.—Privilege leave for three months, under Articles 277 and 291 of the Civil Service Regulations, is granted to Mr. P. H. Clutterbuck, Assistant Conservator of Forests, Raipur, with effect from the forenoon of the 6th instant, on which date he availed himself of it.

Notification No. 3596, dated the 28th September 1892, is hereby cancelled.

15th November 1892.—No. 4402.—In Notifications Nos. 3177 and 3178, dated the 5th September 1892, Serial No. 20 in both lists, and in the last columns, Mr. J. L. Pigot should be shown as "Officiating Deputy Conservator of Forests, 3rd grade, seconded on deputation," with effect from the 29th December 1891.

24th November 1892.—No. 4536.—With reference to Government of India, Revenue and Agricultural Department (Forests), Notification No. 1328-F, dated the 28th October 1892, the name of Mr. H. S. Ker Edie, as a Supernumerary Assistant Conservator of Forests of the 2nd grade, is added at the end of the list published in Notification No. 3177, dated the 5th September 1892, showing the names and position of the officers on the combined Punjab—Central Provinces—Berar—Coorg list on the 29th December 1891.

8.—BURMA GAZETTE.

19th October 1892.—No. 362.—The Chief Commissioner appoints Mr. D. L. Richardson, Myoók, to succeed the Deputy Commissioner, Katha, as Forest Settlement officer, for the purpose of the enquiry ordered in this Department Notification No. 167, dated the 2nd October 1890.

No. 363.—The Chief Commissioner appoints Mr. D. L. Richardson, Myoók, to succeed the Deputy Commissioner, Katha, as Forest Settlement Officer, for the purpose of the enquiry ordered in this Department Notification No. 38, dated the 27th February 1890.

22nd October 1892.—No. 364.—Mr. G. R. Long, Assistant Conservator of Forests, is transferred from the Toungoo Forest Division to the charge of the Myanaung subdivision of the Western division, Pegu Circle.

No. VIIB.—Trade license for the extraction of Kalamet and Tô-nwè in the Mergui district.

License to cut, saw, convert, remove, or otherwise utilize kalamet, tô-nwè trees to the extent of _____ viss is granted under Rule 8 of the Forest Rules to _____ of _____ in _____ Forest, _____ circle, Mergui district for _____ months from date of this license under the following conditions :—

- (1) That payment is made at the rate of Rs. 2, annas 6 per 100 viss for kalamet, tô-nwè, or at such lower rates as may be fixed by the Conservator at such places and at such times as may be entered on the reverse.
- (2) That only dead kalamet wood shall be cut, sawn, converted, removed or otherwise utilized.
- (3) That the license is not transferable and must be in the possession of the person to whom it was granted or of his agent, when such person or his agent is felling the timber covered by it.
- (4) That the timber extracted on this license shall not be utilized before it has been paid for in full.
- (5) That breach of any of the above conditions shall render the holder of the license liable to forfeiture of the license and confiscation of the timber, as well as to the punishment provided in the Forest rules.

9.—ASSAM GAZETTE.

27th October, 1892.—No. 9638 G.—The following is published :

The undermentioned officer has been granted by Her Majesty's Secretary of State for India permission to returned to duty, as advised in List dated the 19th August, 1892 :

Name.	Service.	Appointment.	Date on which permitted to return.
Mr. J. E. Barrett	...	Assistant Conservator of Forests.	Within period of leave.

- Mr. C. W. Palmer, Deputy Conservator, 2nd (officiating 1st) grade, to revert to his substantive appointment.
- Mr. H. B. Anthony, Deputy Conservator, 4th (officiating 2nd) grade, to officiate as Deputy Conservator, 3rd grade.
- Mr. G. F. R. Blackwell, Assistant Conservator, 1st grade (officiating Deputy Conservator, 3rd grade), to officiate as Deputy Conservator, 4th grade.
- Mr. C. W. A. Bruce, Assistant Conservator, 2nd grade (officiating Deputy Conservator, 4th grade), to officiate as Assistant Conservator, 1st grade.
- Mr. C. R. Dun, Assistant Conservator, 2nd grade (officiating Deputy Conservator, 4th grade), to officiate as Assistant Conservator, 1st grade.

No. 398.—The Chief Commissioner appoints the Forest Officer in charge of the Yaw Forest division to assist the Forest Settlement officer in the enquiries ordered in this department Notification No. 11, dated the 21st January 1892, and No. 244, dated the 19th August 1892.

2nd November 1892.—No. 11.—Mr. E. A. O'Bryen, Deputy Conservator of Forests, reported his return from the privilege leave granted him in Revenue Department Notification No. 209 of the 29th June 1892, on the forenoon of the 24th October 1892.

5th November 1892.—No. 9.—Mr. C. W. A. Bruce, officiating Deputy Conservator of Forests, reported his return from the privilege leave granted him in Revenue Department Notification No. 224, dated the 4th August 1892, on the forenoon of the 4th November 1892.

8th November 1892.—No. 12.—With reference to Revenue Department Notification No. 390 (Forests), dated Rangoon, the 3rd November 1892, Mr. W. T. T. McHarg and Mr. E. A. O'Bryen, officiating Deputy Conservators of Forests, respectively made over and received charge of the Katha Forest division on the forenoon of the 4th November 1892.

8th November 1892.—No. 23.—With reference to Revenue Department Notification No. 382 (Forests), dated the 2nd instant, Mr. G. Q. Corbett, Deputy Conservator of Forests, made over, and Mr. H. Slade, Deputy Conservator of Forests, received charge of, the Tharrawaddy division on the forenoon of the 7th instant.

8th November 1892.—No. 24.—Mr. H. Slade, Deputy Conservator of Forests, reported his return from furlough granted him in Revenue Department Notification No. 53, dated the 12th March 1891, on the forenoon of the 5th instant.

14th November 1892.—No. 405.—The following alterations of rank are ordered in the Forest Department :—

- (1) With effect from the 28th October 1892, consequent on the return of Mr. C. H. Hobart-Hamden from privilege leave :
 - Mr. H. Calthrop, Deputy Conservator, 4th (officiating 3rd) grade, to revert to his substantive appointment.
 - Mr. W. T. T. McHarg, Assistant Conservator, 2nd grade (officiating Deputy Conservator, 4th grade), to officiate as Assistant Conservator, 1st grade.
- (2) With effect from the 3rd November 1892, consequent on the departure of Mr. Herbert Carter on privilege leave :
 - Mr. W. T. T. McHarg, Assistant Conservator, 2nd (officiating 1st) grade, to officiate as Deputy Conservator, 4th grade.

[R E P O R T]
 ON THE
SEA-BORNE TRADE IN THE TIMBERS OF BURMA.

BY
F. J. BRANTHWAITE,
 DEPUTY CONSERVATOR OF FORESTS.
 BURMA.

I.—HISTORY OF THE SEA-BORNE TRADE IN TEAK.

Figures are available from 1855-56, which show the tonnage and value of the Teak timber exported from Moulmein and Rangoon to various other ports. These ports may be arranged under three heads, *viz.*,—

- (1) Internal ports, *i.e.*, the ports of Hindustan ;
- (2) Foreign or external ports ;
- (3) Provincial ports, including the Andamans.

Taking the first decade for which we have figures available, we find that the amount of timber exported and its value increased steadily for both ports.

From Rangoon to all ports in—

	Tons.	Value. R	
1855-56 : : : : :	2,342	1,40,809	}
1864-65 : : : : :	26,251	14,56,887	

were exported.

i.e., the amount increased eleven-fold in the ten years, the money value increasing about ten-fold.

From Moulmein to all ports in—

	Tons.	Value. R	
1855-56 : : : : :	28,777	14,38,956	}
1864-65 : : : : :	114,363	68,37,942	

were exported.

i.e., the amount of timber increased about four-fold during the ten years, whilst its value increased by rather more than 4½ times.

The total amount of timber exported from Rangoon during the ten years was 108,339 tons, valued at R81,66,244, *i.e.*, over R56 per ton. Though Moulmein exported over six times as much timber,

viz., 687,602 tons, valued at Rs,72,89,411, the quality apparently was not quite so good, as the average value was only about Rs54 per ton. With reference to the timber shipped to external ports, of that exported from Rangoon about half, whilst of that exported from Moulmein nearly the whole was for the United Kingdom.

During these ten years the price of Teak in the round log varied from Rs12½ to Rs32½ per ton, taking as our criterion the prices realized by Government on the timber sold by it.

In the second decade and after, I have arranged the figures somewhat differently, as the amount exported to Provincial ports was comparatively small and has decreased steadily. These ports are, in the tables showing the export of Teak, included in the internal ports.

An examination of the table showing the exports from 1865-66 to 1874-75 shows—

- (i) that the export trade in Teak from Rangoon to Foreign ports increased at an enormous rate—in fact the amount in tons more than quadrupled itself—whilst the money value of the timber increased more than five-fold. These figures, owing to two bad years, are considerably reduced for the total increase. The trade of Rangoon with Indian ports remained fairly stationary.
- (ii) that the trade from Moulmein to both Foreign and Indian ports decreased, but showed signs of reviving during the last three years of the decade. For the ten years, whilst the trade of Rangoon more than doubled itself in amount and nearly trebled in money value, that of Moulmein only increased in tonnage about 8 per cent., and in value between 12 and 13 per cent, as compared with the totals for the same ports for the years 1855-56 to 1864-65.

During the ten years in question the market value of Teak in the log, as shown by the prices realized at the Government sales, varied from Rs20½ to Rs39½ per ton as against Rs12½ to Rs32½ per ton (for teak in the round log) in the previous ten years.

I can find no information as to the percentage sent to the United Kingdom during this period.

1875-76 to 1884-85.

The figures for these ten years show great variations, especially during the last two years, *viz.*, 1883-84-1884-85. In these two years the total export of Teak from Rangoon rose most wonderfully, whilst in Moulmein it decreased.

During the ten years the trade with Indian ports from Rangoon and Moulmein was almost double of that with foreign ports.

The total trade from Rangoon doubled itself in value; that of Moulmein increased by about three-fifths, but still the trade from Moulmein was more than double that from Rangoon.

1885-1891.

During this period the trade from Rangoon went on increasing, reaching last year (1890-91) 110,675 tons, while that of Moulmein decreased steadily. Last year (1890-91) it was only 64,227 tons. It was exceeded for the first time by Rangoon in 1889-90.

Table showing Total Teat exported from 1855-56 to 1864-65.

YEAR	INTERNAL PORTS.				FOREIGN PORTS.				PROVINCIAL PORTS.			
	FROM RANGOON.		FROM MOULMEIN.		FROM RANGOON.		FROM MOULMEIN.		FROM RANGOON.		FROM MOULMEIN.	
	Tons.	Value.	Tons.	Value.	Tons.	Value.	Tons.	Value.	Tons.	Value.	Tons.	Value.
1855-56 .	2,315	R 1,38,934	6,956	2,97,887	22	R 1,331	21,167	10,57,873	5	R 324	1,664	R 88,277
1856-57 .	3,508	2,10,488	7,396	3,09,877	43	2,581	33,865	16,47,337	26	1,559	1,086	83,337
1857-58 .	964	57,861	27,051	10,12,155	186	11,214	40,804	18,63,233	34	2,174	1,716	74,883
1858-59 .	8,915	5,34,920	36,050	17,57,060	4,044	2,42,078	40,671	19,54,168	16	975	809	35,622
1859-60 .	4,983	2,83,021	22,125	12,06,763	2,723	1,65,394	37,365	19,45,853	728	37,803
1860-61 .	2,601	1,48,067	26,629	14,77,564	3,540	2,13,414	25,751	14,49,589	206	12,348	1,850	38,816
1861-62 .	1,978	1,09,668	38,493	23,91,701	10,328	6,77,319	57,944	37,00,483	272	15,670	1,583	70,702
1862-63 .	7,509	4,09,942	39,889	21,27,416	8,043	4,70,650	34,064	31,39,222	229	10,610	716	35,385
1863-64 .	4,788	2,45,925	39,067	21,50,304	14,567	8,04,911	26,493	15,03,290	186	7,463	1,180	75,847
1864-65 .	18,503	10,45,997	55,431	30,48,102	7,448	8,93,357	53,283	35,91,868	300	17,533	3,049	2,07,083
TOTAL .	86,171	52,17,800	2,99,008	1,57,37,797	50,044	28,70,887	3,71,097	2,08,40,949	1,224	66,548	14,099	7,11,673

Teak exported.

Decade.	TO FOREIGN PORTS.				TO INDIAN PORTS.				TOTAL.			
	FROM RANGOON.		FROM MOULMEIN.		FROM RANGOON.		FROM MOULMEIN.		FROM RANGOON.		FROM MOULMEIN.	
	Tons.	Value.	Tons.	Value.	Tons.	Value.	Tons.	Value.	Tons.	Value.	Tons.	Value.
1855-59		R										
1860-65	50,914	28,79,882	3,74,087	2,08,49,942	87,895	32,86,363	3,19,565	1,64,89,469	1,08,339	61,69,244	6,97,602	8,72,69,411

Teak exported.

Year.	TO FOREIGN PORTS.				TO INDIAN PORTS.				TOTAL.			
	FROM RANGOON.		FROM MOULMEIN.		FROM RANGOON.		FROM MOULMEIN.		FROM RANGOON.		FROM MOULMEIN.	
	Tons.	Value.	Tons.	Value.	Tons.	Value.	Tons.	Value.	Tons.	Value.	Tons.	Value.
1865-66	4,618	2,72,339	42,571	26,14,049	19,516	11,69,556	76,493	45,52,795	91,134	14,41,696	1,18,976	73,67,634
1866-67	2,665	1,59,740	15,088	10,09,028	16,528	9,33,539	33,101	20,78,486	19,243	10,68,799	48,189	30,84,316
1867-68	6,496	3,96,126	14,657	9,44,498	13,927	7,49,188	47,598	24,18,285	17,423	9,46,312	62,265	35,62,964
1868-69	4,710	3,01,264	36,610	22,61,003	12,169	7,30,124	63,812	34,70,716	19,609	10,31,980	98,833	69,31,718
1869-70	6,233	6,62,305	12,356	7,98,758	18,643	11,37,375	63,413	31,73,698	26,916	16,89,090	64,769	39,73,344
1870-71	9,634	6,14,652	23,299	15,94,295	16,931	9,38,589	30,608	16,73,163	26,465	15,61,241	53,804	32,67,468
1871-72	14,907	9,29,045	27,733	19,93,433	15,480	9,05,021	29,267	16,34,048	30,297	18,34,048	67,000	36,65,516
1872-73	16,944	10,63,955	36,956	26,19,350	20,400	11,70,318	33,703	22,34,173	36,344	22,34,173	78,657	46,93,329
1873-74	16,399	11,04,072	34,888	26,71,450	14,658	9,58,434	61,473	31,53,862	30,067	20,65,468	96,361	66,24,632
1874-75	16,524	14,60,708	23,650	17,87,818	20,642	15,40,413	63,969	33,33,770	36,166	29,61,121	76,639	61,21,688
Total.	97,960	66,56,226	2,65,716	1,84,93,672	1,69,964	1,02,09,447	4,79,397	2,82,99,267	2,66,954	1,68,46,673	7,45,083	4,67,92,959

Teak exported—continued.

YEAR.	TO FOREIGN PORTS.						TO INDIAN PORTS.						TOTAL.	
	FROM BANGOOK.		FROM MOULMEIN.		FROM BANGOOK.		FROM MOULMEIN.		FROM BANGOOK.		FROM MOULMEIN.		Tons.	Value.
	Tons.	Value.	Tons.	Value.	Tons.	Value.	Tons.	Value.	Tons.	Value.	Tons.	Value.	Tons.	Value.
1876-76	26,311	R 17,88,669	34,270	R 25,29,115	33,459	R 23,91,561	70,999	R 46,02,234	57,770	R 41,90,260	1,05,169	R 71,31,589	1,05,169	R 71,31,589
1876-77	18,773	13,96,053	24,102	19,12,979	20,374	14,68,443	53,431	32,79,671	55,147	23,66,495	78,533	51,95,350	78,533	51,95,350
1877-78	17,904	12,93,943	36,383	27,07,954	20,050	14,13,203	84,859	51,51,453	37,934	26,96,145	1,23,243	78,59,106	1,23,243	78,59,106
1878-79	14,247	10,36,663	31,376	16,56,015	16,365	11,61,349	81,331	45,76,460	30,613	21,89,013	1,03,207	61,31,475	1,03,207	61,31,475
1879-80	6,561	4,74,663	23,049	23,09,594	17,185	11,13,316	65,366	37,36,760	23,470	15,87,969	97,415	60,34,344	97,415	60,34,344
1880-81	17,633	12,96,967	46,563	36,19,995	19,943	13,81,374	66,535	39,16,955	37,876	24,69,361	1,13,366	75,29,960	1,13,366	75,29,960
1880-81	...	61,650	...	61,650	4,91,781	...	4,91,781
1881-82	8,913	7,53,071	46,538	43,48,491	13,833	11,61,310	64,768	43,36,763	23,445	19,14,231	1,11,906	84,75,244	1,11,906	84,75,244
1881-82	...	4,109	...	4,109	1,89,187	...	1,89,187
1882-83	16,031	14,89,690	48,115	46,34,309	24,473	24,19,696	69,533	56,03,145	39,503	39,09,356	1,11,648	1,01,37,354	1,11,648	1,01,37,354
1883-84	20,943	21,30,774	23,376	26,47,294	47,107	47,36,456	66,984	61,42,743	65,049	60,06,330	90,349	89,90,041	90,349	89,90,041
1884-85	17,299	16,30,143	37,496	33,39,997	34,889	30,09,521	69,353	53,45,150	53,138	46,39,664	96,848	85,79,117	96,848	85,79,117
1884-85	...	81,719	...	81,719	1,39,584	...	1,39,584
Total . . .	1,69,904	1,26,11,664	3,39,367	3,04,99,067	3,46,305	3,02,34,998	6,90,948	4,65,69,283	4,09,309	3,37,46,633	10,30,115	7,00,61,330	10,30,115	7,00,61,330
	...	4,809	...	5,46,310	...	1,46,979	...	7,30,984	9,67,344	...	9,67,344
GRAND TOTAL	...	1,35,16,463	...	3,07,36,347	...	3,08,81,678	...	4,73,00,317	...	3,38,08,141	...	7,70,39,666	...	7,70,39,666

Figures italicized denote value of converted timber.

Teak exported—continued.

YEAR.	TO FOREIGN PORTS.				TO INDIAN PORTS.				TOTAL.			
	FROM BANGCOON.		FROM MOULMEIN.		FROM BANGCOON.		FROM MOULMEIN.		FROM BANGCOON.		FROM MOULMEIN.	
	Tons.	Value.	Tons.	Value.	Tons.	Value.	Tons.	Value.	Tons.	Value.	Tons.	Value.
1866-66 .	21,948 }	23,73,517 9,070	24,435	28,04,328 41,710	41,425	29,96,813 265	80,805	55,04,832 87,971	68,368	53,72,330 2,886	1,06,240	88,09,160 96,681
1866-67 .	10,942 }	9,81,512 7,699	11,244	11,26,410 39,250	35,792	25,05,049 26,635	85,356	51,09,591 74,997	46,734	34,66,551 38,384	96,600	63,24,971 1,14,597
1867-68 .	F. 14,968 }	12,04,983	21,209	20,92,350 45,045	37,449	24,94,927 41,401	95,398	58,62,468 211,469	54,417	36,99,910 41,401	1,16,507	79,54,813 866,647
1868-69 .	F. 17,870 }	19,81,090 5,487	31,875	35,78,044 75,063	45,099	29,49,517 16,064	61,490	41,43,775 185,519	62,969	45,99,547 21,601	98,466	77,31,819 198,695
1869-70 .	39,160 }	39,74,371	28,694	35,45,958 75,963	64,380	42,10,473 3,530	52,177	38,81,999 192,747	1,09,660	81,84,843 8,680	80,971	70,05,857 803,700
1870-71 .	25,910 }	25,66,474	11,503	11,55,140	64,765	52,94,540 12,780	52,784	35,46,294 1,948	1,10,675	78,93,014 12,780	64,327	47,01,434 1,548
TOTAL .	1,80,913 }	190,31,897 16,106	1,28,980	1,41,00,230 2,73,654	3,03,910	204,54,018 99,216	4,27,950	278,27,823 6,01,568	4,39,723	384,85,905 1,14,929	5,66,910	419,28,023 8,76,499

Figures italicised denote value of converted timber.

Average selling rates of teak in the home market per load.

Month.	1880-81.		1881-82.		1882-83.		1883-84.		1884-85.		1885-86.		1886-87.		1887-88.		1888-89.		1889-90.		1890-91.		
	Churchill and Slim's.		Churchill and Slim's.		Clyde.		Churchill and Slim's.		Clyde.		Churchill and Slim's.		Churchill and Slim's.		Churchill and Slim's.		Churchill and Slim's.		Churchill and Slim's.		Churchill and Slim's.		
	£ s. d.	£ s. d.	£ s. d.	£ s. d.	£ s. d.	£ s. d.	£ s. d.	£ s. d.	£ s. d.	£ s. d.	£ s. d.	£ s. d.	£ s. d.	£ s. d.	£ s. d.	£ s. d.	£ s. d.	£ s. d.	£ s. d.	£ s. d.	£ s. d.	£ s. d.	£ s. d.
April	15 0 0	13 10 0	14 0 0	13 3 4	14 0 0	16 0 0	16 0 0	16 5 0	13 15 0	14 5 0	13 0 0	14 5 0	11 10 0	10 10 0	10 10 0	10 10 0	10 10 0	10 10 0	10 10 0	13 0 0	13 0 0	13 0 0	13 0 0
May	15 0 0	14 7 6	14 0 0	13 13 10	14 0 0	16 0 0	16 5 0	16 5 0	14 5 0	13 0 0	13 0 0	14 5 0	10 10 0	10 10 0	10 10 0	10 10 0	10 10 0	10 10 0	10 10 0	13 0 0	13 0 0	13 0 0	13 0 0
June	15 0 0	14 0 0	14 0 0	13 3 4	14 0 0	16 0 0	16 0 0	15 0 0	14 5 0	13 0 0	13 0 0	14 5 0	10 10 0	10 10 0	10 10 0	10 10 0	10 10 0	10 10 0	10 10 0	13 0 0	13 0 0	13 0 0	13 0 0
July	14 10 0	13 15 0	14 0 0	13 10 6	14 0 0	16 0 0	16 0 0	13 15 0	14 5 0	13 0 0	13 0 0	14 5 0	10 10 0	10 10 0	10 10 0	10 10 0	10 10 0	10 10 0	10 10 0	13 0 0	13 0 0	13 0 0	13 0 0
August	14 10 0	13 5 6	14 0 0	14 1 0	14 15 0	16 0 0	16 0 0	13 15 0	14 5 0	12 0 0	12 0 0	14 5 0	10 10 0	10 10 0	10 10 0	10 10 0	10 10 0	10 10 0	10 10 0	13 15 0	13 15 0	11 5 0	11 5 0
September	14 10 0	13 5 6	14 0 0	13 15 0	14 15 0	16 0 0	16 0 0	13 15 0	14 5 0	12 0 0	12 0 0	14 5 0	10 10 0	10 10 0	10 10 0	10 10 0	10 10 0	10 10 0	10 10 0	13 15 0	13 15 0	11 5 0	11 5 0
October	14 10 0	13 0 0	14 0 0	13 0 0	14 15 0	16 5 0	16 5 0	13 15 0	14 5 0	12 0 0	12 0 0	14 5 0	10 10 0	10 10 0	10 10 0	10 10 0	10 10 0	10 10 0	10 10 0	13 15 0	13 15 0	11 5 0	11 5 0
November	14 10 0	12 17 0	14 0 0	13 8 10	14 15 0	16 5 0	16 5 0	13 15 0	14 5 0	12 0 0	12 0 0	14 5 0	10 10 0	10 10 0	10 10 0	10 10 0	10 10 0	10 10 0	10 10 0	13 15 0	13 15 0	11 5 0	11 5 0
December	14 10 0	12 15 0	14 0 0	13 0 0	14 15 0	16 5 0	16 5 0	13 15 0	14 5 0	12 0 0	12 0 0	14 5 0	10 10 0	10 10 0	10 10 0	10 10 0	10 10 0	10 10 0	10 10 0	13 15 0	13 15 0	11 5 0	11 5 0
January	...	15 0 0	14 0 0	13 3 2	14 15 0	16 5 0	16 5 0	13 15 0	14 5 0	11 10 0	11 10 0	14 5 0	10 10 0	10 10 0	10 10 0	10 10 0	10 10 0	10 10 0	10 10 0	13 0 0	13 0 0	11 5 0	11 5 0
February	14 10 0	13 3 6	14 0 0	13 18 4	15 5 0	16 5 0	16 5 0	13 15 0	14 5 0	11 10 0	11 10 0	14 5 0	10 10 0	10 10 0	10 10 0	10 10 0	10 10 0	10 10 0	10 10 0	13 0 0	13 0 0	11 5 0	11 5 0
March	14 10 0	13 5 0	14 0 0	13 12 6	15 5 0	16 5 0	16 5 0	13 15 0	14 5 0	11 10 0	11 10 0	14 5 0	10 10 0	10 10 0	10 10 0	10 10 0	10 10 0	10 10 0	10 10 0	13 0 0	13 0 0	11 5 0	11 5 0
Average price per load	14 13 10	13 10 3	14 0 0	13 9 1	14 11 8	16 3 6	14 5 5	14 4 2	13 6 3	10 11 8	11 1 5	13 0 3	11 10 8	11 1 5	13 0 3	11 10 8	11 10 8	11 10 8	11 10 8	13 0 3	13 0 3	11 10 8	11 10 8

Average Rangoon rates for 1st and 2nd class timber in the round obtained at the sales at the Government Depot.

	1890-91.		1891-92.		1892-93.		1893-94.		1894-95.		1895-96.		1896-97.		1897-98.		1898-99.		1899-00.		1900-01.		
	1st class.	2nd class.	1st class.	2nd class.	1st class.	2nd class.	1st class.	2nd class.	1st and 2nd classes.	1st and 2nd classes.	1st and 2nd classes.	1st and 2nd classes.	1st and 2nd classes.	1st and 2nd classes.	1st and 2nd classes.	1st and 2nd classes.	1st and 2nd classes.	1st and 2nd classes.	1st and 2nd classes.	1st and 2nd classes.	1st and 2nd classes.	1st and 2nd classes.	
April	R a. P. Nil	R a. P. Nil	R a. P. Nil	R a. P. Nil	R a. P. Nil	R a. P. Nil	R a. P. Nil	R a. P. Nil	R a. P. 46 1 10	R a. P. 25 9 5	R a. P. 36 6 9	R a. P. 35 3 1	R a. P. 45 8 11	R a. P. 54 0 6	R a. P. 59 11 7								
May	45 5 0	27 3 4	64 15 4	47 13 10	57 1 8	40 3 11	Nil	Nil	66 7 9	40 5 7	31 5 10	35 1 2	37 9 2	35 0 11	45 15 5	49 9 7	33 9 1						
June	43 1 4	28 9 2	59 6 9	40 11 5	65 9 10	47 10 5	74 1 4	46 4 0	Nil	57 6 0	37 11 11	50 3 11	35 4 0	33 11 5	49 10 3	50 13 6	33 7 7						
July	36 0 0	26 6 6	53 10 3	36 15 6	53 14 2	52 8 11	Nil	57 6 0	Nil	67 11 5	34 3 11	35 3 2	39 1 3	35 3 8	43 13 7	51 4 2	23 14 8						
August	Nil	25 4 8	65 14 4	35 11 8	73 2 3	53 9 10	Nil	53 6 1	Nil	53 6 1	34 3 7	40 10 2	43 11 9	39 0 11	47 13 9	53 12 1	36 10 11						
September	47 7 4	30 13 3	70 2 5	42 13 7	74 6 5	50 0 11	Nil	53 6 1	Nil	53 6 1	34 3 7	40 10 2	43 11 9	39 0 11	47 13 9	53 12 1	36 10 11						
October	44 6 5	42 1 6	Nil	Nil	55 7 7	51 3 11	103 13 0	90 9 0	26 8 8	37 4 11	46 5 8	37 6 6	45 6 6	33 7 6	45 6 6	49 14 1	54 15 7						
November	47 2 10	33 10 10	Nil	Nil	56 1 2	44 10 0	88 8 7	90 10 0	30 14 8	36 13 9	43 1 6	37 15 2	Nil	43 6 9	35 9 9	49 14 1	54 15 7						
December	49 4 0	35 7 7	73 8 10	38 8 6	Nil	Nil	79 7 7	76 15 0	38 9 8	31 3 11	39 13 6	39 12 10	61 6 10	51 11 11	37 10 8								
January	Nil	Nil	80 4 2	51 8 6	63 4 0	53 11 1	Nil	Nil	29 7 2	36 8 1	31 9 6	38 7 4	Nil	45 6 11	43 10 1								
February	55 13 8	38 9 7	69 0 4	41 2 6	69 6 3	55 0 10	59 13 5	Nil	33 4 0	33 13 6	37 12 0	47 5 2	54 3 10	53 5 6	45 10 1								
March	53 1 3	41 3 9	60 1 8	43 6 11	76 4 9	46 15 9	53 3 2	Nil	29 1 7	41 0 6	37 11 0	45 6 0	50 14 0	36 1 3	42 11 9								

Supplementary Table showing the Exports of Teak to the United Kingdom during the last 16 years.

Year.	Value. £	Tons.
1875-76	39,57,279	54,194
1876-77	28,75,061	38,433
1877-78	35,36,412	49,310
1878-79	21,21,702	29,447
1879-80	19,98,230	25,511
1880-81	45,19,803	58,683
1881-82	44,52,075	48,959
1882-83	51,78,211	50,221
1883-84	30,74,007	27,023
1884-85	39,01,749	33,319
Total ...	356,14,529	415,200
1885-86	41,83,350	36,573
1886-87	17,22,341	17,441
1887-88	19,00,086	19,596
1888-89	43,13,121	38,785
1889-90	64,71,769	60,112
1890-91	31,51,115	30,915
Total ...	217,41,732	203,422

II.—HISTORY OF EXPORT TRADE OF TIMBER OTHER THAN TEAK.

As in the case of Teak, I am only dealing with the ports of Rangoon and Moulmein, though small quantities are exported from Mergui, Tavoy, and Akyab.

Many attempts have been made to introduce woods other than Teak into the market, *e.g.*, in 1872-73.

Thinwin (*Pongamia glabra*), which resembles the rose-wood of Southern India, was sent for trial to the cabinet-makers of Calcutta and Madras and to England. It was not favourably reported on, the hardness of the grain rendering it very difficult to work. A piece was also tested by a local firm for machinery bearings, but was found unsuitable.

Thitka (*Pentace burmanica*) and Thitkado (*Cedrela Toona*) were sent to England; but no hope of a large and steady demand for these woods was held out, as they could not compete in price with the bastard mahogany and cedar wood from South America. The sale of small quantities in Calcutta was however attended with some success, £65 to £68 per ton being realized.

Sample shipments of Padauk, Thingan, and Anan were also made.

1873-74.

1,330 tons of Thitka were exported from Moulmein, 1,105 tons going to England. From the same port were exported 50 tons of Padauk to Madras, 88 tons of Pyinma to Calcutta, and 50 tons of Thingan to Dacca. From Akyab 82 tons of Pyinkado (*Xylia dolabriformis*) were exported to India.

1874-75.

618 tons of Thitka and Thitkado and 576 tons of Padauk, Ingyin, Pyinkado, etc., were exported from Moulmein to India.

1875-76.

146 tons of Padauk were sold by the department to the Madras Gun Carriage Factory at a net profit of R49-8 per ton.

The exports of wood other than Teak from 1875-76 are shown in the tables on page 12.

Exports of Timber other than Teak (unconverted).

YEAR.	TO FOREIGN PORTS.						TO INDIAN PORTS.						TOTAL			
	FROM RANGOON.		FROM MOULMEIN.		FROM RANGOON.		FROM MOULMEIN.		FROM RANGOON.		FROM MOULMEIN.		FROM RANGOON.		FROM MOULMEIN.	
	Tons.	Value.	Tons.	Value.	Tons.	Value.	Tons.	Value.	Tons.	Value.	Tons.	Value.	Tons.	Value.	Tons.	Value.
1875-76	5	R	551	27,645	...	R	204	6,261	...	5	R	755	33,906		R	33,906
1876-77	17	605	461	26,390	1,229	40,224	...	461	26,390	1,246	40,829		1,246	40,829
1877-78	25	1,122	380	25,110	613	29,736	...	380	25,110	638	30,568		638	30,568
1878-79	35	1,635	31	1,115	37	1,882	558	21,335	...	72	3,517	589	22,450		589	22,450
1879-80	2	34	182	7,515	29	449	584	21,332	...	31	483	776	28,517		776	28,517
1880-81	11	307	187	7,120	1,083	52,573	...	187	7,120	1,094	52,880		1,094	52,880
1881-82	3	140	39	797	3,505	1,57,934	...	39	797	3,508	1,58,074		3,508	1,58,074
1882-83	11	600	31	1,897	4,614	2,25,187	...	31	1,897	4,625	2,25,987		4,625	2,25,987
1883-84	20½	1,631	6	280	108	6,890	5,038	2,81,823	...	128½	8,021	5,964	2,82,103		5,964	2,82,103
1884-85	1	60	36	1,453	190	10,482	3,529	1,07,567	...	191	10,542	3,565	1,09,020		3,565	1,09,020
TOTAL	63½	3,360	873	40,782	1,462	80,517	21,987	10,03,972	...	1,525	83,887	22,780	10,44,754		22,780	10,44,754
1885-86	10	650	295	10,611	2,707	1,40,217	...	246	11,261	2,707	1,40,217		2,707	1,40,217
1886-87	5	484	6	180	367	15,147	1,306	66,806	...	372	15,631	1,312	67,000		1,312	67,000
1887-88	385	16,398	45,049	385	16,398	45,049	...		385	45,049
1888-89	1	68	...	57	181	8,082	2,600	1,07,832	...	529	30,558	6,187	1,07,129		6,187	1,07,129
1889-90	38	3,566	56	2,717	481	27,092	6,081	2,60,733	...	529	30,558	6,187	1,07,129		6,187	1,07,129
1890-91	3	231	137	5,366	95	3,556	4,104	1,40,722	...	86	4,067	4,331	1,46,118		4,331	1,46,118
TOTAL	57	5,027	200½	8,300	1,728	85,166	17,904	7,02,263	...	1,785	90,193	18,194	7,70,653		18,194	7,70,653

Table showing Total Export of Timber other than Teak.

YEAR.	TO FOREIGN PORTS.		TO INDIAN PORTS.		TOTAL.	
	RANGOON.	MOUL-MEIN.	RANGOON.	MOUL-MEIN.	RANGOON.	MOUL-MEIN.
	Value in	Value in	Value in	Value in	Value in	Value in
	R	R	R	R	R	R
1880-81	P	220	P	74,088	8,225	74,308
1881-82	6,943	1,264	2,81,925	1,264	2,88,868
1882-83	600	49,447	2,53,355	49,447	2,53,955
1883-84	1,631	280	140,448	3,15,376	1,42,079	3,15,856
1884-85	260	2,215	2,96,073	1,88,684	2,96,333	1,90,899
1885-86	650	4,931	3,55,670	1,90,957	3,56,320	1,95,888
1886-87	23,479	180	3,10,458	1,43,249	3,53,937	1,43,379
1887-88	44,657	...	2,22,241	68,954	2,66,898	68,954
1888-89	42,591	66,936	1,54,971	2,17,949	1,97,562	2,84,885
1889-90	30,602	2,717	2,84,218	2,93,276	3,14,820	2,95,993
1890-91	7,961	50,950	2,31,951	3,00,603	2,39,912	3,51,553
TOTAL	1,51,831	1,35,922	20,46,741	23,28,416	22,06,797	24,64,338

For the last few years small quantities have been exported from the ports of Mergui and Tavoy.

III.—PRESENT STATE OF TEAK TRADE.

The trade in Teak is at present flourishing, and fairly high prices are being realized. At the last auction sale (30th January, 1892) of logs in the round held at the Government Timber Depot at Rangoon the prices obtained were as follows :—

	Length.	Middle girth.	Rate.		
			R	a.	p.
Yard-pieces	45' and above	4' 6" and above	123	0	0
Doogyis	25' to 44'	4' 6" and above	72	8	0
Luzars	18' to 24'	4' 6" and above	70	0	0
Yatthits	18' and above	Under 4' 6"	31	0	0
Rejected split, hollow, crooked or burnt, etc.	30	0	0

These prices are fairly high. At this sale the competition was good, not only among the big timber merchants, but also amongst the smaller ones.

One firm has two large sailing vessels waiting in the river to be loaded for England, where the market is now firm, it having recovered from the shock which it received owing to several consignments of very inferior Teak from Bangkok being sent.

For the present the prices are likely to remain fairly high, as, in consequence of the bad rains last year, the usual amount of timber from Upper Burma could not come down. This means that later on the Bombay-Burma Trading Corporation, Limited will probably have to buy.

There is a very fair trade, I am told, now being done in Mango wood, which is being used for dunnage and also for ventilators on the rice ships.

In conclusion I might compare the rate of freights now and twenty years ago.

Twenty years ago £4-10-0 to £5 per ton and insurance £7-7-0 per cent. was charged, and the time then taken to go to England and elsewhere was very long, as the ships used were, as a rule, rotten old tubs. Now it is about 45s. freight per ton, with insurance 4 per cent. on sailing vessels and only about $\frac{1}{2}$ per cent. on steamboats.

IV.—POSSIBLE DEVELOPMENT OF TIMBER TRADE.

There is a large future before Burma in the timber market in species of wood which at present are little known, and still larger when the present stock in the American forests is exhausted, which it is rapidly becoming. In this country there are innumerable good woods which are seldom used, except in small quantities for domestic purposes by the Burmans themselves. These must in time prove of value, when the timber which is easily got at is exhausted, and when the means of carriage become more easy. Owing to the building of railways and making of roads this great desideratum is yearly advancing.

Among such species I may mention—

(i) *The Pyinkado (Xylia dolabriformis)*.—This wood, the Iron wood of Burma, is already coming into use. It is a very heavy, dark-colored wood, weighing about 65lbs per cubic foot. In Southern India it is largely used for railway sleepers, etc., owing to its great durability. Quite recently it has been used in Burma for the same purpose. A few weeks ago, in fact, the writer was told by the Superintending Engineer for Way and Works of the Burma State Railway that as long as Pyinkado could be got fairly cheap no other timber was wanted for sleepers, though, owing to its hardness, very large numbers of augers are yearly broken. In the Pegu Circle this tree is very plentiful and of large dimensions. In Aracan,

according to Dr. Schlich's report (1860), a third of the forest vegetation consists of this species; and, according to Mr. Nisbet's report (1883), Pyinkado is the tree most plentiful in that province. Of this timber Mr. Laslett in his work entitled "Timber and Timber Trees" says: "The samples I met with all looked remarkably well, and seemed fit to be employed in any work of construction where great strength is required." The great drawback against it is its weight, which makes it very difficult and expensive to put it on the market.

Padauk (Pterocarpus indicus).—Another Burmese wood, which would I fancy come into favour, were it only more pushed, though at present it is becoming known, is Padauk. This again is a heavy close-grained reddish wood, but is not so hard and is therefore much more easily worked than the Pyinkado. Its weight is about 60lbs per cubic foot.

It is prized above all other woods for cart wheels, and is also extensively used for gun-carriages. Brandis says that trees of the largest size abound to the east of the Sittang.

That it is becoming better known in England is shown by (i) C. Leary & Co.'s monthly circular (5th November, 1891), which says there is a steady demand at from R3 to R3-9 per cubic foot; (ii) In the weekly paper "Timber" for December, 1891, the following remarks occur: "Padauk wood is coming into favour in the north of England." "The effect produced by the use of polished Padauk for windows, doors and casings is unique." "After a careful inspection of this beautiful mahogany (*sic*) of Burma, it is difficult even for a connoisseur in fancy woods to forget that he is not looking at the richest and most perfect example of Spanish wood."*

This wood came from the Andamans.

Didók (Bombax insignis).—This is a light-colored wood, weighing about 30lbs per cubic foot. The wood, though much more lasting than that of *B. malabaricum*, is not durable, but, owing to its extreme lightness of weight, it should prove very useful for packing cases of a temporary nature. At the present time it is being extensively used in Burma for packing prepared catch for shipment to England, and would form a very good and light wood for tea boxes, etc. For such purposes it is well worth a more extensive trial, as much would be saved in freight on large shipments; moreover very large and broad boards could be obtained. As it is so light, it is easy to get it to market, and, as it is soft, the working and sawing charges should not be heavy. It has been shipped from the Andamans in the shape of tea boxes.

In. or Eng (Dipterocarpus tuberculatus).—The timber of this tree is a hard red-colored wood, weighing about 52lbs. the cubic foot.

* A detailed account of Padauk wood has been published as an appendix to the "Indian Forester," July, 1892.

It is largely used in Burma for house-building, and lasts about six years in boards exposed to the rains, but is a favourite food of the white ants.

This wood has been used extensively by Cutch merchants for packing Cutch for shipment to England. The Bombay-Burma Trading Corporation, Limited, who do a large trade in Cutch, use this wood almost entirely, and have established a saw-mill up country at which little else than the making of Eng Cutch boxes is done. Owing to the weight of the wood and the amount of oil contained in it, it is not suited for making tea boxes; but whether it has been used for this purpose I cannot say.

Is also used for making ventilators, for which purpose I am told it is an excellent wood.

Thitya (Shorea obtusa); *Inggyin (Shorea Siamensis)*.—These trees are both closely allied to the Sâl tree of India, the timber of which is so well known.

The timber of the *Thitya* is more even-grained than that of the Sâl; it weighs almost 60 lbs per cubic foot. The *Inggyin* weighs about 54 lbs. Both woods are much prized on account of their durability.

Thitkado (Cedrela Toona).—The Toon tree. The wood of this tree is durable and not eaten by white ants. Its average weight is about 37 lbs the cubic foot. It is used for furniture, and has been exported from Burma for making cigar boxes. If not well seasoned it shrinks, which is a great drawback against its use for furniture-making.

Thitka (Pentace burmanica).—An even-grained reddish wood, weighing about 42 lbs the cubic foot; used for tea and cigar boxes.

The two last species have not been able to hold their own against the Cedar and Bastard Mahogany imported from South America, owing to the high price of freight from the Burmese ports.—*Vide Forest Administration Report for British Burma, 1873-74.*

Pyinma (Lagerstrœmia Flos Regina).—A very valuable light red hard wood, weighing about 42 lbs. the cubic foot, which would be very useful for boat-fitting, etc., and is used for ordnance purposes. It is a splendid wood for sleepers and all purposes where the timber is exposed to the damp. It is plentiful throughout British Burma.

Amongst other woods which may turn out to be very useful as the demand arises are—

Gungaw (Mesua ferrea).—A very hard strong imperishable wood, very difficult to work. Not plentiful.

Gyo. (Schleichera trijuga).—Hard, close-grained, and lasting. Fairly common throughout Burma.

Pinlè kanazo. (Heritiera littoralis).—Hard, close-grained and very strong, but difficult to work and seasons slowly. Makes very good gun-stocks. Grows near the sea.

Magyi (Tamarindus indica).—Heart wood very hard, but almost imperishable. Cultivated all over Burma, so small quantities could be available.

Kyithé (Gluta tavoyana).—A dark red handsome wood which takes an excellent polish and seasons and works well. Common in the Andamans.

Thingan (Hopea odorata).—A yellowish hard wood. Is heavy and lasts very well.

Karamé (Cinnamomum ?).—A very good moderately hard wood. Found in Tenasserim, but not in large quantities. A small trade is done in it for house, building. It takes a beautiful polish for furniture. According to Gamble it is also used for shingles.

Anan (Fagraea fragrans).—An invaluable wood for sub-marine works, as it is not attacked by the mollusc *Teredo*. Found in Tenasserim.

Kazan (Hymenodictyon excelsum).—A very light close-grained wood weighing about 33lbs per cubic foot. It is easily worked and straight grained. Would make an excellent wood for packing cases. For this purpose it is, I should say, a better wood than *Didök*, but the tree is neither so large nor so plentiful as the latter.

Kanyin (Dipterocarpus turbinatus, D. alatus, D. levis).—A reddish brown wood weighing about 48lbs per cubic foot. The wood does not last more than a year or two when exposed in a damp climate. Is largely used in Burma for canoes and planking. The trees are plentiful and of a large size. Large quantities are now being exported for tea chests and ventilators of rice cargoes.

An attempt has, I hear, been made lately to supply sleepers of this wood in large quantities to Indian railways. For this purpose, owing to its rapid decay when exposed, it is unsuitable.

FOR SALE, at the Imperial Forest School, Dehra
Dún, the School Calendar for January 1st,
1892, Price As. 8; by V. P. Post As. 12.

Apply to STOREKEEPER.

WE are obliged to remind our subscribers that
we cannot accept contributions which are not
authenticated by the names of their authors (see
cover). We have received some such lately and must
keep them till the authors furnish us with their
names.

HON. ED

TO appear, on or about January 1st, 1893, the Index
to Vols. I to XVII of the 'Indian Forester.'
Price Re. 1. Applications for copies may be made to
the Publishers,

The Mafasilite Printing Works Company, Ltd.,
Mussoorie.

NOTICE.

Contributions should be sent to the Honorary Editor, J. S. GAMBLE, ESQ., *Dehra Dún*. It is requested that all contributions may be written legibly in ink and on one side of the paper only.

The Honorary Editor will not be responsible for the opinions expressed in papers other than Editorial. Contributors are invited to sign their contributions or to affix to them some *monogramme de-plume*. But a signature is preferable, for professional opinions naturally carry greater weight when their author is known, but all contributions must be authenticated by the name and address of the writer being communicated to the Editor.

The Honorary Editor reminds native contributors and especially old Students of *Dehra Dún Forest School*, that under the Rules for the utilization of the Brandis Prize Fund (see Vol. XVI, page 258) good papers are eligible for reward from that fund.

The rates of subscription are as follows, per year.

	In advance.	In arrear.
For Forest Officers whose salary is Rs. 200 per mensem, or less	Rs. 6	Rs. 7-6
For other Subscribers	" 12	" 18
Rates for foreign subscribers per year, in advance,	Rs. 12-6	" 15-6

'Arrear' subscriptions are those paid *after* the 1st April each year.

The Honorary Editor wishes to make it known that the rule regarding 'arrear' rates will be strictly enforced in 1892 and future years, and trusts that subscribers will help him to carry on the Journal properly by paying their subscriptions *punctually* in future. They should be sent to the Publishers.

He desires to urge upon regular subscribers the advantage of their authorizing the Publishers to send the January number for each year regularly by Value Payable Post for the amount of their advance subscription.

Contributors can be supplied with 6 extra copies of their contributions, if two pages or more in length, free of charge. If more copies are wanted, they will be charged for at the rate of 4 as. per page for each 12 copies.

All Correspondence about subscriptions, addresses, etc. should be sent to the Manager, Mafasilite Printing Works Co. Limited, Mussoorie.

The London Agency has been discontinued.

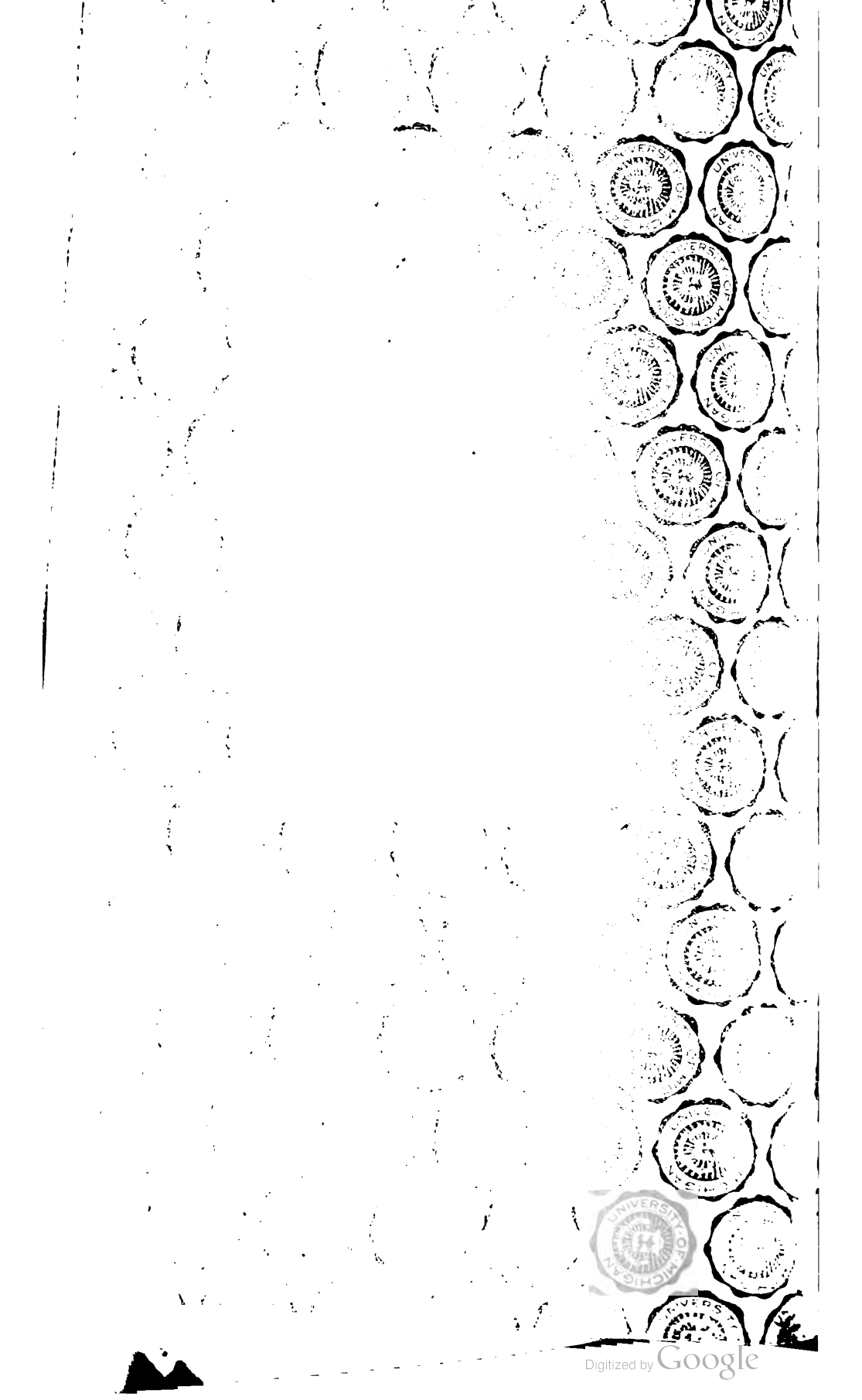

BOUND

JUN 20 1930

UNIVERSITY OF MICHIGAN LIBRARY

UNIVERSITY OF MICHIGAN



3 9015 06860 3797



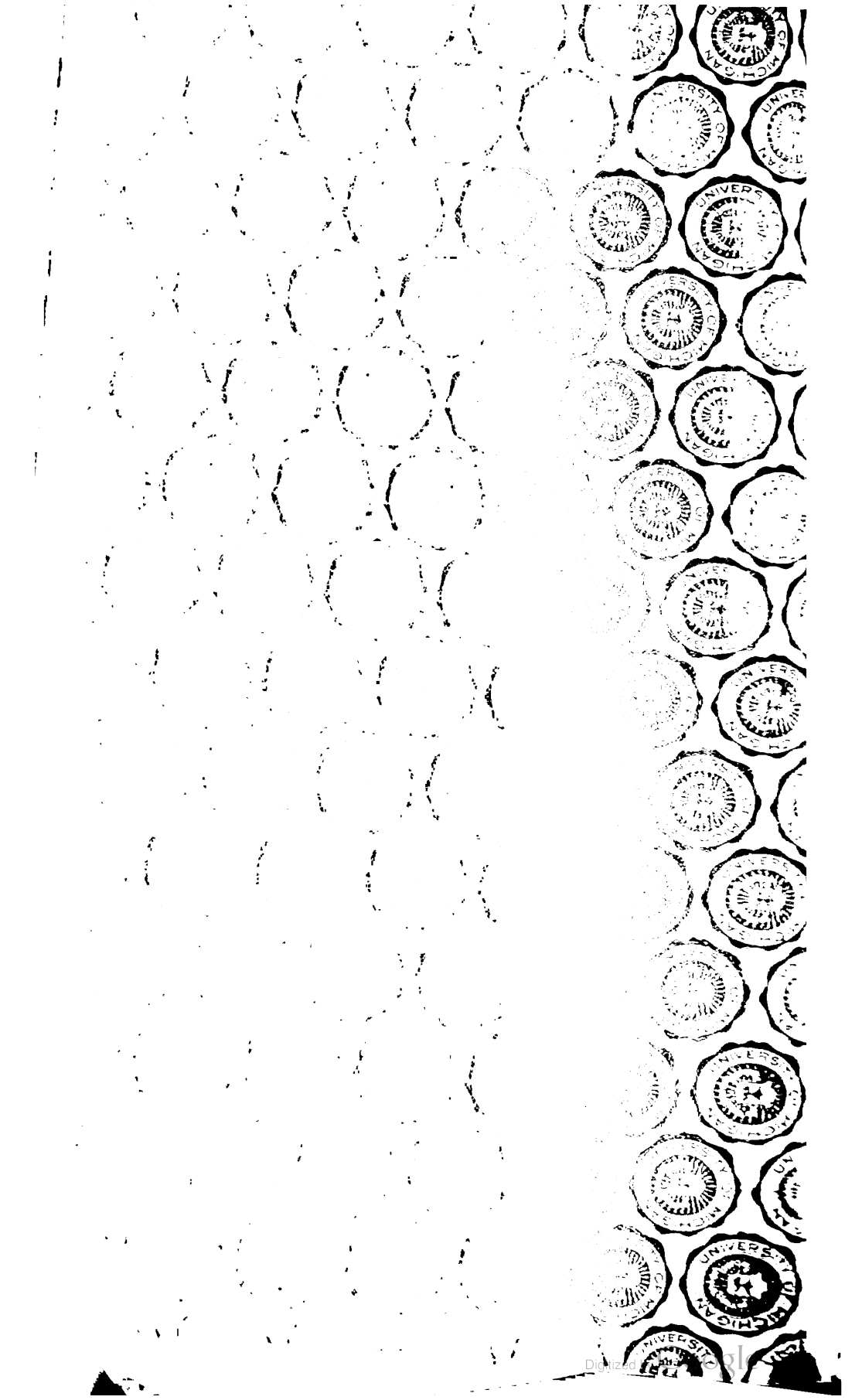

BOUND

JUN 20 1980

UNIVERSITY LIBRARY

UNIVERSITY OF MICHIGAN



3 9015 06860 3797



